

**SRI LANKA STANDARD 557:2017**  
UDC : 667.633.22

**SPECIFICATION FOR  
EMULSION PAINTS FOR EXTERIOR USE  
(SECOND REVISION)**

**SRI LANKA STANDARDS INSTITUTION**



**Sri Lanka Standard**  
**SPECIFICATION FOR EMULSION PAINTS FOR EXTERIOR USE**  
**(Second Revision)**

**SLS 557:2017**  
**(Attached AMD 558)**

**Gr. 7**

*Copyright Reserved*  
**SRI LANKA STANDARDS INSTITUTION**  
**17, Victoria Place,**  
**Elvitigala Mawatha,**  
**Colombo 8,**  
Sri Lanka.

Sri Lanka Standards are subject to periodical revision in order to accommodate the progress made by industry. Suggestions for improvement will be recorded and brought to the notice of the Committees to which the revisions are entrusted.

This standard does not purport to include all the necessary provisions of a contract.

© SLSI 2017

All right reserved. Unless otherwise specified, no part of this publication may be reproduced or utilized in any form or by any means, electronic or mechanical, including photocopying and microfilm, without permission in writing from the SLSI.

**Sri Lanka Standard**  
**SPECIFICATION FOR EMULSION PAINTS FOR EXTERIOR USE**  
**(Second Revision)**

## **FOREWORD**

This Sri Lanka Standard was approved by the Sectoral Committee on Chemical and Polymer Technology and was authorized for adoption and publication as a Sri Lanka Standard by the Council of the Sri Lanka Standards Institution on 2017-05-04.

Emulsion paints have gained popularity for characteristics such as ease of application, quick drying properties, non-objectionable odour and good washability. In these paints water is used for thinning instead of organic solvents. As far as emulsion paints for exterior use are concerned, weathering resistance is the one of the most important criterion.

This Standard was first published in 1982 and First Revision was issued in 2009. This Second Revision is issued to incorporate amendments brought to **SLS 557:2009** and to introduce new Test Method for determination of drying time and resistance to alkali. In this revision the test panels of asbestos have been replaced by non asbestos panel and changed the pH and number of cycles for determination of scrub resistance. Accelerated method have been introduced for determination of resistance to fungus.

This Standard is subject to the restrictions imposed under the Consumer Affairs authority Act No. 09 of 2003 and any other relevant Acts.

For the purpose of deciding whether a particular requirement of this Specification is complied with, the final value, observed or calculated, expressing the result of a test or an analysis, shall be rounded off in accordance with **SLS 102**. The number of significant places retained in the rounded off value shall be the same as that of the specified value in this Specification.

## **1 SCOPE**

This Specification prescribes the requirements and methods of sampling and tests for emulsion paints used for exterior decoration on buildings after surface preparation and priming wherever necessary.

## **2 REFERENCES**

ASTM D	1308	Standard Test Method for Effect of Household Chemicals on Clear and Pigmented Organic Finishes
ASTM D	2486	Standard Test Methods for Scrub Resistance of Wall Paints
ASTM D	5590	Standard Test Method for Determining the Resistance of Paint Films Related Coatings to Fungal Defacement by Accelerated Four-Week Agar Plate Assay
ASTM D	5895	Standard Test Methods for Evaluating Drying or Curing During Film Formation of Organic Coatings Using Mechanical Recorders

SLS	102	Rules for rounding off numerical values
SLS	489	Glossary of terms for paints
SLS	523	Methods of sampling of paints, varnishes and raw materials for paint and varnishes
SLS	1256	Methods of test for paints and varnishes Part 3 Determination of viscosity at a high rate of shear Part 6 Determination of quantity of material in a container Part 11 Standard panels for testing Part 13 Determination of hard drying time Part 25 Guidance on the conduct of natural weathering tests Part 28 Exposure to laboratory light sources Section 1 General guidance and Section 3 Fluorescent UV lamps Part 30 Determination of surface drying time ballotini method
SLS	ASTM D 3335	Standard Test Method for Low Concentrations of Lead, Cadmium and Cobalt in Paint by Atomic Absorption Spectrometry

### **3 DEFINITIONS**

For the purpose of this Specification, the definitions given in **SLS 489** shall apply.

### **4 REQUIREMENTS**

#### **4.1 Composition**

The material shall be a medium consisting of any stable synthetic polymer emulsion in water containing pigments and applicable additives to produce a material so as to satisfy the requirements of this Specification.

#### **4.2 Conditions of the material in the container**

The material shall be free from lumps, loose skins, extraneous matter and colour separation. If any settlement is observed, the paint shall be capable of being readily re dispersed with a spatula to a smooth homogeneous state. The material shall not have irritating or offensive odour.

#### **4.3 Thinning**

The paint shall mix readily with a minimum amount of foaming to a smooth and homogeneous state when thinned with water as per manufacturer's instructions. Foaming if any, shall dissipate rapidly.

#### **4.4 Application properties**

The material after thinning shall be suitable for application by brush, spray, roller or any other method specified by the manufacturer. The resulting film shall have uniform leveling characteristics and shall not show pigment flocculation and coarseness or other undesirable characteristics.

#### 4.5 Recoating properties

There shall be no lifting of the underlying coats when the paint is thinned with water as per manufacturer's instructions and three successive coats of the material are applied at 50 °C on a non asbestos flat cement sheet at an interval of 30 minutes between successive coatings. The paint film coatings shall not exhibit colour change, sagging, cracking or flaking after application.

#### 4.6 Keeping properties (Before open the container)

The paint when stored under normal storage and temperature condition in the original sealed container shall retain the properties as prescribed in Clause 4 requirements for the specified period which is not less than 1 year. The material shall also be free from any extraneous matter such as fungal and bacterial growth and non objectionable odour.

#### 4.7 Quantity of material

The volume of the material shall be tested as prescribed in **SLS 1256: Part 6** at  $27 \pm 2$  °C. The measured volume shall be within a tolerance of  $\pm 5$  per cent and  $\pm 2$  per cent from the declared volume for the containers up to 5 litre and above 5 litre respectively.

#### 4.8 Colour

The colour of the product shall match with the Standard colour or any reference colour as agreed to between the purchaser and the manufacturer when tested as prescribed in Appendix B.

#### 4.9 Spreading capacity

The spreading capacity shall be determined as prescribed in Appendix C. The minimum spreading capacity shall be 14 m<sup>2</sup>/litre. Volume of the material applied shall be determined as in 4.7.

#### 4.10 Resistance to artificial weathering

When the paint film is prepared and tested in accordance with the methods given in **SLS 1256: Part 28: Section 1** and **SLS 1256: Part 28: Section 3** there shall be no considerable change in colour, loss of gloss, blistering and cracking of the paint film.

#### 4.11 Resistance to alkali

The coating shall not show cracking, peeling, wrinkling, chalking and other visual defects when tested and examined as prescribed in Method 1 of Appendix D. The material shall be deemed to have complied with this requirement when tested and examined as prescribed in Method 2 of Appendix D.

#### 4.12 Resistance to fungal and algal growth

The coated panels shall be free from surface fungal and algal growth when tested as both methods prescribed in Appendix E.

#### 4.13 Lead content

The total lead content of the paint material shall be less than 90 mg/kg when tested as prescribed in SLS ASTM D 3335.

#### 4.14 Other requirements

The material shall also comply with the requirements given in Table 1 when tested in accordance with the methods given in Column (4) of the table.

**TABLE 1 – Other requirements for emulsion paints for exterior use**

Sl. No.	Characteristic	Requirement	Method of test
(1)	(2)	(3)	(4)
i)	Drying time, max. a) Surface dry, minutes b) Hard dry, h	15 2	Appendix F
ii)	Viscosity at 25 ±2 °C Pa s, min.	0.4	SLS 1256: Part 3
iii)	Finish	Smooth and matt or gloss	Appendix F
iv)	pH value, at 27 ±2 °C	8 to 10	Appendix G
v)	Scrub resistance	800 cycles (matt) 1500 cycles (gloss and semi gloss)	ASTM D 2486 (Method A)
vi)	Temperature stability	To pass the test	Appendix H

## 5 PACKAGING AND MARKING

### 5.1 Packaging

The material shall be packed in sound, clean, dry, leakage-free and corrosion-resistant containers. The volume of the material shall be as agreed to between the manufacturer and the purchaser.

### 5.2 Marking

Each container shall be marked legibly and indelibly with the following:

- a) Type of the product as “Emulsion paint for exterior use”;



- b) Colour;
- c) Name and address of the manufacturer including the country of origin;  
(**NOTE** *Name and address of the manufacturer and the distributor need to be marked on imported products.*)
- d) Brand name if any;
- e) Net volume of the material, in litre;
- f) Date of manufacture;
- g) Shelf life / best before;
- h) Batch number or code number or lot identification number;  
(**NOTE:** *if one batch is manufactured during the day date of manufacture may be used as the batch no. /lot identification no. / code no.*)
- j) Spreading capacity, in m<sup>2</sup>/litre;
- k) Registered trade mark if any;
- l) Declared lead content;  
(**NOTE:** *If marked as "lead free", it shall be based on the test results of each batch.*)
- m) Instructions for use;
- n) Special precautions to be obtained in use, if required; and
- o) Specific warning statement(s), where necessary.

## 6 METHOD OF TEST

**6.1** Tests shall be carried out as prescribed in classes **4.5, 4.6** Appendices **B to H, ASTM D 1308, ASTM D 2486, ASTM D 5590, ASTM D 5895, SLS ASTM D 3335** and the relevant sections of **SLS 1256**.

**6.2** During the analysis, unless otherwise stated, use only reagents of analytical grade and only distilled water or water of equivalent purity.

## 7 SAMPLING

Representative samples of the product for ascertaining conformity to the requirements of this specification shall be drawn as prescribed in Appendix **A**.

## **APPENDIX A COMPLIANCE OF A LOT**

The sampling scheme given in this Appendix shall apply where compliance of a lot to the requirements of this Specification has to be assessed based on statistical sampling and inspection.

Where compliance with this Specification, appropriate schemes of sampling and inspection shall be adopted based on manufacturer's control systems coupled with type tests and testing procedures.

### **A.1 LOT**

In any consignment, all the containers of the same size containing paint material of one batch of manufacture shall constitute a lot.

### **A.2 SAMPLING**

The method of drawing representative samples of the material shall be as specified in the relevant clauses of **SLS 523**.

### **A.3 NUMBER OF TESTS**

**A.3.1** Each container selected as in **A.2** shall be inspected for packaging (**5.1**) and marking (**5.2**) requirements.

**A.3.2** From each of the sample containers prepared as in clause **5.2** of **SLS 523**, a small but equal quantity of material shall be taken and mixed thoroughly to form a composite sample. The composite sample shall be transferred to another sample container.

**A.3.3** The remaining portion of material from each sample container shall constitute an individual sample representing a particular container in the lot.

**A.3.4** Tests for requirements given in **4.1** to **4.7** shall be carried out on each individual sample.

**A.3.5** Tests for requirements given in **4.8** to **4.14** shall be carried out on the composite sample.

### **A.4 CRITERIA FOR CONFORMITY**

The material shall be taken as conformed to the Specifications if the following conditions are satisfied:

**A.4.1** Each container inspected as in **A.3.1** satisfies the packaging and marking requirements.

**A.4.2** Each individual sample shall satisfy the relevant requirements tested as in **A.3.4**.

**A.4.3** The composite sample shall satisfy the relevant requirements tested as in **A.3.5**.

## **APPENDIX B DETERMINATION OF COLOUR**

### **B.1 PRINCIPLE**

The colour of the material applied on a white unglazed art paper is compared visually in diffused daylight with that of the standard or agreed colour as appearing on the colour card provided by the relevant manufacturer.

### **B.2 PROCEDURE**

**B.2.1** Apply the material using a film applicator as specified in **SLS 1256 Part 11 : Section 2** to give a wet film thickness of 50 µm on a 150-mm x 150-mm white unglazed art paper. Air-dry the film for 4 hours in a well ventilated room in a horizontal position. During drying protect the film from direct sunlight. When the film is dry, apply a second coat of the material to give again a combined wet film thickness of 50 µm and air-dry. After 24 hours, compare the colour of the film with that of the standard or previously agreed colour visually in diffused daylight.

**B.2.2** The material shall be deemed to have passed the test if the colour of the material matches with the colour card provided by the relevant manufacturer.

## **APPENDIX C DETERMINATION OF SPREADING CAPACITY**

### **C.1 PROCEDURE**

Weigh an appropriate quantity of the material with a suitable brush. The material shall then be applied by brushing to a flat, smooth and non-absorbent surface one square metre in area in a uniform normal coat commensurate with satisfactory coverage and appearance. The balance of the material with the brush shall be weighed.

Volume of the material applied shall be determined as in **4.7**.

The spreading rate shall be calculated as the number of square metres that can be covered by one litre of the paint.

The spreading capacity is given as the average spreading rate.

## **APPENDIX D DETERMINATION OF RESISTANCE TO ALKALI**

Two methods have been prescribed for the determination of resistance to alkali. The method prescribed in **D.1** shall be the reference method and shall be carried out in case of any dispute.

### **D.1 METHOD 1**

**D.1.1** This test shall be carried out as prescribed in **ASTM D 1308**.

### **D.2 METHOD 2 (LIME BURNING TEST)**

#### **D.2.1 Principle**

The material is applied to non asbestos cement panel and the bleaching effect examined. In order to give a basis for comparison, one half of the panel is sealed with alkali resistant solvent based primer.

#### **D.2.2 Materials**

**D.2.2.1** Non asbestos cement panel, 300-mm x 100-mm size flat sheet and having a pH not less than 10

**D.2.2.2** Phthalocyanine blue pigment paste, prepared using phthalocyanine pigment

#### **D.2.3 Procedure**

**D.2.3.1** Select a 300-mm x 100-mm non asbestos cement panel having a pH of not less than 10 and condition it at  $27 \pm 2$  °C for one hour. Seal one half of the same with one coat of an alkali-resistant solvent-based primer, by brushing. Apply the material with a 400-µm film applicator as specified in **SLS 1256 : Part 11: Section 2** to the entire panel. If the material is not coloured, it should be tinted to a light blue shade using suitable phthalocyanine pigment paste, before application. Leave coating until dry and when dry examine the panel for difference in colour between the sealed and the unsealed halves.

**D.2.3.2** The material shall be deemed to have passed the test if the colour difference between the unsealed and the sealed halves is not appreciable when examined visually.

**APPENDIX E**  
**DETERMINATION OF RESISTANCE TO FUNGAL AND ALGAL GROWTH**

**E.1 METHOD 1- RESISTANCE TO FUNGAL AND ALGAL GROWTH**

**E.1.1 Principle**

A flat non asbestos cement panel is evenly coated with two coats of the material by brushing and then air dried for a specified period. The panel is exposed on an exposure rack for a specified period and the intensity of fungal growth is observed.

**E.1.2 Apparatus**

**E.1.2.1 Exposure rack**

The exposure rack shall be constructed as specified in **SLS 1256: Part 25** to support the panel vertically and facing toward the equator.

**E.1.3 Procedure**

Apply two coats of the paint by brushing as specified in **SLS 1256 : Part 11 : Section 2** on a 300-mm x 150-mm x 4-mm clean, dry, untreated flat non asbestos cement panel (see **D.2.2.1**) at an interval 30 minutes drying between coats. The edges and back of the panels shall be coated with a protective paint. Expose the panels on the exposure rack and examine the fungal and algae growth on the panels monthly, for six months.

**E.2 METHOD 2- RESISTANCE TO FUNGAL GROWTH**

**E.2.1** This test shall be carried out as prescribed in **ASTM D 5590**.

**APPENDIX F**  
**DETERMINATION OF DRYING TIME AND APPEARANCE OF DRIED FILM**  
**(FINISH)**

Two methods have been prescribed for each of the determination for surface drying and hard drying times. The method prescribed in **F.1** shall be the reference method and shall be carried out in case of any dispute.

**F.1 METHOD 1**

**F.1.1 Determination of surface drying time (Ballotini method)**

This test shall be carried out as prescribed in **SLS 1256: Part 30**.

### **F.1.2 Determination of hard drying time**

This test shall be carried out as prescribed in **SLS 1256: Part 13**.

## **F.2 METHOD 2**

**F.2.1** Surface drying time and hard drying time shall be determined as prescribed in **ASTM D 5895**.

### **F.3 APPEARANCE OF DRIED FILM (FINISH)**

The second coat of the material shall be applied satisfactorily at the end of 4 hours of the first coating. Examine the panel for surface dry and hard dry after 15 minutes and 2 hours respectively. The material shall be deemed to have complied with the requirement of this standard for finish if the composite film gives a smooth and matt or gloss finish.

## **APPENDIX G DETERMINATION OF pH**

### **G.1 PRINCIPLE**

The material is mixed with freshly boiled water to remove the Carbon dioxide and the Hydrogen ion concentration is measured using a calibrated pH meter.

### **G.2 PROCEDURE**

Weigh  $5.00 \pm 0.01$  g of the material. Place it in a 150-ml beaker and add 50 g of freshly boiled, distilled water. Mix well by means of a glass rod and cool to  $27 \pm 2$  °C. Measure the pH with a pH meter using glass electrodes.

## **APPENDIX H DETERMINATION OF TEMPERATURE STABILITY**

### **H.1 PRINCIPLE**

The material is subjected to extremes of temperature and then tested for thinning and application properties.

### **H.2 PROCEDURE**

**H.2.1** Fill two clean, dry 500-ml metal containers with the material leaving the usual ullage and seal tightly. Keep one of the containers at  $10 \pm 1$  °C and the other at  $60 \pm 2$  °C for 48

hours. Keep these two containers at room temperature for 24 hours thereafter. Subsequently, examine the material in the two containers.

**H.2.2** The material shall be deemed to have passed this test if it is free from lumps, skins, settling and is capable of thinning suitably for application method specified by manufacturer.

.....

**AMENDMENT NO: 01 TO SLS 557: 2017**

**SRI LANKA STANDARD SPECIFICATION FOR EMULSION PAINTS FOR  
EXTERIOR USE (Second Revision)**

**EXPLANATORY NOTE**

The test method for the determination of resistance to wet abrasion has been revised to overcome the practical difficulties encountered with the previous test method. The requirement also has been changed to be in line with the proposed test method.



**Amendment No: 01 approved on 2022-02-21 to SLS 557: 2017**

**SRI LANKA STANDARD SPECIFICATION FOR EMULSION PAINTS FOR EXTERIOR USE (Second Revision)**

**2 REFERENCES**

Delete “ASTM D 2486 Standard Test Methods for Scrub Resistance of Wall Paints”

Insert the following after SLS 523 Methods of sampling of paints, varnishes and raw materials for paint and varnishes

“SLS 554 Laundry soap”

**4 REQUIREMENTS**

**TABLE 1 : Other requirements for emulsion paints for exterior use**

Delete the S. No. v) given in Table 1 and substitute the following:

<b>“Sl. No (1)</b>	<b>Characteristic (2)</b>	<b>Requirement (3)</b>	<b>Method of test (4)</b>
v)	Resistance to wet abrasion	To pass the test	Appendix J”

**6 METHOD OF TEST**

Delete the letter “H” and substitute the letter “J” given in Clause 6.1.

Delete the “ASTM D 2486” given in Clause 6.1.

Insert the following Appendix J at the end of Appendix H.

**“APPENDIX J  
DETERMINATION OF RESISTANCE TO WET ABRASION**

**J.1 PRINCIPLE**

The painted panels are subjected to wet rubbing in the abrasion test apparatus at a specified speed and load of the brush. The panels are examined at the end of the stipulated oscillations for film defects.

**J.2 APPARATUS**

**J.2.1** Wet abrasion tester, as shown in Figure 1 and having the following accessories:

- a) Washing unit, of such a construction as to hold the brush in a box or holder which moves backwards and forwards in a straight line across the test panels at the rate of  $38 \pm 2$  strokes per minute. The trays shall be watertight to hold the panels.
- b) Brush, a pad made out of polyurethane foam of density  $25 \text{ kg/m}^3$  and of size  $85 \text{ mm} \times 36 \text{ mm} \times 12 \text{ mm}$ . The total mass of the brush and the holder shall be  $500 \text{ g}$ .
- c) Fractional horse power motor, of suitable speed to regulate the oscillations of the brush.

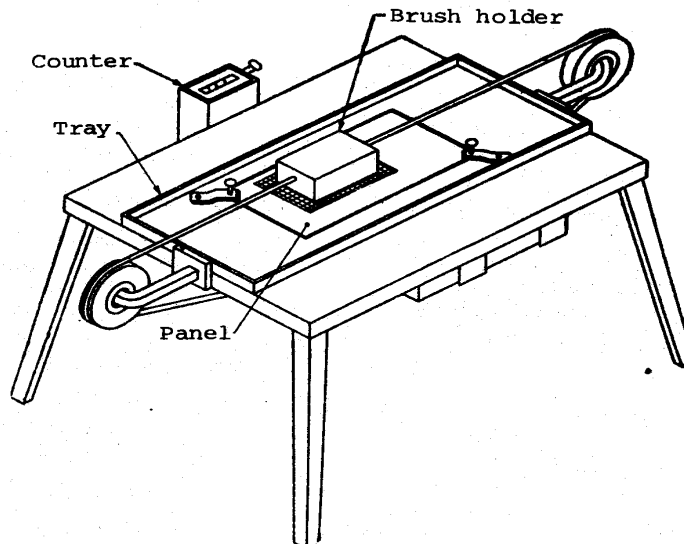

**FIGURE 1 - Wet abrasion tester**

### J.3 REAGENTS

#### J.3.1 Soap solution

Dissolve 0.5 g of laundry soap (conforming to **SLS 554**) weighed to the nearest 0.01 g (previously dried at  $105 \pm 2$  °C for 30 minutes) in distilled water to give 0.5 per cent (m/v) solution.

### J.4 PROCEDURE

#### J.4.1 Preparation of the panel

Clean a glass panel, 415 mm x 120 mm in size conforming to **SLS 1256: Part 11: Section 1**. Apply a coat of the undercoating enamel using a film applicator as specified in **SLS 1256: Part 11: Section 2** to give a wet film thickness of 35 µm to 38 µm and store at 120 °C for 30 minutes. Rub down with an emery paper and wipe until the gloss is removed completely. Apply a coat of the material by applying over the dried undercoat to give a wet film thickness of 150 µm. Allow this to air dry for 168 hours.

**J.4.2** Dip the brush in distilled water at  $25 \pm 2$  °C for 30 minutes, to a depth of 12 mm. Shake off excess water and soak in the soap solution for 5 minutes. Fix the painted test panel in the tray in position with painted surface upwards. Fix the brush in its holder having a total load of 0.5 kg and adjust the stroke in such a way that not less than 10 mm of the film is left free on both ends. Start the oscillations of the brush. Keep the panel wet by adding soap solution at the rate of 10 to 12 drops per minute in the path of the brush. At the end of 4 000 oscillations remove the panel. Wash with water, allow to dry and examine the film for any defects.

**J.4.3** The material shall be deemed to have passed the test if the material does not show film defects like blistering, exposure of undercoat and colour fading”.

.....



## **SLS CERTIFICATION MARK**

*The Sri Lanka Standards Institution is the owner of the registered certification mark shown below. Beneath the mark, the number of the Sri Lanka Standard relevant to the product is indicated. This mark may be used only by those who have obtained permits under the SLS certification marks scheme. The presence of this mark on or in relation to a product conveys the assurance that they have been produced to comply with the requirements of the relevant Sri Lanka Standard under a well designed system of quality control inspection and testing operated by the manufacturer and supervised by the SLSI which includes surveillance inspection of the factory, testing of both factory and market samples.*

*Further particulars of the terms and conditions of the permit may be obtained from the Sri Lanka Standards Institution, 17, Victoria Place, Elvitigala Mawatha, Colombo 08.*



## SRI LANKA STANDARDS INSTITUTION

The Sri Lanka Standards Institution (SLSI) is the National Standards Organization of Sri Lanka established under the Sri Lanka Standards Institution Act No. 6 of 1984 which repealed and replaced the Bureau of Ceylon Standards Act No. 38 of 1964. The Institution functions under the Ministry of Science, Technology and Research.

The Principal objects of the Institution as set out in the Act are to prepare standards and promote their adoption, to provide facilities for examination and testing of products, to operate a Certification Marks Scheme, to certify the quality of products meant for local consumption or exports and to promote Standardization and quality control by educational, consultancy and research and research activity.

The Institution is financed by Government grants, and by the income from the sale of its publications and other services offered for Industry and Business Sector. Financial and Administrative control is vested in a Council appointed in accordance with the provisions of the Act.

The development and formulation of National Standards is carried out by Technical Experts and representatives of other interest groups, assisted by the permanent officers of the Institution. These Technical Committees are appointed under the purview of the Sectoral Committees which in return are appointed by the Council. The Sectoral Committees give the final Technical approval for the Draft National Standards prior to the approval by the Council of the SLSI.

All members of the Technical and Sectoral Committees render their services in an honorary capacity. In this process the Institution Endeavours to ensure adequate representation of all view points.

In the International field the Institution represents Sri Lanka in the International Organization for Standardization (ISO), and participates in such fields of Standardization as are of special interest to Sri Lanka.