

SRI LANKA STANDARD 938 : PART 4 : 1991

UDC 621.882.4

SPECIFICATION FOR

PLAIN METAL WASHERS

PART 4 - CHAMFERED - NORMAL SERIES - PRODUCT GRADE A

SRI LANKA STANDARDS INSTITUTION

- Blank Page -

SPECIFICATION FOR PLAIN METAL WASHERS
PART 4 ; CHAMFERED - NORMAL SERIES - PRODUCT GRADE A

SLS 938:Part 4:1991

Gr. 4

Copyright Reserved

SRI LANKA STANDARDS INSTITUTION
53, Dharmapala Mawatha,
Colombo 3,
Sri Lanka.

Sri Lanka Standards are subject to periodical revision in order to accommodate the progress made by industry. Suggestions for improvement will be recorded and brought to the notice of the Committees to which the revisions are entrusted.

This standard does not purport to include all the necessary provisions of a contract.

SRI LANKA STANDARD
SPECIFICATION FOR PLAIN METAL WASHERS
PART 4 : CHAMFERED - NORMAL SERIES - PRODUCT GRADE A

FOREWORD

This standard was authorized for adoption and publication as a Sri Lanka Standard by the Council of the Sri Lanka Standards Institution on 91-10-29, after it had been approved by the Mechanical Engineering Divisional Committee.

This standard consisting of the following parts supersedes SLS 238 : 1973 :

Specification for Plain Metal Washers

- Part 1 Small series - Product Grade A
- Part 2 Normal series - Product Grade A
- Part 3 Normal series - Product Grade C
- Part 4 Chamfered - Normal series - Product Grade A
- Part 5 Large series - Product Grades A and C
- Part 6 Extra Large series - Product Grade C
- Part 7 Sampling

For the purpose of deciding whether a particular requirement of this Standard is complied with, the final value, observed or calculated, expressing the result of a test or an observation shall be rounded off in accordance with CS 102. The number of figures to be retained in the rounded off value shall be the same as that of the specified value in this standard.

The Sri Lanka Standards Institution gratefully acknowledges the use of relevant publications of the International Organization for Standardization in the preparation of this standard.

1 SCOPE

This part of the standard lays down class, designation, material dimensions, marking and sampling for chamfered - small series Product grade A.

2 REFERENCES

- ISO 272 Fastners - Hexagon products - width across Flats
- ISO 887 Plain washers for metric bolts, screws and nuts - General plan.
- ISO 1456 Metallic Coatings - Electroplated coatings of nickel plus chromium
- ISO 1457 Metallic Coatings - Electroplated coatings of copper plus nickel plus chromium on iron or steel
- ISO 1458 Metallic coatings - Electroplated coatings of nickel
- ISO 4759 Tolerances for fastners -
Part 3 Washers for metric bolts, screws and nuts with thread diameters from 1 up to and including 150 mm - Product grades A and C
- CS 102 Presentation of numerical values
- SLS 482 Code of practice for hot dip galavanizing of iron and steel
- SLS* Plain metal washers
Part 7 Sampling

3 DEFINITIONS

For the purpose of this standard the following definitons shall apply.

3.1 Grade : The degree of preciseness of the clearance hole. There are two grades, namely, product A and Product C. Product A being more precise as specified in ISO 887 and ISO 4759 : Part 3.

3.2 Type : Comparative size of the outer diameter. Types are small series (SS), normal series (NS), large series (LS) and extra series (ELS).

3.3 Class : A measure of the Vickers hardness number and an indication of the material. A washer made of steel of Vickers hardness 140 HV is of class 140 HV and if a washer is made of austenitic stainless steel of Vickers hardness 140 HV, the class is AS 140 HV.

4 GRADE, TYPE, CLASS AND DESIGNATION

4.1 Grade

The grade of metal washers shall be Product grade A.

* *Under preparation*

TABLE 1 - Dimensions of metal washers

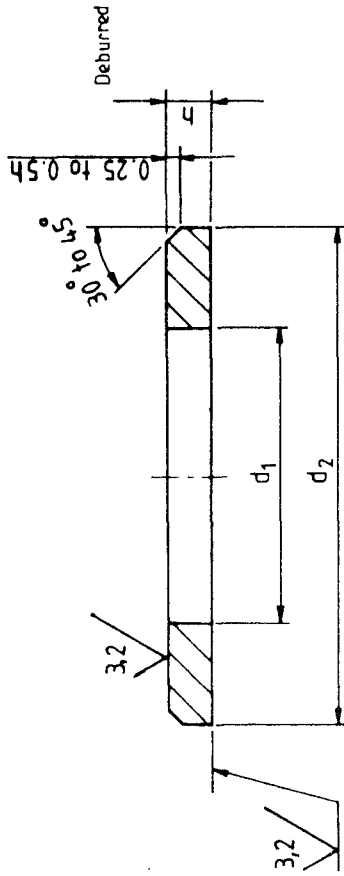

Dimensions in millimetres

Nominal size (thread size, d) (1)	Clearance hole d ₁		Outside diameter d ₂		Thickness h		
	nom. (min.) (2)	max. (3)	nom. (max.) (4)	min. (5)	nom. (6)	max. (7)	min. (8)
5	5.3	5.48	10	9.64	1	1.1	0.9
6	6.4	6.62	12	11.57	1.6	1.8	1.4
8	8.4	8.62	16	15.57	1.6	1.8	1.4
10	10.5	10.77	20	19.48	2	2.2	1.8
12	13	13.27	24	23.48	2.5	2.7	2.3
14	15	15.27	28	27.48	2.5	2.7	2.3
16	17	17.27	30	29.48	3	3.3	2.7
20	21	21.33	37	36.38	3	3.3	2.7
24	25	25.33	44	43.38	4	4.3	3.7
30	31	31.39	56	55.26	4	4.3	3.7
36	37	37.62	66	64.8	5	5.6	4.4

4.2 Type

The type of metal washers shall be chamfered - normal series.

4.3 Designation

Washers shall be designated by grade type, nominal hole diameter, material and Vickers hardness.

EXAMPLES

- 1) A NS 8 - 140 HV - Chamfered.
A refers to Product grade A.
NS refers to normal series.
8 refers to hole diameter, d, in mm, and
140 HV refers to steel of 140 HV.
- 2) A NS 8 - As 140 HV - Chamfered.
AS 140 HV refers to Austenitic stainless steel having
hardness 140 HV.

5 REQUIREMENTS

5.1 Material

Material for Product A, washers shall be either steel or austenitic stainless steel having the following hardness values.

- a) Steel 140 HV, 200 HV, 300 HV
- b) Austenitic Stainless Steel 140 HV, 200 HV, 350 HV

5.2 Dimensions

Dimensions of metal washers shall be as given in Table 1.

6 MARKING

The package of washers shall be marked legibly and indelibly with the following informations.

- a) Designation :
- b) Quantity, either as number of washers or as net weight; and
- c) Name of Manufacturer or Registered Trade Mark.

7 SAMPLING

Sampling and conformity to standard shall be as given in SLS.... Part 7

SRI LANKA STANDARDS INSTITUTION

The Sri Lanka Standards Institution (SLSI) is the National Standards Organization of Sri Lanka established under the Sri Lanka Standards Institution Act No. 6 of 1984 which repealed and replaced the Bureau of Ceylon Standards Act No. 38 of 1964. The Institution functions under the Ministry of Science & Technology.

The principal objects of the Institution as set out in the Act are to prepare standards and promote their adoption, to provide facilities for examination and testing of products, to operate a Certification Marks Scheme, to certify the quality of products meant for local consumption or exports and to promote standardization and quality control by educational, consultancy and research activity.

The Institution is financed by Government grants, and by the income from the sale of its publications and other services offered for Industry and Business Sector. Financial and administrative control is vested in a Council appointed in accordance with the provisions of the Act.

The development and formulation of National Standards is carried out by Technical Experts and representatives of other interest groups, assisted by the permanent officers of the Institution. These Technical Committees are appointed under the purview of the Sectoral Committees which in turn are appointed by the Council. The Sectoral Committees give the final Technical approval for the Draft National Standards prior to the approval by the Council of the SLSI.

All members of the Technical and Sectoral Committees render their services in an honorary capacity. In this process the Institution endeavours to ensure adequate representation of all view points.

In the International field the Institution represents Sri Lanka in the International Organization for Standardization (ISO), and participates in such fields of standardization as are of special interest to Sri Lanka.

SLS CERTIFICATION MARK

The Sri Lanka Standards Institution is the owner of the registered certification mark shown below. Beneath the mark, the number of the Sri Lanka Standard relevant to the product is indicated. This mark may be used only by those who have obtained permits under the SLS certification marks scheme. The presence of this mark on or in relation to a product conveys the assurance that they have been produced to comply with the requirements of the relevant Sri Lanka Standard under a well designed system of quality control inspection and testing operated by the manufacturer and supervised by the SLSI which includes surveillance inspection of the factory, testing of both factory and market samples.

Further particulars of the terms and conditions of the permit may be obtained from the Sri Lanka Standards Institution, 17, Victoria Place, Elvitigala Mawatha, Colombo 08.

