

SRI LANKA STANDARD 373:1976  
UDC; 629.118.3.011

**SPECIFICATION FOR  
BICYCLE BRAKE  
SHOE ASSEMBLIES**

**BUREAU OF CEYLON STANDARDS**



SPECIFICATION FOR  
BICYCLE BRAKE SHOE ASSEMBLIES

SLS 373:1976

Gr. 4

~~XXXXXXXXXX~~

*Copyright Reserved*

BUREAU OF CEYLON STANDARDS  
53, Dharmapala Mawatha,  
Colombo 3,  
Sri Lanka.

*Sri Lanka Standards are subject to periodical revision in order to accommodate the progress made by industry. Suggestions for improvement will be recorded and brought to the notice of the Committees to which the revisions are entrusted.*

*This Standard does not purport to include all the necessary provisions of a contract.*

SRI LANKA STANDARD  
SPECIFICATION FOR  
BICYCLE BRAKE SHOE ASSEMBLIES

FOREWORD

This Sri Lanka Standard Specification has been prepared by the drafting committee of the Bureau on Bicycle Brake Shoe Assemblies. It was approved by the Mechanical Engineering Divisional Committee of the Bureau of Ceylon Standards and was authorised for adoption and publication by the Council of the Bureau on 1976-01-07.

This standard is one of the series of Sri Lanka Standards on bicycle components.

The bicycle brake shoe assembly covered in this specification are intended for fitting on the brake arches of standard sizes of bicycles having lever type brakes that are in common use. Washers of two types, namely, plain and spring have been included. Brake shoe assemblies for caliper type brakes are not covered in this specification. The screw threads adopted are the ISO (International Organization for Standardization) Metric Screw

Threads covered in SLS 268 ISO Metric screw threads  
(Parts 1 to 6).

All quantities and dimensions in this specification has been given in SI units together with the corresponding metric value within brackets where ever relevant.

Abrasion qualities and wear resistance in wet and dry conditions are important parameters of brake blocks and tests on these features will be introduced in due course.

This standard requires reference to the following Sri Lanka Standards:

- CS 12 Method of tensile testing of steel products other than sheet, strip, wire and tube.
- CS 91 Method of tensile testing of steel sheet and strip.
- CS 102 Presentation of numerical values
- CS 145 Method of Rockwell hardness test.
- SLS 238 Metal washers for general engineering purposes.
- SLS 239 Steel spring washers for general engineering purposes.
- SLS 268 ISO Metric screw threads.
- SLS 297:Part 4 Method of testing vulcanized rubber  
Determination of hardness.

For the purpose of deciding whether a particular requirement of this standard is complied with, the final value, observed or calculated, expressing the results of a test shall be rounded off in accordance with CS 102. The number of significant places retained in the rounded off

value should be the same as that of the specified value in this standard.

## 1 SCOPE

This specification covers requirements for bicycle brake shoe assembly components, namely, the brake block, brake shoe, their bolt, nut and washer for use in lever type brakes of standard sizes of bicycles.

## 2 REQUIREMENTS

### 2.1 Material

2.1.1 Brake blocks shall be made of natural rubber and have a hardness of 85 IRHD to 95 IRHD (International Rubber Hardness Degrees).

2.1.1.1 The test for hardness shall be carried out in accordance with SLS 297 Part 4.

2.1.2 Brake shoes shall be made from pressing quality rimming mild steel sheet or strip of thickness not less than 1.16 mm having a tensile strength of not less than 230 MPa\* (24 kgf/mm<sup>2</sup>) and conforming to the following chemical composition limits:

Element	Per cent max.
carbon	0.12
manganese	0.50
phosphorus	0.060
sulphur	0.060

---

\* 1 MPa =  $10^6$  Pa (pascal)

2.1.2.1 The test for tensile strength shall be carried out in accordance with CS 91.

2.1.3 Brake shoe bolts and nuts shall be made of steel having a tensile strength not less than 340 MPa (35 kgf/mm<sup>2</sup>), an elongation after fracture of not less than 10 per cent on a gauge length of  $5.65\sqrt{\text{area}}$  and conform to the following chemical composition limits:

Element	Per cent max.
carbon	0.13
manganese	0.60
sulphur	0.060
phosphorus	0.060

2.1.3.1 The test for tensile strength and elongation shall be carried out in accordance with CS 12.

2.1.4 Plain washers shall be made of pressing quality mild steel conforming to the following chemical composition limits:

Element	Per cent max.
carbon	0.12
manganese	0.50
phosphorus	0.050
sulphur	0.050

2.1.5 Spring washers shall be made of spring steel and shall conform to SLS 239.



## 2.2 Workmanship and finish

2.2.1 The shape of the brake block and the shoe shall be as given in Figs. 1 and 2 respectively, so as to facilitate tight fitting of the brake block with the shoe. The brake shoe bolt, nut and washer shall be accurate so as to facilitate tightening of the nut to keep the assembly free from any shake or play.

2.2.2 Brake shoes, bolts, nuts and washers shall be coated with either zinc, cadmium or nickel chrome.

## 2.3 Dimensions

2.3.1 Main dimensions for brake blocks shall be as given in Fig. 1.

*NOTE - The value for the radius of curvature of the braking surface of brake blocks in Fig. 1 is given only for purpose of guidance and need not strictly be followed.*

2.3.2 Main dimensions for brake shoes shall be as given in Fig. 2.

2.3.3 Main dimensions for brake shoe bolts shall be as given in Fig. 3.

2.3.4 Main dimensions for brake shoe nuts shall be as given in Fig. 4.

2.3.5 Main dimensions for plain washers shall be as given in Fig. 5 conforming to SLS 238.

2.3.6 Main dimensions for spring washers shall be as given in Fig. 6 conforming to SLS 239.

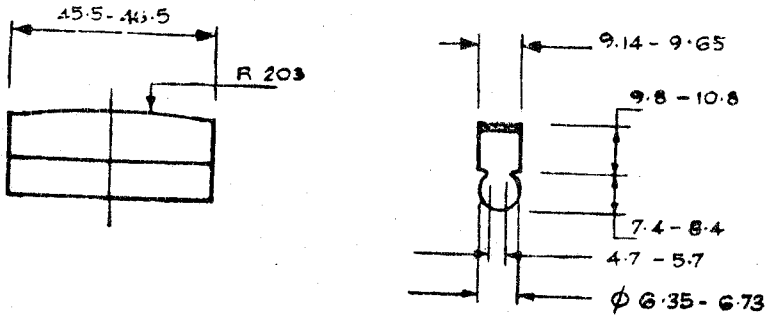

All dimensions in millimetres  
**FIGURE 1 - Dimensions of brake blocks**

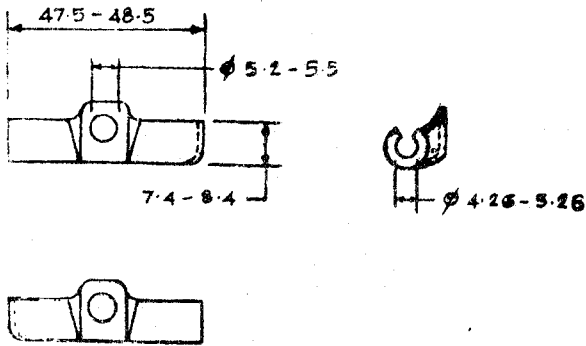

All dimensions in millimetres  
**FIGURE 2 - Dimensions of brake shoes**

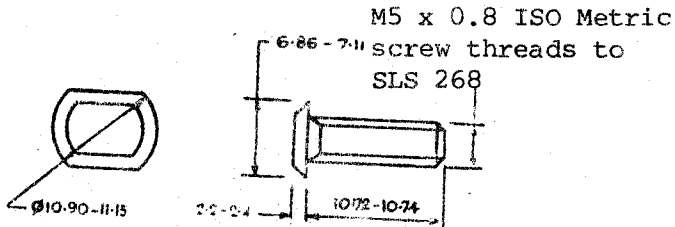

All dimensions in millimetres  
**FIGURE 3 - Dimensions of brake shoe bolts**

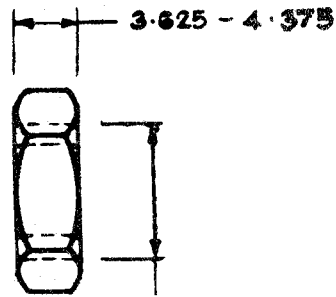
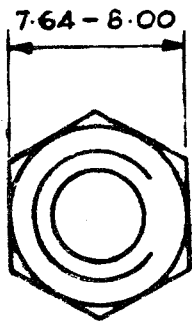

M5 x 0.8 ISO Metric  
screw

threads to SLS 268

All dimensions in millimetres

FIGURE 4 - Dimensions of brake shoe nuts

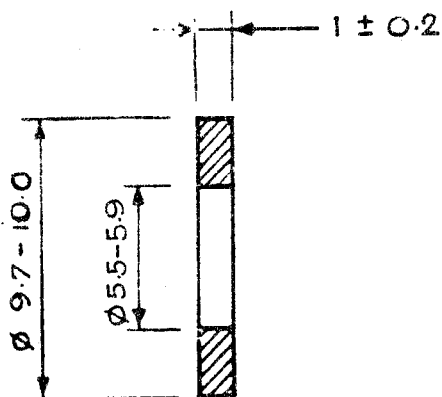

All dimensions in millimetres

FIGURE 5 - Dimensions of plain washers

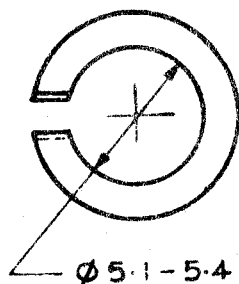
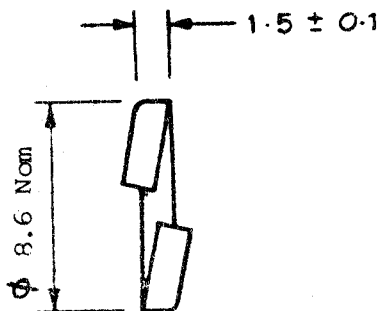

All dimensions in millimetres

FIGURE 6 - Dimensions of spring washers

### 3 PACKING

3.1 The brake shoe assemblies shall be wrapped in water-proof paper or by any other suitable material and then securely packed in suitable boxes.

### 4 MARKING

4.1 The package of brake shoe assemblies shall be attached with label or by other suitable means for clear indication of the following particulars:

- a) *Description of content;*
- b) *Quantity;*
- c) *Batch or code number;*
- d) *Name of manufacturer or registered trade mark; and*
- e) *The words "Made in Sri Lanka".*

### 5 SAMPLING

#### 5.1 Lot

All brake shoe assemblies of one consignment, manufactured under similar processes of production shall constitute a lot.

5.2 Each lot shall be considered separately for ascertaining conformity of the lot to the requirements of the specification. The number of brake shoe assemblies to be selected for this purpose, shall depend on the size of the lot and shall be in accordance with Columns 1 and 2 of Table 1.

5.3 Brake shoe assemblies shall be selected at random from the lot, to ensure randomness of selection, use shall be made of random number tables.

5.4 If the brake shoe assemblies in the lot are packed in different boxes/cases the suitable number of boxes/cases (not less than 20 per cent of the total in the lot subject to a minimum of 2) shall be chosen at random. From each of the boxes/cases so chosen an approximately equal number of brake shoe assemblies shall be picked up from the different parts so as to obtain the required number of brake shoe assemblies specified in Column 2 of Table 1.

TABLE 1 - Scale of sampling and criteria of conformity

Lot size	Sample size	Permissible no. of defectives
(1)	(2)	(3)
up to 50	5	0
51 100	8	0
101 300	13	1
301 1000	20	1
1001 3000	32	2
over 3000	50	3

## 6 INSPECTION

6.1 All brake shoe assemblies selected as in 5 shall be examined for the following:

- a) Material
- b) Workmanship and Finish
- c) Dimensions

Any brake shoe assembly which fails to satisfy this standard in any of the above characteristics shall be

considered as a defective brake shoe assembly.

## 7 CRITERIA FOR CONFORMITY

7.1 The lot shall be considered as conforming to the requirements of this standard if the number of defective brake shoe assemblies does not exceed the corresponding number given in Column 3 of Table 1, otherwise the lot shall be considered as not conforming to the requirements of this standard.

7.2 The sampling plan subject to which acceptance of a lot is determined in this standard, ensures that it will on the long run accept approximately 95 per cent of the lots, provided the process average level of per cent defectives (or number of defectives per 100 items) in these lots is not greater than the Acceptance Quality Level (AQL) value of 2.5.

## **SLS CERTIFICATION MARK**

*The Sri Lanka Standards Institution is the owner of the registered certification mark shown below. Beneath the mark, the number of the Sri Lanka Standard relevant to the product is indicated. This mark may be used only by those who have obtained permits under the SLS certification marks scheme. The presence of this mark on or in relation to a product conveys the assurance that they have been produced to comply with the requirements of the relevant Sri Lanka Standard under a well designed system of quality control inspection and testing operated by the manufacturer and supervised by the SLSI which includes surveillance inspection of the factory, testing of both factory and market samples.*

*Further particulars of the terms and conditions of the permit may be obtained from the Sri Lanka Standards Institution, 17, Victoria Place, Elvitigala Mawatha, Colombo 08.*



## **SRI LANKA STANDARDS INSTITUTION**

The Sri Lanka Standards Institution (SLSI) is the National Standards Organization of Sri Lanka established under the Sri Lanka Standards Institution Act No. 6 of 1984 which repealed and replaced the Bureau of Ceylon Standards Act No. 38 of 1964. The Institution functions under the Ministry of Science & Technology.

The principal objects of the Institution as set out in the Act are to prepare standards and promote their adoption, to provide facilities for examination and testing of products, to operate a Certification Marks Scheme, to certify the quality of products meant for local consumption or exports and to promote standardization and quality control by educational, consultancy and research activity.

The Institution is financed by Government grants, and by the income from the sale of its publications and other services offered for Industry and Business Sector. Financial and administrative control is vested in a Council appointed in accordance with the provisions of the Act.

The development and formulation of National Standards is carried out by Technical Experts and representatives of other interest groups, assisted by the permanent officers of the Institution. These Technical Committees are appointed under the purview of the Sectoral Committees which in turn are appointed by the Council. The Sectoral Committees give the final Technical approval for the Draft National Standards prior to the approval by the Council of the SLSI.

All members of the Technical and Sectoral Committees render their services in an honorary capacity. In this process the Institution endeavours to ensure adequate representation of all view points.

In the International field the Institution represents Sri Lanka in the International Organization for Standardization (ISO), and participates in such fields of standardization as are of special interest to Sri Lanka.