

SRI LANKA STANDARD 1077 : 1995
ISO 11644:1993

SRI LANKA STANDARD
LEATHER – TEST FOR ADHESION OF
FINISH

SRI LANKA STANDARDS INSTITUTION

**SRI LANKA STANDARD
LEATHER – TEST FOR ADHESION OF FINISH**

SLS 1077: 1995

Gr. D

**SRI LANKA STANDARDS INSTITUTION
No. 17, Victoria Place
Elvitigala Mawatha
Colombo 08
SRI LANKA.**

SLS 1077:1995
ISO 11644:1993

Sri Lanka standard
LEATHER – TESTS FOR ADHESION OF FINISH

NATIONAL FOREWORD

This standard was finalised by the Sectoral Committee on Textiles, Clothing and Leather and was authorized for adoption and publication as a Sri Lanka Standard by the Council of the Sri Lanka Standards Institution on 1995-10-26.

This Sri Lanka Standard is identical with ISO 11644 : 1993 Leather – Tests for adhesion of finish, published by the International Organization for Standardization. (ISO).

Terminology and Conventions

The text of the International Standard has been accepted as suitable for publication, without deviation, as a Sri Lanka Standard. However, certain terminology and conventions are not identical with those used in Sri Lanka Standards, attention is therefore drawn to the following :

- a). Wherever the words “ International standard/Publication” appear, referring to this Standard they should be interpreted as “Sri Lanka Standard”.
- b). Wherever page numbers are quoted, they are ISO page numbers.

INTERNATIONAL
STANDARD

ISO
11644

IULTCS/IUF
470

First edition
1993-12-15

Leather — Test for adhesion of finish

Cuir — Essai de l'adhésion du finissage



Reference number
ISO 11644:1993 (E)
IULTCS/IUF
470, 1993 Edition

Foreword

ISO (the International Organization for Standardization) is a worldwide federation of national standards bodies (ISO member bodies). The work of preparing International Standards is normally carried out through ISO technical committees. Each member body interested in a subject for which a technical committee has been established has the right to be represented on that committee. International organizations, governmental and non-governmental, in liaison with ISO, also take part in the work. ISO collaborates closely with the International Electrotechnical Commission (IEC) on all matters of electrotechnical standardization.

Draft International Standards adopted by the technical committees are circulated to the member bodies for voting. Publication as an International Standard requires approval by at least 75 % of the member bodies casting a vote.

International Standard ISO 11644 was prepared by the Fastness Tests Commission of the International Union of Leather Technologists and Chemists Societies (IUF Commission, IULTCS). It is based on IUF 470 published in *J. Soc. Leather Tech. Chem.*, **74**, pp. 155-160 (1990), and declared an official method of the IULTCS in September 1991.

Annexes A and B of this International Standard are for information only.

© ISO 1993

All rights reserved. Unless otherwise specified, no part of this publication may be reproduced or utilized in any form or by any means, electronic or mechanical, including photocopying and microfilm, without permission in writing from the publisher.

International Organization for Standardization
Case Postale 56 • CH-1211 Genève 20 • Switzerland

Printed in Switzerland

Introduction

A test method similar to that specified in this International Standard, using an epoxy adhesive and metal adherend-plates has been in use in the leather trade for many years, but has never been declared an official method by IULTCS or ISO. The adhesive frequently penetrates thin finish films, thus increasing the adhesion value unrealistically, and it is usually not possible to measure wet adhesion, as there is insufficient adhesion to the metal when water is present. Finishes with insufficient adhesion to the adhesive also occur quite frequently. In spite of these drawbacks, this old method has been used regularly and is referred to in many specifications. The new method specified in this International Standard eliminates most of these drawbacks.

The polyurethane adhesive used in the new method contains no solvent at the time of application to the finish and thus has a very high viscosity. It also stays viscous for only a few seconds, and there is no time for it to penetrate even very thin finishes, unless the finish has open cracks in it. While adhesion to most finishes is sufficient, a few cases exist in which adhesion is insufficient, and a different adhesive has to be used in such cases. As the adhesive does not penetrate, it is quite possible to test different layers of a multi-layer finish separately. Such a finish can be tested several times until all the layers have been removed from the leather. It would be advisable for specifications to make allowance for this fact.

A strip of hard PVC is used as the adherend-plate, this giving good adhesion under wet conditions. Wet adhesion can therefore be measured easily. Experience has shown that this "real" wet-adhesion value is often lower, a fact that should also be considered when drawing up specifications based on the new method.

This page intentionally left blank

Leather — Test for adhesion of finish

1 Scope

1.1 Depending on the way the leather has been finished, the adhesion of the finish to the leather can be so low over the whole area, or part of it, that the finish separates from the leather during use. With finishes consisting of several layers, the separation may occur between the layers, for example between the pigmented layer and the base coat. This International Standard specifies a method for measuring the adhesion of the finish to the leather or the adhesion between two adjacent layers of the finish.

1.2 The method is valid for all finished leathers with a smooth surface which can be bonded to an adherend-plate without the adhesive penetrating into the finish. Preliminary experiments may be necessary to determine whether these conditions obtain.

2 Normative references

The following standards contain provisions which, through reference in this text, constitute provisions of this International Standard. At the time of publication, the editions indicated were valid. All standards are subject to revision, and parties to agreements based on this International Standard are encouraged to investigate the possibility of applying the most recent editions of the standards indicated below. Members of IEC and ISO maintain registers of currently valid International Standards.

ISO 105-A02:1993, *Textiles — Tests for colour fastness — Part A02: Grey scale for assessing change in colour.*

ISO 2418:1972, *Leather — Laboratory samples — Location and identification.*

ISO 2419:1972, *Leather — Conditioning of test pieces for physical tests.*

ISO 3696:1987, *Water for analytical laboratory use — Specification and test methods.*

3 Definition

For the purposes of this International Standard, the following definition applies.

3.1 adhesion: The force required to pull the leather away from its surface finish layer, the force being applied steadily, at an angle of about 90° to a rigid adherend-plate to which the finished side of the leather has been bonded.

4 Principle

The finished side of part of a strip of leather is bonded to an adherend-plate by means of heat-reactivated adhesive film. Force is applied to the free end of the strip to peel the leather from the finish over a given distance, the finish layer remaining on the adherend-plate together with the film of adhesive. The force required is measured and reported as the adhesion of the finish to the leather.

The test is usually carried out on specimens conditioned in a standard atmosphere before testing. If required, the test may additionally be carried out on wetted specimens or on specimens which have previously been subjected to other agencies or preparations.

5 Apparatus and materials

5.1 Tensile-testing machine, operating vertically, incorporating the features specified in 5.1.1 to 5.1.4.

5.1.1 An appropriate range of measurable loads.

5.1.2 A speed of separation of the clamps of 100 mm/min \pm 5 mm/min.

5.1.3 Suitable means for fixing the adherend-plate holder (5.3) to the hook link (5.4).

5.1.4 Provision for recording a force-distance diagram during the test.

5.2 Adherend-plate, comprising a piece of hard PVC¹⁾, or other suitable material, measuring 70 mm × 20 mm × 3 mm, to which the leather specimen is bonded. PVC with a high IR absorption is preferred.

5.3 Adherend-plate holder (see figure 1), made for instance of aluminium, for holding the adherend-plate, to which the leather specimen has been bonded, in the lower clamp of the tensile-testing machine.

5.4 Hook link, made for instance of steel wire 1 mm to 2 mm in diameter, about 25 cm long, for attaching the free end of the leather specimen to the upper clamp of the tensile-testing machine (see figures 2 and 3).

5.5 Punch, suitable for making a hole 2 mm to 3 mm in diameter in the leather specimen.

5.6 Two-component polyurethane adhesive²⁾, comprising a resin and a hardener. Usually 20 g of solid resin is dissolved in 80 g of ethyl acetate and 5 g of hardener is added, unless otherwise instructed by the manufacturer of the adhesive. The adhesive shall be used within 8 h of addition of the hardener, unless otherwise instructed by the manufacturer of the adhesive.

5.7 IR lamp, capable of heating the adherend-plate (5.2) to 80 °C, or **oven**, capable of maintaining a temperature of 85 °C ± 3 °C, kept uniform by an air-circulation fan, for instance.

5.8 Weight-piece, of mass 4,5 kg, with a flat base.

5.9 Temperature-indicating substance³⁾, melting at 80 °C, to indicate when the surface temperature of the adherend-plate has reached 80 °C, when the IR lamp is being used.

5.10 Cleaning solvent: hexane or a mixture of alkanes boiling within the range 40 °C to 80 °C (e.g. petroleum ether), for cleaning the surface of the adherend-plate and the finished side of the leather specimen before bonding.

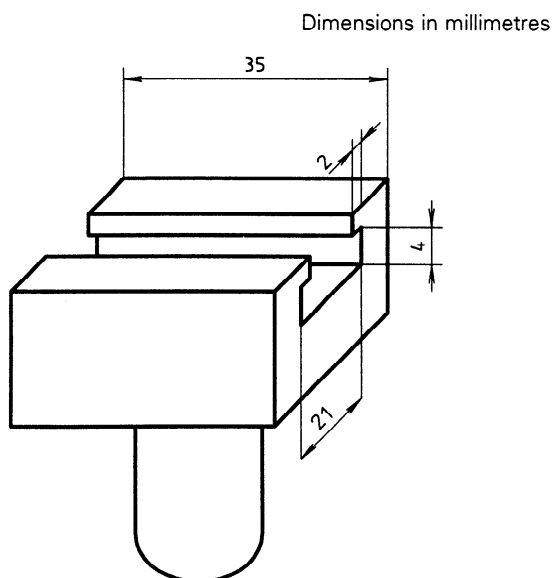

Figure 1 — Adherend-plate holder

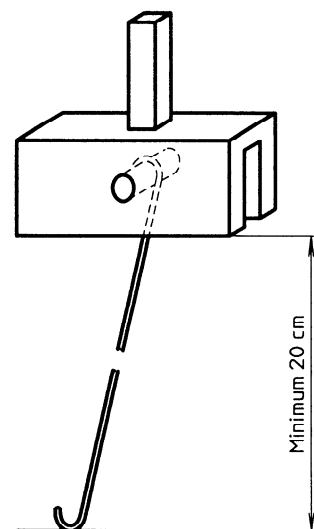

Figure 2 — Hook link

1) An example of a commercial source for suitable hard PVC plates is given in annex A.

2) An example of a commercial source for a suitable adhesive is given in annex A.

3) An example of a suitable temperature-indicating substance is given in annex A.

5.11 Cutter, capable of cutting a specimen of 100 mm × 10 mm from the leather with one stroke.

5.12 Apparatus for wetting the test specimen, comprising the elements specified in 5.12.1 to 5.12.3. (This is only required where wetted leathers are to be tested.)

5.12.1 Vacuum-desiccator vessel, or other glass container suitable for evacuation.

5.12.2 Vacuum pump, capable of evacuating the desiccator vessel (5.12.1) to 5 kPa (50 mbar) within 4 min.

5.12.3 Beaker, filled with distilled water at 20 °C in which the test specimens (leather bonded to adherend-plate) can be completely submerged.

5.13 Grey scale for assessing change in colour, in accordance with ISO 105-A02. (This is only required when the change in colour of the leather surface is to be assessed after undergoing the test and repolishing.)

5.14 Demineralized water, grade 3 in accordance with ISO 3696.

6 Preparation of test specimens

6.1 Location and number

From the piece of leather to be tested (or a laboratory sample cut from it, whichever is more suitable), cut out, with one stroke of the cutter (5.11), strips measuring 100 mm × 10 mm. If possible, the strip location shall be as specified in ISO 2418.

The adhesion of a finish to the leather may vary greatly, even within a single piece (skin, side, shoulder, etc.). It is therefore recommended that the leather specimens be taken not only from the positions specified in ISO 2418, but also from the shoulder and belly.

For each leather specimen location and each type of test specimen conditioning (usually at 20 °C and 65 % R.H. but, if required, also wetted, aged, etc.; see clause 7), take at least four leather specimens, two with their long axis parallel to and two with their long axis at right angles to the backbone.

6.2 Punching holes

Using the punch (5.5), make holes 2 mm to 3 mm in diameter at each end of the centreline of each strip, about 5 mm from the end.

6.3 Attachment of the leather specimen to the adherend-plate

6.3.1 Clean the surface of the adherend-plate (5.2) to which the leather specimen is to be bonded and the finished side of the leather with a clean piece of cloth wetted with solvent (5.10).

CAUTION — Use adequate ventilation and avoid contact of the solvent with the skin.

6.3.2 Apply the adhesive (5.6) as a thin layer to the cleaned surface of the adherend-plate with a brush, and then store at room temperature for at least 30 min. The adherend-plate with the adhesive shall be used within 8 h of application of the adhesive. Take care to apply the adhesive uniformly. For leathers with a coarse grain, several layers of adhesive shall be applied, in order to ensure that the grooves in the leather will be filled.

6.3.3 Heat the adhesive film on the adherend-plate to 80 °C either with the IR lamp [before preparing test specimens, check, using a spare adherend-plate and the temperature-sensitive substance (5.9), that the IR lamp does in fact heat the plate to 80 °C] or by placing in the oven for 10 min at 85 °C. Immediately afterwards, place the leather specimen with the finish down on the adhesive film, with the leather extending about 15 mm beyond each end of the plate, and then place the weight-piece (5.8) on the leather for at least 2 min.

NOTE 1 Especially when testing the adhesion of the finish of leathers with heavy prints, even adhesion can be ensured by rolling the upper surface of the leather with a hand roller, applying moderate pressure, before the weight-piece is placed on the test specimen.

7 Conditioning of the test specimens

7.1 The adhesion is normally determined on dry test specimens, conditioned in the standard atmosphere as described in 7.5. Whether, and the extent to which, other conditions have an effect on the adhesion can only be determined relative to the adhesion in the dry state.

7.2 Tests on wetted leather are often instructive. It shall be noted, however, that difficulties can arise as a result of uneven wetting or swelling of the leather, or the effect of the water on the adhesive.

If the leather is to be tested wet, allow the test specimen to stand for at least 16 h after bonding the leather to the adherend-plate, and then condition as follows:

Immerse the test specimen completely in demineralized water in the beaker (5.12.3). Place the beaker in the vacuum desiccator (5.12.1) and evacuate the desiccator to 5 kPa within 4 min. Hold the vacuum for 2 min and then release it. Repeat the evacuation/pressure-release process two more times. Leave the test specimen immersed in the water at 20 °C for a length of time such that the adhesion test is carried out at least 30 min, but not more than 120 min, after the time the test specimen was first immersed in the water. When the test specimen is taken out for testing, remove excess water with a filter paper, for instance.

7.3 Tests on artificially aged leathers can be used to predict the behaviour of a finish during long-term storage. A freshly applied finish may exhibit good adhesion, but this may deteriorate significantly on storage. The reverse is also possible, while the adhesion of some finishes does not change.

7.4 Types of conditioning other than those listed above may be relevant in particular cases, e.g. the determination of the adhesion of leather specimens which have previously been submitted to repeated flexing, either while dry or while wet.

7.5 All test specimens except those to be tested wet shall be conditioned in the standard atmosphere specified in ISO 2419 (20 °C and 65 % R.H.) for not less than 16 h before testing.

8 Procedure

8.1 Fix the holder (5.3) in the lower clamp of the tensile-testing machine (5.1).

8.2 Slide the conditioned test specimen (adherend-plate with leather specimen bonded to it) into the holder until one end of the plate is flush with one end of the holder.

8.3 Attach one end of the hook link (5.4) in the upper clamp of the tensile-testing machine and attach the other end to the leather specimen by hooking it into the hole at the end of it (see figure 3).

NOTE 2 For leathers with very high adhesion values (e.g. some patent leathers) it may be necessary to attach a suitable clamp to the leather specimen and to attach the hook link to that clamp instead of inserting it in the hole in the leather specimen.

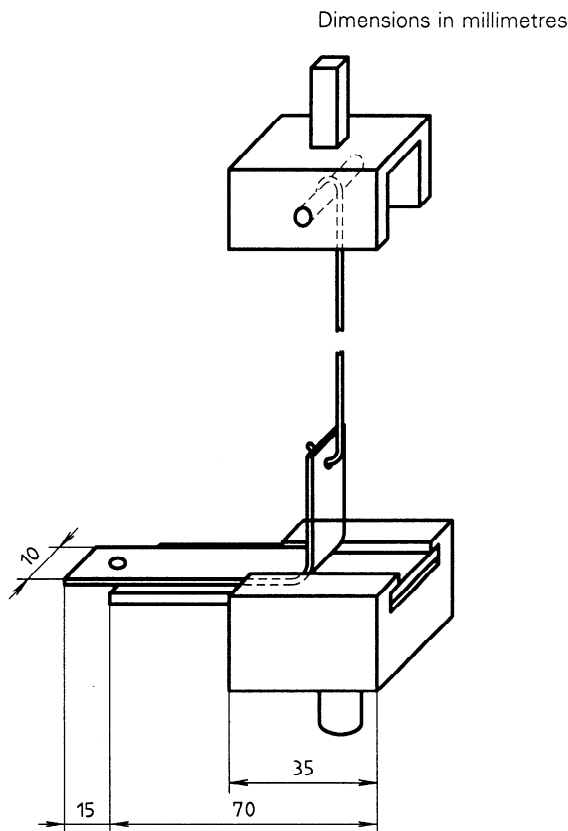

Figure 3 — Arrangement of test specimen and clamps for test

8.4 Switch on the tensile-testing machine at a speed of separation of the jaws of 100 mm/min \pm 5 mm/min, and record the force-distance diagram for the separation of the finish from the leather over a distance of 30 mm to 35 mm. Unhook the leather specimen.

Observe how the finish separates from the leather. Report the appearance of the leather and film after the test, especially the way in which the finish has separated, e.g. as a smooth film or as individual layers, as well as details of any failures in the test specimen which may not be revealed by the force-distance diagram, e.g. separation of the adhesive bond from the adherend-plate or tearing of the leather. If adhesion failure occurs, the adhesion value for that particular determination shall not be used to calculate a mean adhesion value. If adhesion failure

occurs with all the specimens, reject the results and repeat the test using a different method of adhesion.

If the finish remains mostly on the leather, change the method of bonding and repeat with a new test specimen.

If the leather is coated with a thick finish (e.g. patent leather) or laminated with a film, make a cut through the finish, across the width of the leather specimen, just beyond that end of the adherend-plate where separation will begin. This ensures that the tensile properties of the finish will not influence the results.

8.5 Reverse the direction of the test specimen in the holder. Repeat the test in the opposite direction.

The adhesion of the finish to the leather may vary with the direction of the hair follicles, and with the buffing direction in corrected-grain leathers. It is therefore essential to measure the adhesion of the finish in both directions on each leather specimen.

8.6 Determine, from each force-distance diagram obtained, the mean adhesion of the finish to the leather over about 30 mm of the leather specimen, i.e. the adhesion value (see figure 4), and record this

value, expressed in newtons per 10 mm, rounded to the nearest 0,1 N/10 mm. In addition, for each test-specimen condition (dry, wet, etc.), calculate and record the mean of all adhesion values obtained.

The force-distance diagram is best evaluated by means of a planimeter. The area under the curve, divided by the distance over which separation of the finish has been measured, gives the height corresponding to the mean adhesion value. As long as the diagram is not too irregular, the mean value can also be estimated visually with reasonable accuracy. If the force-distance diagram shows an initial surge peak, disregard this peak for the determination of the adhesion value.

Strictly speaking, comparison of results obtained on different types of leather is not possible, since the adhesion values are particularly affected by the stiffness of the leather. If the results for different types of leather are to be compared, the difference in stiffness of the leathers must be taken into consideration. When testing the adhesion of the finish to very thick leathers, it may be necessary to reduce the thickness of the leather specimen. When doing so, the finish shall be protected, e.g. with a sheet of paper. If the leather is split before testing, this shall be mentioned in the test report.

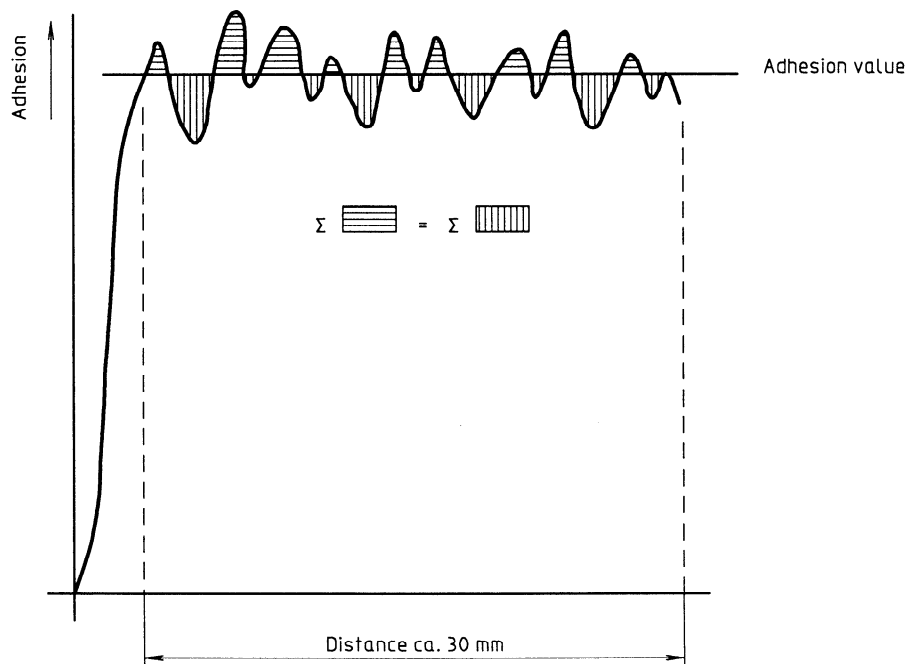

Figure 4 — Evaluation of force-distance diagram

8.7 If required, assess the differences in colour between the surface from which the finish has been removed, the same surface after it has been polished, and the original finished leather, using the grey scale in accordance with ISO 105-A02.

NOTE 3 If the leather has not been dyed, or has been dyed in a colour which does not match the finish, the colour of the leather surface from which the finish has been removed will differ to a greater or lesser extent from that of the original finished leather.

9 Test report

The test report shall include the following information:

- a) a reference to this International Standard;
- b) a description of the type of leather tested;
- c) the adhesive used;
- d) the number of leather specimens tested, the positions from which they were taken and details of the conditioning procedure used;
- e) the adhesion values determined, in newtons per 10 mm, giving, for each individual leather specimen, the value for each direction of test (stating the direction of test) plus the overall mean of these values from all the leather specimens tested under the same conditions;
- f) the way in which the finish separated from the leather (see 8.4);
- g) if required, the numerical rating for the differences in colour between the leather with the finish intact and the leather after removal of the finish and polishing;
- h) details of any deviations from the procedure.

Annex A

(informative)

Commercial sources for apparatus and materials

Examples of suitable products available commercially are given below. This information is given for the convenience of users of this International Standard and does not constitute an endorsement by ISO of these products.

A.1 Pieces of hard PVC, measuring 70 mm × 20 mm × 3 mm, to be used as adherend-plates, may be obtained in lots of 100 or 1 000 from EMPA, Unterstrasse 11, CH-9001 St. Gallen, Switzerland.

A.2 Desmocoll 400 (resin) and Desmodur L 75 (hardener), which are the trade-names of products supplied by Bayer AG, D-5900 Leverkusen, Germany, are suitable as adhesive. Other two-component PU adhesives whose components react at 80 °C may be used if they can be shown to lead to the same results.

A.3 A suitable temperature-indicating substance is Merck Art. 9680 (E. Merck, Frankfurter Strasse 250, D-6100 Darmstadt, Germany).

Annex B (informative)

Bibliography

The following IULTCS publications describe related methods:

- [1] IUF 120, *General principles of colour fastness testing of leather.*
- [2] IUP 2, *Sampling.*
- [3] IUP 3, *Conditioning.*
- [4] IUP 20, *The measurement of the flexing endurance of light leathers and their surface finishes.*

This page intentionally left blank

UDC 675.026.3:620.179.4

Descriptors: leather, finishing, tests, adhesion tests.

Price based on 8 pages

SRI LANKA STANDARDS INSTITUTION

The Sri Lanka Standards Institution (SLSI) is the National Standards Organization of Sri Lanka established under the Sri Lanka Standards Institution Act No. 6 of 1984 which repealed and replaced the Bureau of Ceylon Standards Act No. 38 of 1964. The Institution functions under the Ministry of Science & Technology.

The principal objects of the Institution as set out in the Act are to prepare standards and promote their adoption, to provide facilities for examination and testing of products, to operate a Certification Marks Scheme, to certify the quality of products meant for local consumption or exports and to promote standardization and quality control by educational, consultancy and research activity.

The Institution is financed by Government grants, and by the income from the sale of its publications and other services offered for Industry and Business Sector. Financial and administrative control is vested in a Council appointed in accordance with the provisions of the Act.

The development and formulation of National Standards is carried out by Technical Experts and representatives of other interest groups, assisted by the permanent officers of the Institution. These Technical Committees are appointed under the purview of the Sectoral Committees which in turn are appointed by the Council. The Sectoral Committees give the final Technical approval for the Draft National Standards prior to the approval by the Council of the SLSI.

All members of the Technical and Sectoral Committees render their services in an honorary capacity. In this process the Institution endeavours to ensure adequate representation of all view points.

In the International field the Institution represents Sri Lanka in the International Organization for Standardization (ISO), and participates in such fields of standardization as are of special interest to Sri Lanka.

SLS CERTIFICATION MARK

The Sri Lanka Standards Institution is the owner of the registered certification mark shown below. Beneath the mark, the number of the Sri Lanka Standard relevant to the product is indicated. This mark may be used only by those who have obtained permits under the SLS certification marks scheme. The presence of this mark on or in relation to a product conveys the assurance that they have been produced to comply with the requirements of the relevant Sri Lanka Standard under a well designed system of quality control inspection and testing operated by the manufacturer and supervised by the SLSI which includes surveillance inspection of the factory, testing of both factory and market samples.

Further particulars of the terms and conditions of the permit may be obtained from the Sri Lanka Standards Institution, 17, Victoria Place, Elvitigala Mawatha, Colombo 08.

