

SRI LANKA STANDARD 240:1973
UDC 003.5:372.2

**SPECIFICATION FOR
SCHOOL SLATES**

BUREAU OF CEYLON STANDARDS

SPECIFICATION FOR SCHOOL SLATES

SLS 240:1973

Gr.3



Copyright Reserved

BUREAU OF CEYLON STANDARDS
53, Dharmapala Mawatha,
Colombo 3,
Sri Lanka.

Sri Lanka Standards are subject to periodical revision in order to accommodate the progress made by industry. Suggestions for improvement will be recorded and brought to the notice of the Committees to which the revisions are entrusted.

This Standard does not purport to include all the necessary provisions of a contract.

SRI LANKA STANDARD

SPECIFICATION FOR SCHOOL SLATES

FOREWORD

This Sri Lanka Standard Specification has been prepared by the Drafting Committee on School Slates. It was approved by the Civil Engineering Divisional Committee of the Bureau of Ceylon Standards and was authorised for adoption and publication by the Council of the Bureau on 1973-12-10.

Presently school slates are being manufactured locally in considerable quantities. While the quality of some slates is satisfactory there are a number of manufacturers who have introduced to the market, slates of a questionable quality. In view of this situation, it was considered desirable to lay down a Sri Lanka Standard Specification for school slates.

In view of the adoption of the metric system in Sri Lanka, it has been considered necessary to specify two series of dimensions for slates in order to facilitate the change-over from one system to another. A series of metric dimensions is given in Table 1. A second series of dimensions given in Table 2 are those of slates which are presently manufactured in the country. Other characteristics in this specification are given in metric units and the inch-pound equivalents of these values are given in parenthesis.

For the purpose of deciding whether a particular requirement of this standard is complied with, the final value observed or calculated expressing the result of a test or observation shall be rounded off in accordance with CS 102*. The number of figures to be retained in the rounded off values shall be the same as that of the specified value in this standard.

1 SCOPE

This Sri Lanka Standard Specification covers the requirements, methods of test and sampling of school slates.

2 REQUIREMENTS

2.1 Requirements for frames

2.1.1 The timber used for framing shall be seasoned to a moisture content between 12 per cent to 15 per cent and shall be free from the following defects.

a) *Check*

A separation of the fibres along the grain forming a crack or fissure in the timber not extending through the piece from one surface to another (of split). It generally results from stresses set up in the timber during seasoning; the term is usually applied to converted timber.

b) *Split*

A separation of the fibre along the grain forming a crack or fissure that extends through the piece from one surface to another.

*CS 102 *Presentation of numerical values.*

c) *Knot*

A portion of a branch enclosed in the wood by the natural growth of the tree.

d) *Worm or borer hole*

A hole or tunnel, irrespective of size, caused by insects or their larvae.

e) *Spring*

Curvature such that if the piece of timber is laid on its edge, it forms a flat arch.

f) *Bow*

Curvature such that the face is concave or convex along the grain.

g) *Decay (Rot)*

Decomposition by fungi and other micro organisms resulting in softening, progressive loss of strength and mass and often a change of texture and colour.

2.1.2 The frames shall be sanded so that surfaces are reasonably smooth. The corners and the joints shall be rounded. The joints shall be nailed and filled with a glue. The nails shall not project out of the surfaces of the frame.

2.1.3 *Frame strength*

Frame strength when tested by the method described in 5.1 shall not be less than 500 N (51.0 kgf, 112 lbf).

2.2 *Requirements for slates*

2.2.1 *Surface*

The surface of slate shall be such that the texture over the entire writing surface shall be even and the surface

itself should be even. The texture shall be smooth, with just sufficient roughness to enable the slate pencil to make a legible mark without undue pressure. Markings made on the slate with the use of a slate pencil shall not form a severely cut impression when wiped off with a dry cloth.

2.2.2 Colour

The colour of the slate shall be black and shall be reasonably uniform throughout the entire surface. The colour fastness shall comply with the requirements of 5.3.

2.2.3 Dimensions

The dimensions of slates shall conform to the requirements given in Table 1 or Table 2.

2.2.4 Mass

The mass of the slate inclusive of the frame shall be within the following limits:

Type A - 170 g to 350 g (6.0 oz to 12.3 oz)

Type B - 225 g to 400 g (7.9 oz to 10.1 oz)

2.2.5 Thickness

The thickness of the slates shall not be less than 2.5 mm (3/32 inch).

2.2.6 Transverse strength

The transverse strength of the slate when tested by the method described in 5.2 shall not be less than 20 N (2.0 kgf, 4.5 lbf).

TABLE 1 - Dimensions of school slates

Description	Unit mm	
	With the frame	Without the frame
Type A	170 x 220	135 x 180
Type B	200 x 250	165 x 215
		Writing surface
		125 x 175
		155 x 205

Tolerance on any dimension shall be ± 3 mm.

TABLE 2 - Dimensions of school slates

Description	Unit in.	
	With the frame	Without the frame
Type A	6.5 x 8.5	5 x 7
Type B	7.5 x 9.5	6 x 8
		Writing surface
		4.7 x 6.7
		5.7 x 8.7

Tolerance on any dimension shall be ± 0.1 inch.

2.2.7 Resistance to breakage on impact

A brass sphere of weight 30 ± 1 g is made to strike the centre of the slate from a distance of 30 cm as described in 5.4. The slates shall show no cracks.

3 SAMPLING AND CRITERIA FOR CONFORMITY

Samples of school slates for testing shall be taken at random from stocks aged not less than 2 weeks from the date of manufacture and shall consist of 13 slates per batch of 500 slates or part thereof. The manufacturer or supplier shall afford every facility and provide all the labour and materials for selection and packing of samples for testing.

If two or more slates out of 13 selected fail to comply with the requirements given in this standard, then the batch is deemed not to conform to this standard.

4 MARKING

Each slate shall be marked with the following:

- a) overall size of the slate;
- b) the brand or trade name if any,
- c) batch or code number, and
- d) the words "product of Sri Lanka".

5 METHODS OF TEST

5.1 Determination of frame strength

5.1.1 Apparatus

Tensile tester.

5.1.2 Procedure

The test specimen shall be firmly clamped, squarely in the jaws of the clamps. The stressing jaw shall then be

operated at a uniform rate of 300 mm per minute (12 in/min) until the frame of the slate breaks. Express the result in newtons.

5.2 Transverse test for slates

From each specimen, selected, in accordance with the clause on sampling (3), the frames shall be removed and placed on self aligning bearers *A* and *B*, each of length 250 mm (10 in) (see Figure 1). Bearer *A* shall be supported horizontally on two brass screws *C* which carry hardened steel balls *D* concentric with the bearer. Bearer *B* shall be supported on one such bearer screw and ball. The bearers *A*, *B* and *E* shall be mild steel 40 mm (1½ in) diameter. The bearers *A* and *B* shall be provided with two springs which shall hold them in position. The bearers *A* and *B* shall be in the same horizontal planes, parallel to each other and to bearer *E*. The distance between bearers *A* and *B* at the points of contact with the test specimen shall be 125 mm (5 in). Bearer *E* shall be midway between bearers *A* and *B* and shall rest on the upper surface of the test specimen.

The load shall be applied at a uniform rate of 100 newtons (10 kgf, 22 lbf) per minute through the bearer *E* with a permissible variation of ± 10 per cent in the rate.

5.3 Colour fastness test

When the surface of the slate is rubbed five times with a wet piece of cloth, the wet cloth shall not be blackened and also there shall not be any patches produced on the surface of the slate.

5.4 Determination of resistance to breakage on impact

5.4.1 Apparatus

Brass sphere weighing 30 ± 1 g.

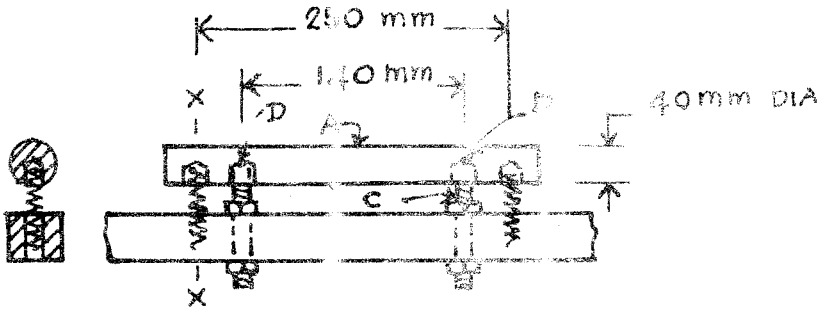
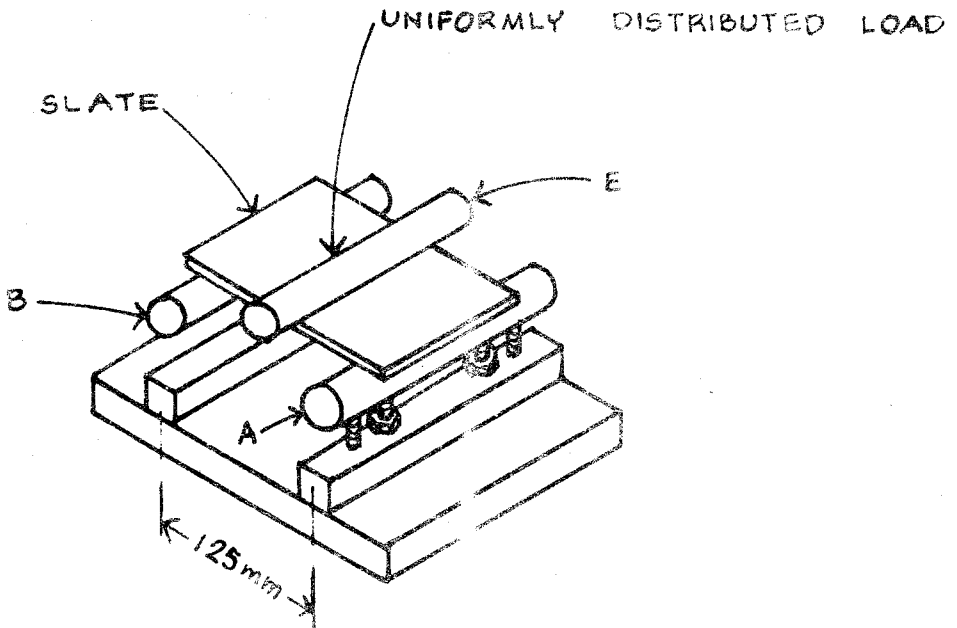

SECTION X-X DETAIL BEARER A

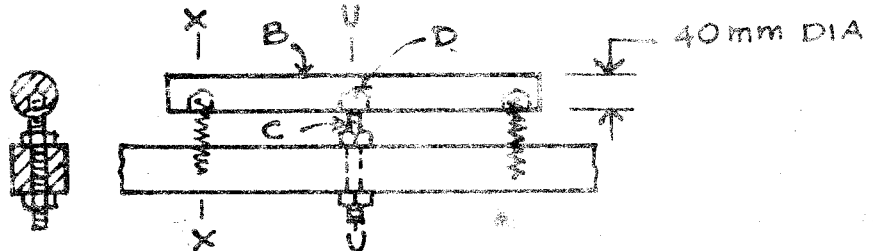

SECTION U-U DETAIL BEARER B

5.4.2 Procedure

The slate is fixed in a vertical plane by means of clamps. A brass sphere weighing 30 ± 1 g is suspended 50 cm from the centre of the slate at a point A directly above the slate, lying in the same plane as the slate. The sphere is brought 30 cm away from the plane of the slate as shown in Figure 2 and released gently. The slate is observed for any cracks.

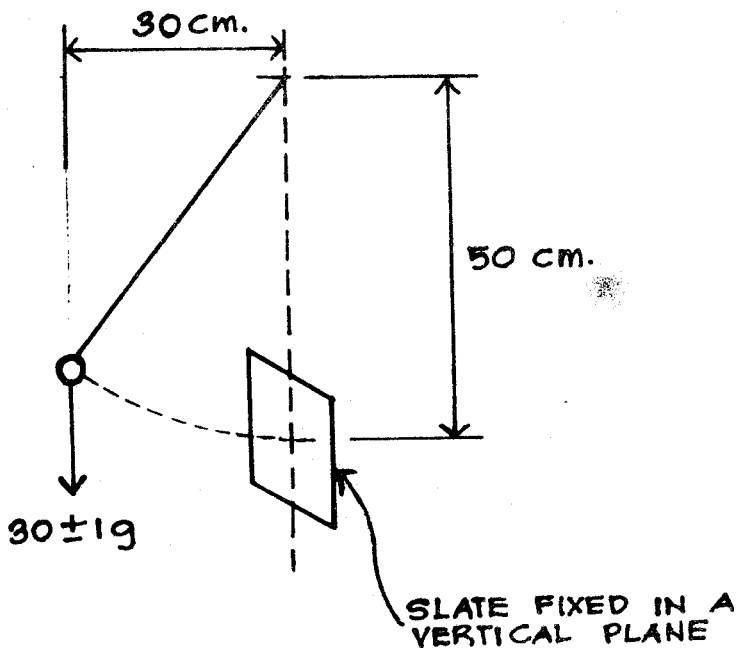

FIGURE 2-Impact test

SLS CERTIFICATION MARK

The Sri Lanka Standards Institution is the owner of the registered certification mark shown below. Beneath the mark, the number of the Sri Lanka Standard relevant to the product is indicated. This mark may be used only by those who have obtained permits under the SLS certification marks scheme. The presence of this mark on or in relation to a product conveys the assurance that they have been produced to comply with the requirements of the relevant Sri Lanka Standard under a well designed system of quality control inspection and testing operated by the manufacturer and supervised by the SLSI which includes surveillance inspection of the factory, testing of both factory and market samples.

Further particulars of the terms and conditions of the permit may be obtained from the Sri Lanka Standards Institution, 17, Victoria Place, Elvitigala Mawatha, Colombo 08.



SRI LANKA STANDARDS INSTITUTION

The Sri Lanka Standards Institution (SLSI) is the National Standards Organization of Sri Lanka established under the Sri Lanka Standards Institution Act No. 6 of 1984 which repealed and replaced the Bureau of Ceylon Standards Act No. 38 of 1964. The Institution functions under the Ministry of Science & Technology.

The principal objects of the Institution as set out in the Act are to prepare standards and promote their adoption, to provide facilities for examination and testing of products, to operate a Certification Marks Scheme, to certify the quality of products meant for local consumption or exports and to promote standardization and quality control by educational, consultancy and research activity.

The Institution is financed by Government grants, and by the income from the sale of its publications and other services offered for Industry and Business Sector. Financial and administrative control is vested in a Council appointed in accordance with the provisions of the Act.

The development and formulation of National Standards is carried out by Technical Experts and representatives of other interest groups, assisted by the permanent officers of the Institution. These Technical Committees are appointed under the purview of the Sectoral Committees which in turn are appointed by the Council. The Sectoral Committees give the final Technical approval for the Draft National Standards prior to the approval by the Council of the SLSI.

All members of the Technical and Sectoral Committees render their services in an honorary capacity. In this process the Institution endeavours to ensure adequate representation of all view points.

In the International field the Institution represents Sri Lanka in the International Organization for Standardization (ISO), and participates in such fields of standardization as are of special interest to Sri Lanka.