

SRI LANKA STANDARD 567 : 1982

UDC 621.791.927

**SPECIFICATION FOR
ELECTRIC MANUAL ARC WELDING
ELECTRODES FOR HARDFACING**

BUREAU OF CEYLON STANDARDS

SPECIFICATION FOR ELECTRIC MANUAL ARC WELDING
ELECTRODES FOR HARDFACING

SLS 567 : 1982

Gr. 13

Copyright Reserved

BUREAU OF CEYLON STANDARDS

53, Dharmapala Mawatha,

Colombo 3,

Sri Lanka.

CONSTITUTION OF THE DRAFTING COMMITTEE

CHAIRMAN

Mr. S.C. Bamunuarachchi

REPRESENTING

Bureau of Ceylon Standards

MEMBERS

Mr. N. Asogan

Colombo Dockyard Limited

Mr. P.R.H.N. Fernando

Ceylon Petroleum Corporation

Mr. L.J. Jeyasingham

Brown & Company

Mr. K. Kalanithy

Government Factory

Mr. R. Wijewardena

Ceylon Steel Corporation

TECHNICAL SECRETARIAT

BUREAU OF CEYLON STANDARDS

Sri Lanka Standards are subject to periodical revision in order to accommodate the progress made by industry. Suggestions for improvement will be recorded and brought to the notice of the Committees to which the revisions are entrusted.

This standard does not purport to include all the necessary provisions of a contract.

SRI LANKA STANDARD
SPECIFICATION FOR ELECTRIC MANUAL ARC WELDING
ELECTRODES FOR HARDFACING

FOREWORD

This Sri Lanka Standard was authorised for adoption and publication by the Council of the Bureau of Ceylon Standards on 1982-05-24, after the draft finalised by the Drafting Committee on Electric Manual Arc Welding Electrodes for Hardfacing has been approved by the Mechanical Engineering Divisional Committee.

All values in this standard have been given in metric units.

Hardfacing arc welding electrodes are widely used in industry. Their main application is to build up various machine components, which are subjected to wear erosion and impact. This standard is expected to provide guidance to users, manufacturers and importers of this item.

For the purpose of deciding whether a particular requirement of this standard is complied with, the final value, observed or calculated, expressing the result of a test or observation, shall be rounded off in accordance with CS 102. The number of figures to be retained in the rounded off values shall be the same as that of the specified value in this standard.

Assistance derived from the publications of the American National Standards Institution, the British Standards Institution, the Indian Standards Institution and Japanese Standards Association in the preparation of this standard is gratefully acknowledged.

1 SCOPE

This Sri Lanka Standard covers the range of standard electric arc welding electrodes for hardfacing.

2 REFERENCES

- CS 102 Presentation of numerical values
- CS 122 Vickers hardness test
- SLS 428 Random sampling methods

3 DEFINITIONS

For the purpose of this standard, the following definitions shall apply:

3.1 arc welding : Fusion welding in which heat for welding is obtained from an electric arc or arcs.

3.2 deposition efficiency : The ratio of the mass of deposited metal to the net mass of core wire of electrodes consumed, exclusive of stubs.

3.3 flux : Fusible material used in welding or in oxygen cutting to dissolve and facilitate removal of oxides and other undesirable substances. Also commonly used to designate coating of covered electrodes.

3.4 metal arc welding : Arc welding with a metal electrode or electrodes, the melting of which provides the filler metal.

3.5 stubs : Waste ends of electrodes and welding rods.

4 CLASSIFICATION OF WELDING ELECTRODES

The object of hardfacing is to deposit a layer of weld metal on machine components requiring resistance to abrasion, erosion and impact.

The service conditions of erosion are very much akin to that of abrasion and are considered to be so for the purpose of classification.

4.1 The welding electrodes shall be classified on the basis of :

4.1.1 The degree of abrasive resistance, erosion resistance and impact resistance of the weld deposit;

4.1.2 The micro structure of the weld deposit;

4.1.3 The hardness of the weld deposit; and

4.1.4 The chemical composition of the deposited metal (see Table 1).

NOTE - The nominal chemical composition shall be given under classification for any hardfacing welding electrode which cannot be classified according to Table 1.

TABLE 1 - Chemical composition of weld deposits
From surfacing electrodes (4.1.4 and A.2.1)

1	2	3	4	5	6	7	8	9	10	11	12	13	14
Code	C	Mn	Co	W	Ni	Cr	Mo	Fe	V	Si	S	P	B
E HSS	A	0.7-1.0	-	5.0-7.0	-	3.0-5.0	4.0-6.0	bal.	1.0-2.5	0.70	0.03	0.03	-
	B	0.5-0.9	-	1.0-2.5	-	3.0-5.0	5.0-9.5	bal.	0.8-1.3	0.70	0.03	0.03	-
	C	0.3-0.5	-	1.0-2.5	-	3.0-5.0	5.0-9.0	bal.	0.8-1.2	0.70	0.03	0.03	-
E Fe Mn	A	0.5-0.9	-	-	2.75-6.0	0.50	-	bal.	-	1.3	0.03	0.03	-
	B	0.5-0.9	-	-	-	0.50	0.6-1.4	bal.	-	0.3-1.3	0.03	0.03	-
E Fe Cr	A	0.15	-	-	2.0-4.0	16-19	-	bal.	-	0.5	0.03	0.03	-
	B	3.0-5.0	-	-	-	26-32	-	bal.	-	1.0-2.5	0.03	0.03	-
	C	3.0-5.0	-	-	2.5-4.5	26-32	-	bal.	-	0.5-2.0	0.03	0.03	-
E Co Cr	A	0.7-1.4	bal.	3.0-6.0	3.0	25-32	1.0	5.0	-	0.4-2.0	0.03	0.03	-
	B	1.0-1.7	bal.	7.0-9.5	3.0	25-32	1.0	5.0	-	0.4-2.0	0.03	0.03	-
	C	1.75-3.0	bal.	11-14	3.0	25-32	1.0	5.0	-	0.4-2.0	0.03	0.03	-
E Cr Ni Mn	A	0.15	-	-	4.0-6.0	17-19	-	bal.	-	0.5	0.03	0.03	-
	B	0.15	-	-	8.0-11.0	18-20	-	bal.	-	0.5	0.03	0.03	-
E Ni Cr	A	0.3-0.6	1.5	-	75-85	8-14	-	1.25-3.25	-	1.25-3.25	-	0.03	2.0-3.0
	B	0.4-0.8	1.25	-	71-81	10-16	-	3.0-5.0	-	3.5	-	0.03	2.0-4.0
	C	0.5-1.0	1.00	-	65-75	12-18	-	5.5	-	3.5-5.5	-	0.03	2.5-4.0

Notes

- 1 Analysis given are of the deposited weld metal.
- 2 Single values shown are the maximum percentages, except where otherwise specified.

4.2 The letter E at the beginning of each classification indicates an electrode.

4.3 Any electrode classified under one classification shall not be classified under any other classification.

NOTE - A guide to classification is given in Appendix A.

5 REQUIREMENTS

5.1 Material

The material for core wire and flux coating of the hardfacing electrodes shall be such that they yield a product conforming to the requirements of this specification.

5.2 Workmanship and finish

5.2.1 The contact end of the electrode shall be bare and clean over a length of 20 mm to 30 mm.

5.2.2 The arc-striking end of the electrode shall permit easy striking of the arc. When the end is bare the distance from the arc end to the first point where full cross-section of the coating prevails shall not exceed the diameter of the core wire, subject to a maximum of 2.5 mm.

5.2.3 The flux coating shall be sufficiently robust to withstand without damage normal conditions of handling, storage and use.

5.2.4 The flux coating shall be uniform in outside diameter and in thickness. The tolerance permitted for uniformity of the flux coating shall be such that the core plus one maximum coating dimension (see Fig. 1) shall not exceed the core plus one minimum coating dimension by more than:

a) 5 per cent of the mean of the two dimensions in the case of electrodes with cast core wires; and

b) 3 per cent of the mean of the two dimensions in the case of electrodes with drawn core wire.

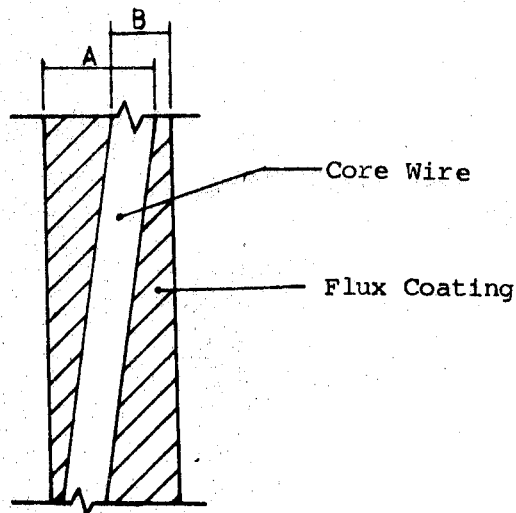

FIGURE 1 - Uniformity of the flux coating

$$A - B \leq \frac{5}{100} \frac{(A + B)}{2} \text{ for cast core wire}$$

$$A - B \leq \frac{3}{100} \frac{(A + B)}{2} \text{ for drawn core wire}$$

where,

A = core-plus-one maximum coating dimension, and

B = core-plus-one minimum coating dimension.

5.2.5 The flux coating shall fuse or burn or both evenly and be such that heating of the electrode during welding shall not cause injurious blistering or flaking of the coating within the range of current recommended by the manufacturer.

5.2.6 Core wire and coating shall be free from defects which would interfere with uniform performance of the electrodes.

5.2.7 The flux shall not include any material which on fusion would produce any toxic gases in quantities that could be a health hazard.

5.3 Dimensions and tolerances

5.3.1 Dimensions of core wire

The electrode core wire dimensions shall be as given in Table 2.

TABEL 2 - Dimensions of core wire

Diameter (mm)	3.15	4.0	5.0	6.0
Length (mm)	350	350	400	400

5.3.2 Tolerance on core wire

5.3.2.1 Tolerance on length

The tolerances on length for core wire of all diameters shall be ± 3 mm.

5.3.2.2 Tolerance on diameter

The tolerances on diameter of core wire shall be $\begin{matrix} + 0.00 \\ - 0.05 \end{matrix}$ mm on any diameter.

5.4 Properties and performance

5.4.1 Welding electrodes shall deposit smoothly without excessive spatter and with constant arc stability, when used within the current ranges recommended by the manufacturer. The slag shall be readily removable with hand tools.

5.4.2 The weld deposit when ground to clean the surface shall give a sound weld free from blow holes, slag inclusion, cracks and spatter under the specified conditions.

5.4.3 When tested according to the test specified in 8.1 the welding electrodes shall give weld deposits conforming to the relevant chemical composition given in Table 1.

5.4.4 When tested according to the test specified in 8.2 the welding electrodes shall give weld deposits conforming to the microstructure given in Table 3 as relevant.

TABLE 3 - Microstructure of weld deposits

Symbol	Microstructure
1	Pearlitic steel
2	Martensitic steel
3	Austenitic steel
4	Martensitic iron
5	Chromium carbide austenitic iron
6	Carbide composite
7	Cobalt based alloys

5.4.5 When tested according to the test specified in 8.3 the welding electrode, shall give weld deposits conforming to the relevant hardness values given in Table 4.

TABLE 4 - Hardness of weld deposits

Class	Hardness vickers (HV)
a	150 - 200
b	201 - 350
c	351 - 550
d	551 - 700
e	701 - 800
x	801 and above

6 PACKAGING

6.1 Electrodes shall be suitably packed to guard against damage during transportation and handling.

6.2 The net mass of a package shall not exceed 7 kg.

6.3 The packages of electrodes shall be moisture proof.

7 MARKING

The packages of electrodes shall be clearly marked with the following information :

- a) Name of manufacturer ;
- b) Manufacturer's trade mark ;
- c) Batch number ;
- d) Size of electrode and net mass of package ;
- e) Type of coating: Rutile, Lime, other ;
- f) Nominal chemical composition ;
- g) Deposition efficiency ;
- h) Single bead hardness of deposit ;
- j) Electrode polarity for D.C. operation ;
- k) Current, voltage specification ;
- l) Storage and baking condition, and
- m) Welding technique: position, pre heat, post heat etc

8 METHOD OF TEST

8.1 Test for chemical composition of weld deposits

8.1.1 A chemical analysis pad shall be prepared as described in B.1 of Appendix B, using fusion welding quality structural steel.

8.1.2 The top surface of the test pad shall be removed and discarded and an adequate sample of weld metal, sufficient for retest if necessary, shall then be removed from the test pad by any appropriate means. Post heat treatment may be used to soften the test pad to facilitate removal. Metal for the sample shall not be removed closer than 6 mm from the base metal. No oil or other lubricant shall be used when removing the sample.

8.1.3 Chemical analysis may be made by any accepted standard method agreed upon between the manufacturer and the purchaser.

8.2 Test for microstructure of weld deposits

Test for the microstructure of weld deposit shall be carried out according to a standard metallographic method agreed upon between the manufacturer and the purchaser.

8.3 Test for hardness of the weld deposit

8.3.1 Test pad shall be prepared as described in B.2 of Appendix B, using fusion welding quality structural steel.

8.3.2 The test specimen so prepared shall be tested according to CS 122. Hardness shall be measured at points shown in Fig. 2 and the values shall be averaged.

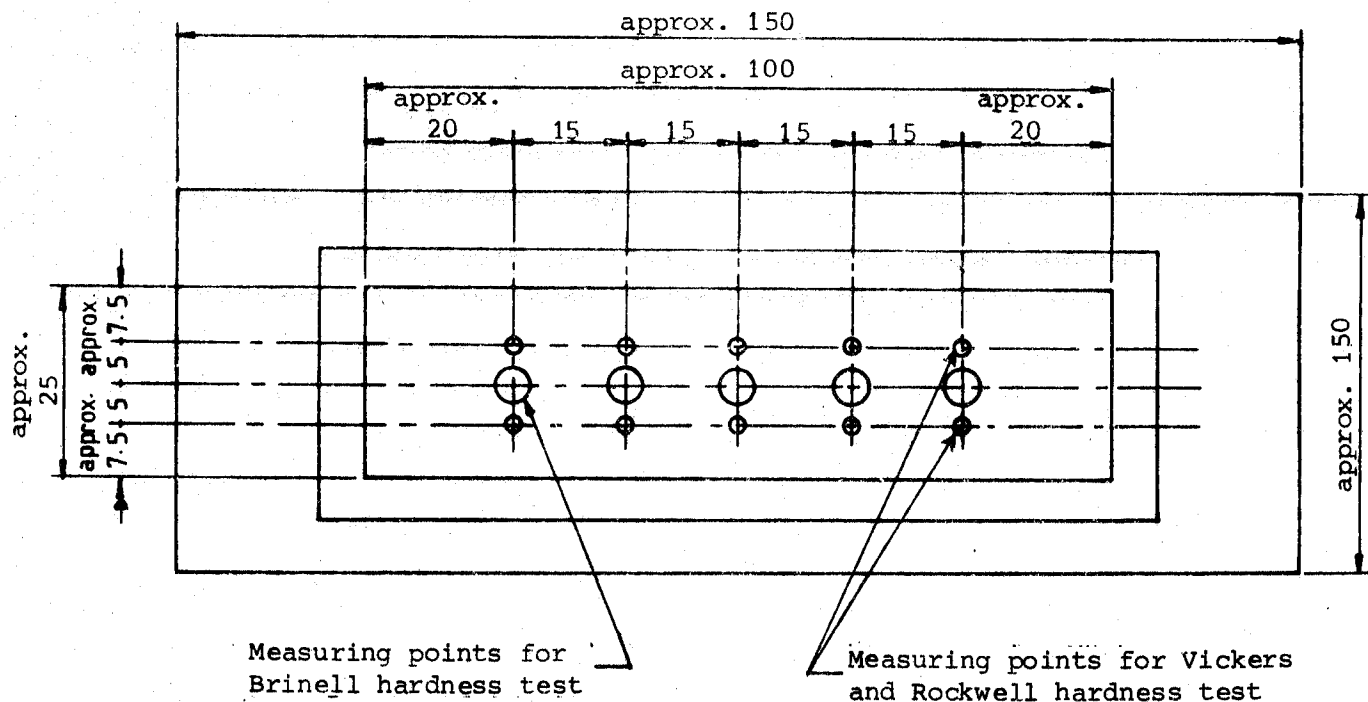

FIGURE 2 - Measuring points

All dimensions are in millimetres

9 SAMPLING

9.1 Scale of sampling

9.1.1 Lot

In any consignment all the electrodes of the same type and size manufactured by one organization under relatively similar conditions of manufacture shall be grouped together to form a lot.

9.1.2 Samples shall be tested from each lot separately for ascertaining the conformity of the electrodes to the requirements of this specification.

9.1.3 Number of packages to be selected from the lot shall be in accordance with the Columns 1 and 2 of Table 5.

TABLE 5

No. of packages in the lot	No. of packages to be selected	No. of electrodes to be selected for inspecting visually	Acceptance number
Up to 100	06	20	1
101 to 150	08	32	2
151 to 300	15	50	3
300 and above	20	80	5

9.1.4 From each package selected as above an equal number of electrodes, as far as possible shall be drawn to form a final sample of 6 kg.

9.1.5 Packages and electrodes shall be selected at random. To ensure randomness of selection, random number tables as given in SLS 428 shall be used.

9.2 Number of tests

9.2.1 Packages selected as in 9.1.3 shall be inspected for marking.

9.2.2 A sub sample of size given as in Column 3 of Table 5 shall be drawn at random from the final sample and shall be inspected visually for the requirements given in 5.2.1, 5.2.2, 5.2.3, 5.2.4 and 5.3.

9.2.3 After inspecting visually as much electrodes as required of the final sample shall be used to prepare test pads and subjected to the tests given in 5.4.3, 5.4.4, and 5.4.5.

10 CRITERIA FOR CONFORMITY

The lot shall be considered as conforming to the requirements of this specification if the following conditions are satisfied.

10.1 All the packages tested as in 9.2.1 shall satisfy the requirement.

10.2 The number of electrodes not conforming to the visual requirements is less than or equal to the corresponding acceptance number of the Column 4 of Table 5.

10.3 Test results of the test pads tested as in 9.2.3 shall satisfy the relevant requirements.

APPENDIX A

CLASSIFICATION OF HARDFACING WELDING ELECTRODES

A.1 Hardfacing electrodes are classified primarily into three classes on the basis of degree of abrasive resistance, erosion resistance and impact resistance.

A.1.1 Class 1 : Heavy abrasion resistance and negligible impact resistance.

A.1.2 Class 2 : Heavy impact resistance and negligible abrasion resistance.

A.1.3 Class 3 : Varying degree of abrasion and impact resistance. Most electrodes may be classified into this category.

A.2 Hardfacing electrodes are classified into three sub classes as follows:

A.2.1 On the basis of, chemical composition of weld deposits (see Table 1).

A.2.2 On the basis of Microstructure of weld deposits as given in Table 3.

A.2.3 On the basis of hardness of weld deposits as given in Table 5.

A.3 Following is an example for classification of hardfacing welding electrodes.

EXAMPLE :

A welding electrode which deposits weld metal with the following properties may be classified as given below:

a) Usage : Abrasion resistance

b) Microstructure : Austenitic

c) Hardness : HV 550

d) Chemical composition :

C = 0.5 - 0.9

Mn = 11.0 - 16.0

Ni = 2.75 - 6.0

Cr = 0.50

Si = 1.3

Classification :

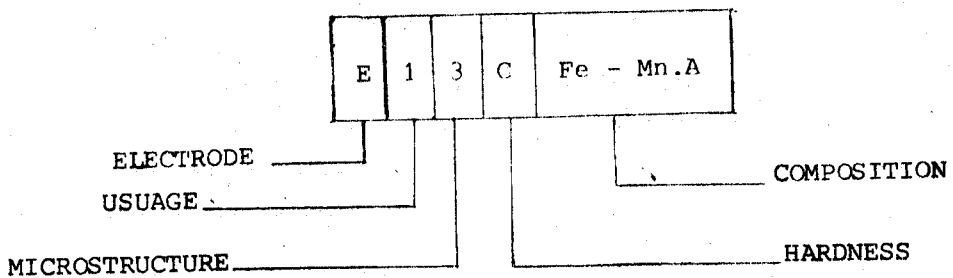

APPENDIX B

PREPARATION OF TEST PADS

B.1 Test pad for chemical analysis

B.1.1 Chemical analysis test pad shall be made as shown in Fig. 3 using fusion welding quality structural steel.

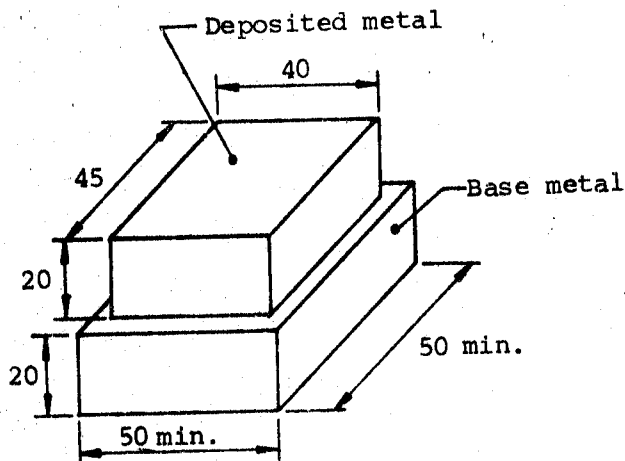

FIGURE 3 - Test pad for chemical analysis

All dimensions in millimetres

B.1.2 All surfacing on the chemical analysis test pad shall be done in the flat position.

B.1.3 The welding procedures specified by the manufacturer shall be used as to the factors not covered herein. The full length of each covered electrode shall be used, with the stub length not exceeding 40 mm.

B.2 Test pad for hardness testing of weld deposits.

B.2.1 A test pad shall be prepared as shown in Fig. 4 using fusion welding quality structural steel.

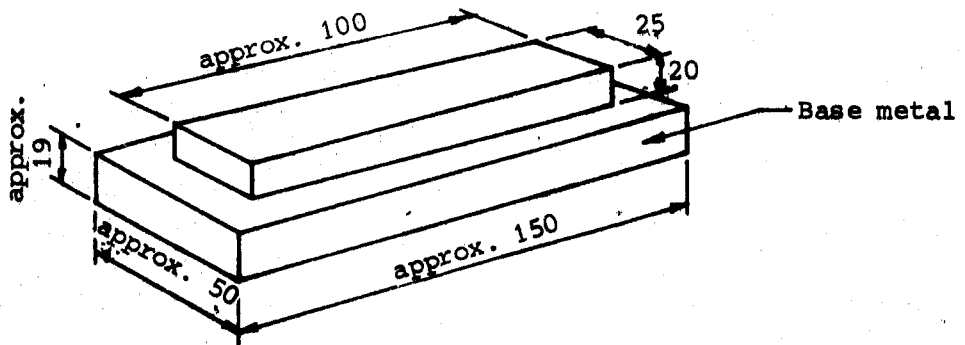

FIGURE 4 - Test pad for hardness test

B.2.2 All the welding shall be done in flat position. Care shall be taken to keep the heating of the pad to a minimum when depositing the metal.

B.2.3 Fig. 4 shows the approximate sizes of the pad and the minimum height of the deposited metal shall be 20 mm subject to minimum number of layers being six.

B.2.4 The current and voltages recommended by the manufacturer shall be used. Other welding techniques recommended by the manufacturers shall be used as to the factors not covered herein.

B.2.5 The surface of the test specimen shall be ground and polished. This operation shall be done carefully so that the maximum temperature of the specimen shall not exceed 100°C.

SLS CERTIFICATION MARK

The Sri Lanka Standards Institution is the owner of the registered certification mark shown below. Beneath the mark, the number of the Sri Lanka Standard relevant to the product is indicated. This mark may be used only by those who have obtained permits under the SLS certification marks scheme. The presence of this mark on or in relation to a product conveys the assurance that they have been produced to comply with the requirements of the relevant Sri Lanka Standard under a well designed system of quality control inspection and testing operated by the manufacturer and supervised by the SLSI which includes surveillance inspection of the factory, testing of both factory and market samples.

Further particulars of the terms and conditions of the permit may be obtained from the Sri Lanka Standards Institution, 17, Victoria Place, Elvitigala Mawatha, Colombo 08.



SRI LANKA STANDARDS INSTITUTION

The Sri Lanka Standards Institution (SLSI) is the National Standards Organization of Sri Lanka established under the Sri Lanka Standards Institution Act No. 6 of 1984 which repealed and replaced the Bureau of Ceylon Standards Act No. 38 of 1964. The Institution functions under the Ministry of Science & Technology.

The principal objects of the Institution as set out in the Act are to prepare standards and promote their adoption, to provide facilities for examination and testing of products, to operate a Certification Marks Scheme, to certify the quality of products meant for local consumption or exports and to promote standardization and quality control by educational, consultancy and research activity.

The Institution is financed by Government grants, and by the income from the sale of its publications and other services offered for Industry and Business Sector. Financial and administrative control is vested in a Council appointed in accordance with the provisions of the Act.

The development and formulation of National Standards is carried out by Technical Experts and representatives of other interest groups, assisted by the permanent officers of the Institution. These Technical Committees are appointed under the purview of the Sectoral Committees which in turn are appointed by the Council. The Sectoral Committees give the final Technical approval for the Draft National Standards prior to the approval by the Council of the SLSI.

All members of the Technical and Sectoral Committees render their services in an honorary capacity. In this process the Institution endeavours to ensure adequate representation of all view points.

In the International field the Institution represents Sri Lanka in the International Organization for Standardization (ISO), and participates in such fields of standardization as are of special interest to Sri Lanka.