

**SRI LANKA STANDARD 1296 : PART 2 : 2006**  
**ISO 1183-2:2004**

**METHOD OF**  
**TESTING FOR THE DETERMINATION OF**  
**THE DENSITY OF**  
**NON – CELLULAR PLASTICS**  
**PART 2 : DENSITY GRADIENT COLUMN METHOD**

**SRI LANKA STANDARDS INSTITUTION**



**METHODS OF  
TESTING FOR THE DETERMINATION OF THE DENSITY OF  
NON – CELLULAR PLASTICS  
PART 2 : DENSITY GRADIENT COLUMN METHOD**

**SLS 1296 : Part 2 : 2006  
ISO 1183-2 : 2004**

Gr. E

**SRI LANKA STANDARDS INSTITUTION  
17, Victoria Place  
Elvitigala Mawatha  
Colombo 08  
SRI LANKA.**

Sri Lanka Standards are subject to periodical revision in order to accommodate the progress made by industry. Suggestions for improvement will be recorded and brought to the notice of the Committees to which the revisions are entrusted.

This standard does not purport to include all the necessary provisions of a contract.

© SLSI 2006

All rights reserved. Unless otherwise specified, no part of this publication may be reproduced or utilized in any form or by any means, electronic or mechanical, including photocopying and microfilm, without permission in writing from the SLSI.

**SRI LANKA STANDARD**  
**METHODS OF TESTING FOR THE DETERMINATION OF THE DENSITY OF**  
**NON – CELLULAR PLASTICS**  
**PART 2 : DENSITY GRADIENT COLUMN METHOD**

**FOREWORD**

This Sri Lanka Standard was approved by the Sectoral Committee on Chemical and Polymer Technology and was authorized for adoption and publication as a Sri Lanka Standard by the Council of the Sri Lanka Standards Institution on 2006-10-25.

This Standard is identical with ISO 1183-2 : 2004 Plastics – Methods for determining the density of non cellular plastics part 2 : Density gradient column method published by the International Organization for Standardization.

The text of the International Standard has been accepted as suitable for publication, without deviation, as a Sri Lanka Standard. However, certain terminology and conventions are not identical with those used in Sri Lanka Standards. Attention is therefore drawn to the following :

**Terminology and Conventions :**

- a) Wherever the words ‘International Standard’ appear referring to a particular standard. They should be interpreted as “Sri Lanka Standard” .
- b) The comma has been used throughout as a decimal marker. In Sri Lanka Standards it is the current practice to use the full point at the base as the decimal marker.
- c) Wherever page numbers are quoted, they are ISO/IEC page numbers.

SLS 1296 Part 2 : 2006  
ISO 1183-2 : 2004

## **Cross References**

<b>International Standard</b>	<b>Corresponding Sri Lanka Standard</b>
ISO 31 – 3 Quantities & units – Part 3 mechanics.	CS 84 Basic quantities and units of the SI-Part 3 – Quantities and units of mechanics.
ISO 291 Plastics – Standard atmospheres for conditioning and testing.	SLS 374 standard atmospheric conditions for conditioning and attesting.
ISO 1183 – 1 plastics – Methods for determining the density o non-cellular plastics Part 1 : Immersion method, liquid Pyknonmeter method & Titration method.	SLS 1296-part 1 Methods of testing for the determination of the density of non – cellular plastics part 1 : Immersion method, liquid pyknometer method and titration method

---

---

**Plastics — Methods for determining the  
density of non-cellular plastics —**

Part 2:  
**Density gradient column method**

*Plastiques — Méthodes de détermination de la masse volumique des  
plastiques non alvéolaires —*

*Partie 2: Méthode de la colonne à gradient de masse volumique*



**PDF disclaimer**

This PDF file may contain embedded typefaces. In accordance with Adobe's licensing policy, this file may be printed or viewed but shall not be edited unless the typefaces which are embedded are licensed to and installed on the computer performing the editing. In downloading this file, parties accept therein the responsibility of not infringing Adobe's licensing policy. The ISO Central Secretariat accepts no liability in this area.

Adobe is a trademark of Adobe Systems Incorporated.

Details of the software products used to create this PDF file can be found in the General Info relative to the file; the PDF-creation parameters were optimized for printing. Every care has been taken to ensure that the file is suitable for use by ISO member bodies. In the unlikely event that a problem relating to it is found, please inform the Central Secretariat at the address given below.

© ISO 2004

All rights reserved. Unless otherwise specified, no part of this publication may be reproduced or utilized in any form or by any means, electronic or mechanical, including photocopying and microfilm, without permission in writing from either ISO at the address below or ISO's member body in the country of the requester.

ISO copyright office  
Case postale 56 • CH-1211 Geneva 20  
Tel. + 41 22 749 01 11  
Fax + 41 22 749 09 47  
E-mail [copyright@iso.org](mailto:copyright@iso.org)  
Web [www.iso.org](http://www.iso.org)

Published in Switzerland



## Contents

Page

Foreword.....	iv
<b>1</b> <b>Scope</b> .....	<b>1</b>
<b>2</b> <b>Normative references</b> .....	<b>1</b>
<b>3</b> <b>Terms and definitions</b> .....	<b>1</b>
<b>4</b> <b>Conditioning</b> .....	<b>2</b>
<b>5</b> <b>Method</b> .....	<b>2</b>
<b>6</b> <b>Test report</b> .....	<b>4</b>
<b>Annex A</b> (informative) <b>Liquid systems suitable for density determinations</b> .....	<b>6</b>
<b>Annex B</b> (informative) <b>Preparation of density gradient column</b> .....	<b>7</b>

## Foreword

ISO (the International Organization for Standardization) is a worldwide federation of national standards bodies (ISO member bodies). The work of preparing International Standards is normally carried out through ISO technical committees. Each member body interested in a subject for which a technical committee has been established has the right to be represented on that committee. International organizations, governmental and non-governmental, in liaison with ISO, also take part in the work. ISO collaborates closely with the International Electrotechnical Commission (IEC) on all matters of electrotechnical standardization.

International Standards are drafted in accordance with the rules given in the ISO/IEC Directives, Part 2.

The main task of technical committees is to prepare International Standards. Draft International Standards adopted by the technical committees are circulated to the member bodies for voting. Publication as an International Standard requires approval by at least 75 % of the member bodies casting a vote.

Attention is drawn to the possibility that some of the elements of this document may be the subject of patent rights. ISO shall not be held responsible for identifying any or all such patent rights.

ISO 1183-2 was prepared by Technical Committee ISO/TC 61, *Plastics*, Subcommittee SC 5, *Physical-chemical properties*.

Together with the other parts (see below), this part of ISO 1183 cancels and replaces ISO 1183:1987, which has been technically revised.

ISO 1183 consists of the following parts, under the general title *Plastics — Methods for determining the density of non-cellular plastics*:

- *Part 1: Immersion method, liquid pycnometer method and titration method*
- *Part 2: Density gradient column method*
- *Part 3: Gas pycnometer method*

# Plastics — Methods for determining the density of non-cellular plastics —

## Part 2: Density gradient column method

**WARNING** — The use of this part of ISO 1183 may involve hazardous materials, operations or equipment. This part of ISO 1183 does not purport to address all of the safety problems, if any, associated with its use. It is the responsibility of the user of this part of ISO 1183 to establish appropriate health and safety practices and to determine the applicability of any regulatory limitations prior to use.

### 1 Scope

This part of ISO 1183 specifies a gradient column method for the determination of the density of non-cellular moulded or extruded plastics in void-free form. Density gradient columns are columns containing a mixture of two liquids, the density in the column increasing uniformly from top to bottom.

**NOTE** This part of ISO 1183 is applicable to pellets as long as they are void-free. Density is frequently used to follow variations in physical structure or composition of plastic materials. Density may also be useful in assessing the uniformity of samples or specimens. Often the density of plastic materials will depend upon the choice of specimen preparation method. When this is the case, precise details of the specimen preparation method will have to be included in the appropriate material specification.

### 2 Normative references

The following referenced documents are indispensable for the application of this document. For dated references, only the edition cited applies. For undated references, the latest edition of the referenced document (including any amendments) applies.

ISO 31-3, *Quantities and units — Part 3: Mechanics*

ISO 291, *Plastics — Standard atmospheres for conditioning and testing*

ISO 1183-1:2004, *Plastics — Methods for determining the density of non-cellular plastics — Part 1: Immersion method, liquid pycnometer method and titration method*

### 3 Terms and definitions

For the purposes of this document, the following terms and definitions apply.

#### 3.1

##### density

$\rho$   
ratio of the mass  $m$  of a sample to its volume  $V$  (at the temperature  $t$ ) expressed in kg/m<sup>3</sup>, kg/dm<sup>3</sup> (g/cm<sup>3</sup>), or kg/l (g/ml)

**NOTE** The following terms, based upon ISO 31-3, are given here for clarification.

Table 1 — Density terms

Term	Symbol	Formulation	Units
Density	$\rho$	$m/V$	kg/m <sup>3</sup> kg/dm <sup>3</sup> (g/cm <sup>3</sup> ) kg/l (g/ml)
Specific volume	$v$	$V/m (= 1/\rho)$	m <sup>3</sup> /kg dm <sup>3</sup> /kg (cm <sup>3</sup> /g) l/kg (ml/g)

## 4 Conditioning

Conditioning and testing shall be in accordance with ISO 291 or the appropriate material standard. In general, conditioning specimens to constant temperature is not required, because the determination itself brings the specimen to the constant temperature of the test.

Specimens which change in density during the test to such an extent that the change is greater than the required accuracy of the density determination shall be conditioned prior to measurement in accordance with the applicable material specification. When changes in density with time or atmospheric conditions are the primary purpose of the measurements, the specimens shall be conditioned as described in the material specification and, if no material specification exists, then as agreed upon by the interested parties.

## 5 Method

### 5.1 Apparatus

**5.1.1 Density gradient column**, consisting of a suitable graduated column, not less than 40 mm in diameter, with a cover. The height of the column shall be compatible with the accuracy required. A graduation interval of 1 mm for the scale on the column is normal.

**5.1.2 Liquid bath**, capable of being thermostatically controlled to within  $\pm 0,1$  °C or  $\pm 0,5$  °C, depending on the sensitivity required (see Annex B).

**5.1.3 Calibrated glass floats**, covering the density range in which measurements are to be made and approximately evenly distributed throughout this range.

NOTE These may be purchased from an accredited source or prepared as described in 5.4.1.

**5.1.4 Balance**, accurate to 0,1 mg.

**5.1.5 Siphon or pipette assembly**, for filling the gradient column (5.1.1), as shown in Figure B.1 or B.2, or any other suitable device.

### 5.2 Immersion liquids

Required are two miscible liquids of different densities, freshly distilled in the case of pure liquids. The densities of various liquids are given in Annex A as a guide.

The liquid with which the specimen comes into contact during the measurement shall have no effect on the specimen.

Prepare the mixture of liquids as specified in 5.4.1.2.

### 5.3 Specimens

Specimens shall consist of pieces of the material cut to any convenient shape for ease of identification. The dimensions of each piece shall be chosen to permit accurate measurement of the position of the centre of the piece.

When cutting specimens from larger samples, care shall be taken to ensure that the characteristics of the material are not changed due to excessive heat generation. The surface of the specimen shall be smooth and free from cavities to minimize the entrapment of air bubbles upon immersion in the liquid, otherwise errors will be introduced.

NOTE Specimens of less than 5 mm in diameter are normally suitable.

### 5.4 Procedure

#### 5.4.1 Preparation and calibration of glass floats

**5.4.1.1** The glass floats (5.1.3) may be produced by any convenient method. They shall be approximately spherical, of diameter not greater than 5 mm and fully annealed.

**5.4.1.2** To prepare the glass floats for use, prepare a series of mixtures of about 500 ml of the two immersion liquids (5.2) covering the density range to be used in the density gradient column (5.1.1). With the floats and column at ambient temperature, place the floats carefully into these mixtures.

Adjust selected floats to match approximately the densities of the mixtures:

- a) either by rubbing the float on a glass plate covered with a thin slurry of silicon carbide of particle size less than 38  $\mu\text{m}$  (400 mesh) or another suitable abrasive;
- b) or by etching the float with hydrofluoric acid.

**5.4.1.3** Determine the exact density of each glass float calibrated as above by placing it in a mixture of two suitable liquids (5.2) in the bath (5.1.2) maintained at  $(t \pm 0,1)$  °C, where  $t$  is 23 °C or 27 °C (whichever will be used for the density gradient column). If the float sinks, add the denser of the two liquids (if the float rises, add the less dense) and stir gently to homogenize. Allow the mixture to stabilize. If the float still moves, adjust the density of the mixture again. Repeat this procedure until the float remains stationary for at least 30 min.

**5.4.1.4** For each float, determine, to the nearest 0,000 1 g/ml, the density of the solution in which the float remained in equilibrium, using the pycnometer method (method B) described in ISO 1183-1:2004 or any other suitable method. Apply the buoyancy correction described in ISO 1183-1:2004, Clause 6, if necessary. Record this density as the density of the float.

NOTE Calibrated glass floats may also be purchased from accredited manufacturers.

#### 5.4.2 Preparation of density gradient column

Methods for preparing the density gradient column are not specified in this part of ISO 1183, but examples of two methods are given in Annex B.

#### 5.4.3 Measurement of density

Wet three test specimens with the less dense of the two liquids used in the column and gently place them in the column. Allow the column and specimens to reach equilibrium, which will require 10 min or more. Films less than 0,05 mm thick require at least 1,5 h to settle. Rechecking thin-film specimens after several hours is advisable.

NOTE 1 One of the most common sources of error in the determination is air bubbles.

NOTE 2 Suitable methods for removing air bubbles from the specimens are a fine wire carefully manipulated or applying a vacuum to the column.

Old specimens can be removed without destroying the gradient by collecting them in a wire screen basket attached to a long wire. The basket is pulled up very slowly from the bottom of the column and, after cleaning, returned to the bottom of the column. It is essential that this be done at a slow enough rate (approximately 10 mm length of column per minute) in order not to disturb the density gradient. It can conveniently be done using a clock motor. After cleaning the column, recheck the calibration and replot density versus height.

#### 5.4.4 Calculations

The densities of specimens may be determined graphically or by calculation from the levels at which they settle, as follows:

##### a) Graphical method

Make a plot of float density versus float height on a chart large enough to be read accurately to within  $\pm 0,000 1 \text{ g/cm}^3$  and  $\pm 1 \text{ mm}$ . Find the height of each specimen on the chart and read off the corresponding density.

##### b) Calculation method

Calculate the density  $\rho_{s,x}$  of each specimen by interpolation, using the equation:

$$\rho_{s,x} = \rho_{F1} + \frac{(x-y) \times (\rho_{F2} - \rho_{F1})}{z-y} \quad (1)$$

where

$\rho_{F1}$  and  $\rho_{F2}$  are the densities of the two floats at the lower and higher ends, respectively, of the density range;

$x$  is the distance of the specimen above an arbitrary level;

$y$  and  $z$  are the distances above the same arbitrary level of the two floats of density  $\rho_{F1}$  and  $\rho_{F2}$ , respectively.

NOTE Method b) does not reveal calibration errors. These can only be detected by using method a), the graphical method. Method b) can be used when the calibration is known to be linear within the range being used.

If the relationship between float position and density is not linear, a second order polynomial may be used for interpolation of density.

Corrections for buoyancy, if required, can be calculated as described in ISO 1183-1:2004, Clause 6.

## 6 Test report

The test report shall include the following information:

- a) a reference to this part of ISO 1183;
- b) all details necessary for complete identification of the material tested, including the specimen preparation method and pretreatment, if applicable;
- c) the immersion liquids used;

- d) the value of the density determined for each of the three specimens and the arithmetic mean of these values;
- e) the temperature of the determination;
- f) details of any buoyancy corrections made;
- g) the date of the determination.

## Annex A (informative)

### Liquid systems suitable for density determinations

**WARNING** — Some of the following chemicals may be hazardous.

**Table A.1 — Examples of suitable liquid systems**

System	Density range g/cm <sup>3</sup>
Methanol/benzyl alcohol	0,79 to 1,05
Isopropanol/water	0,79 to 1,00
Isopropanol/diethylene glycol	0,79 to 1,11
Ethanol/water	0,79 to 1,00
Toluene/carbon tetrachloride	0,87 to 1,60
Water/aqueous solution of sodium bromide <sup>a</sup>	1,00 to 1,41
Water/aqueous solution of calcium nitrate	1,00 to 1,60
Ethanol/aqueous solution of zinc chloride <sup>b</sup>	0,79 to 1,70
Carbon tetrachloride/1,3-dibromopropane	1,60 to 1,99
1,3-Dibromopropane/ethylene bromide	1,99 to 2,18
Ethylene bromide/bromoform	2,18 to 2,89
Carbon tetrachloride/bromoform	1,60 to 2,89
Isopropanol/methylglycol acetate	0,79 to 1,00
<sup>a</sup> A density of 1,41 is equivalent to a mass fraction of about 40 % sodium bromide. <sup>b</sup> A density of 1,70 is equivalent to a mass fraction of about 67 % zinc chloride.	

The following may also be used in various mixtures:

	Density (g/cm <sup>3</sup> )
<i>n</i> -Octane	0,70
Dimethylformamide	0,94
Tetrachloroethane	1,60
Ethyl iodide	1,93
Methylene iodide	3,33



## Annex B (informative)

### Preparation of density gradient column

**B.1** Place the graduated column in the thermostatically controlled bath (5.1.2). Select a suitable combination of liquids (5.2) from the table in Annex A. When a sensitivity of 0,001 g/cm<sup>3</sup> is required, the temperature of the bath should be maintained to within  $\pm 0,5$  °C and the density range covered by the column limited to less than 0,2 g/cm<sup>3</sup> (preferably 0,1 g/cm<sup>3</sup>). When a sensitivity of 0,000 1 g/cm<sup>3</sup> is required, the temperature of the bath should be maintained to within  $\pm 0,1$  °C, and the density range limited to less than 0,02 g/cm<sup>3</sup> (preferably 0,01 g/cm<sup>3</sup>). The extreme upper and lower parts of the column should not be used, and readings should not be taken outside the calibrated zone.

Any of several methods for preparing the gradient column may be used, including the two methods given in B.2 and B.3.

**B.2 Method 1:** Assemble the apparatus as shown in Figure B.1, using two vessels of the same size and volume. Then select appropriate amounts of two suitable liquids, which have previously been carefully de-aerated by gentle heating or application of a vacuum. An effective method is with an ultrasonic cleaner.

Place a suitable amount of the less dense liquid into vessel 2 (the amount should be at least half of the total volume of liquid required in the gradient column — see Note 1) and turn on the magnetic stirrer. Adjust the stirrer speed so that the surface of the liquid does not move significantly. Place an equal amount of the denser liquid into vessel 1. Take care that no air is drawn into the liquid. Use the less dense liquid (starting liquid in vessel 2) to prime the siphon (5.1.5), which should be equipped with a capillary tip at the delivery end for flow control, then start delivery of the liquid to the gradient column. Fill the column to the uppermost graduation required (see Note 2).

Allow the density gradient column thus prepared to settle for at least 24 h.

NOTE 1 Calculate the density  $\rho_2$  of the liquid in vessel 2 using the equation:

$$\rho_2 = \rho_{\max} - \frac{2 \times (\rho_{\max} - \rho_{\min}) \times V_1}{V} \quad (2)$$

where

$\rho_{\min}$  is the lower limit of the required density range, taken to be 0,01 g/cm<sup>3</sup> lower than the density of the least dense glass float calibrated for the gradient column being used;

$\rho_{\max}$  is the upper limit of the required density range, i.e. the density of the liquid in vessel 1, taken to be 0,005 g/cm<sup>3</sup> higher than the density of the densest glass float calibrated for the gradient column being used;

$V$  is the total volume required in the gradient column;

$V_1$  is the initial volume of the liquid in vessel 1.

NOTE 2 Preparation of a suitable gradient column may require 1 h to 1,5 h or longer, depending upon the volume required in the column.

**B.3 Method 2:** Assemble the apparatus as shown in Figure B.2. This method is basically the same as method 1 except for the following points:

- a) the denser liquid is placed in vessel 2 and the less dense liquid in vessel 1;
- b) a siphon is used for delivery of the liquid from vessel 1 to vessel 2, and from vessel 2 to the column;

- c) the liquid is gently introduced at the top of the column, allowing it to flow down the inside surface of the column wall;
- d) the equation for calculating the density  $\rho_2$  is Equation (3):

$$\rho_2 = \rho_{\min} - \frac{2 \times (\rho_{\min} - \rho_{\max}) \times V_1}{V} \quad (3)$$

**B.4** Dip the clean floats in the lower density liquid and place them gently in the column. If it is observed that the floats stay grouped together and do not spread out evenly in the column, discard the mixture and repeat the filling procedure.

Alternatively, the floats may be placed in the column during filling of the column. If the floats stay grouped together and do not spread out evenly in the column, discard the mixture and repeat the filling procedure.

Use at least one float per 0,01 g/cm<sup>3</sup> of the density gradient when the density is required to be accurate to within 0,001 g/cm<sup>3</sup>. Use at least one float per 0,001 g/cm<sup>3</sup> when the density is required to be accurate to within 0,000 1 g/cm<sup>3</sup>. In any case, at least five floats should be used in order to give a reasonable calibration curve.

**B.5** Cap the column and keep it in a constant-temperature bath for 24 h to 48 h. At the end of this time, measure, to the nearest millimetre, the distance of the centre of each float from the bottom of the column and plot a curve of the densities of the floats as a function of their height.

A straight line is preferable. However, a plot with a slight curvature is acceptable. If the line shows any discontinuity or more than one point of inflection, the mixture shall be discarded and the filling procedure repeated.

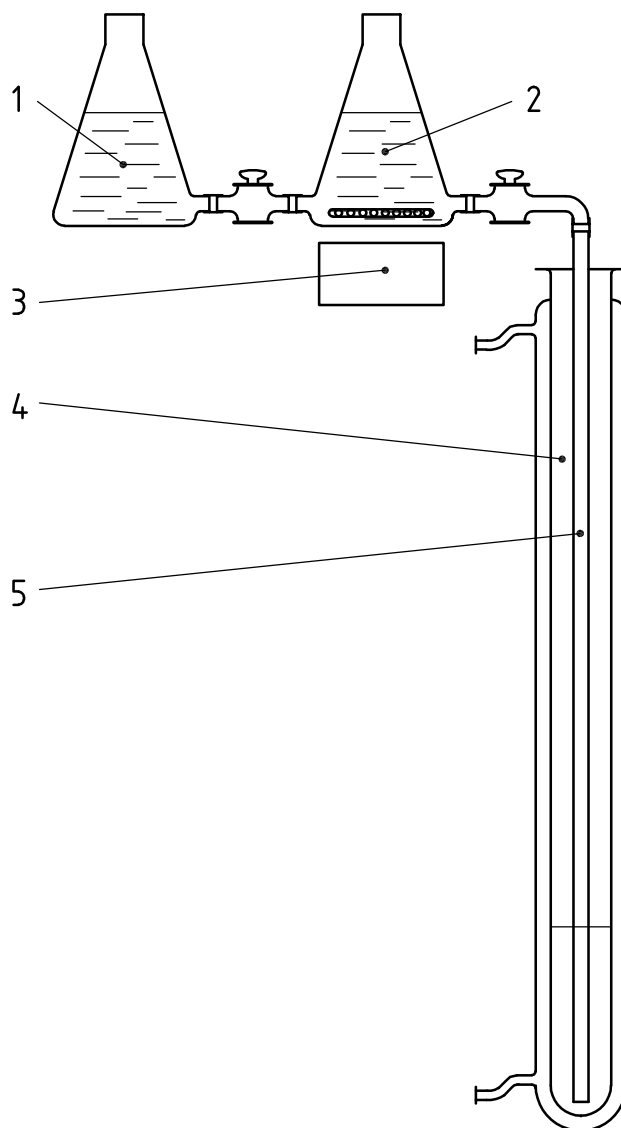
**Key**

- 1 vessel 1 (more dense liquid)
- 2 vessel 2 (less dense liquid)
- 3 magnetic stirrer
- 4 column
- 5 capillary filling tube

**Figure B.1 — Density gradient column filling apparatus for method 1**

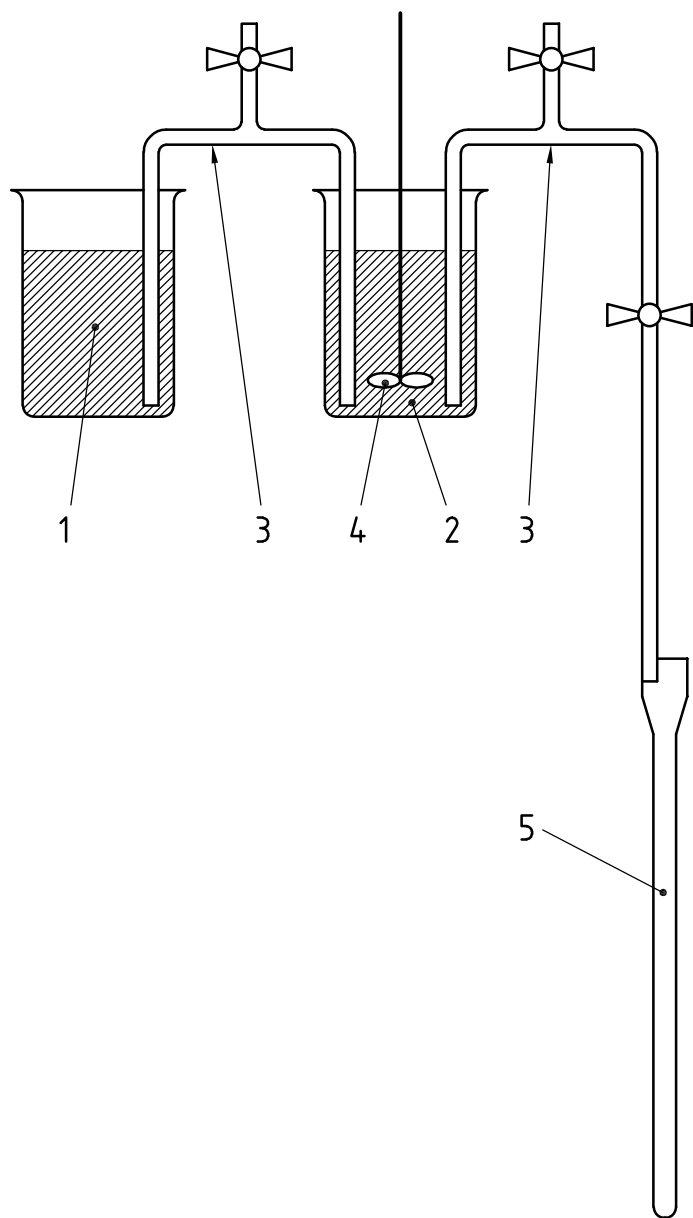

**Key**

- 1 vessel 1 (less dense liquid)
- 2 vessel 2 (more dense liquid)
- 3 siphon
- 4 stirrer
- 5 column

**Figure B.2 — Density gradient column filling apparatus for method 2**





## SRI LANKA STANDARDS INSTITUTION

The Sri Lanka Standards Institution (SLSI) is the National Standards Organization of Sri Lanka established under the Sri Lanka Standards Institution Act No. 6 of 1984 which repealed and replaced the Bureau of Ceylon Standards Act No. 38 of 1964. The Institution functions under the Ministry of Science & Technology.

The principal objects of the Institution as set out in the Act are to prepare standards and promote their adoption, to provide facilities for examination and testing of products, to operate a Certification Marks Scheme, to certify the quality of products meant for local consumption or exports and to promote standardization and quality control by educational, consultancy and research activity.

The Institution is financed by Government grants, and by the income from the sale of its publications and other services offered for Industry and Business Sector. Financial and administrative control is vested in a Council appointed in accordance with the provisions of the Act.

The development and formulation of National Standards is carried out by Technical Experts and representatives of other interest groups, assisted by the permanent officers of the Institution. These Technical Committees are appointed under the purview of the Sectoral Committees which in turn are appointed by the Council. The Sectoral Committees give the final Technical approval for the Draft National Standards prior to the approval by the Council of the SLSI.

All members of the Technical and Sectoral Committees render their services in an honorary capacity. In this process the Institution endeavours to ensure adequate representation of all view points.

In the International field the Institution represents Sri Lanka in the International Organization for Standardization (ISO), and participates in such fields of standardization as are of special interest to Sri Lanka.

## **SLS CERTIFICATION MARK**

*The Sri Lanka Standards Institution is the owner of the registered certification mark shown below. Beneath the mark, the number of the Sri Lanka Standard relevant to the product is indicated. This mark may be used only by those who have obtained permits under the SLS certification marks scheme. The presence of this mark on or in relation to a product conveys the assurance that they have been produced to comply with the requirements of the relevant Sri Lanka Standard under a well designed system of quality control inspection and testing operated by the manufacturer and supervised by the SLSI which includes surveillance inspection of the factory, testing of both factory and market samples.*

*Further particulars of the terms and conditions of the permit may be obtained from the Sri Lanka Standards Institution, 17, Victoria Place, Elvitigala Mawatha, Colombo 08.*

