

SRI LANKA STANDARD 1256 : PART 4 : 2004
ISO 1523 : 2002

METHODS OF
TEST FOR PAINTS AND VARNISHES
PART 4 : DETERMINATION OF FLASH POINT-
CLOSED CUP METHOD

SRI LANKA STANDARDS INSTITUTION



METHODS OF TEST FOR PAINTS AND VARNISHES
PART 4 : DETERMINATION OF FLASH POINT- CLOSED CUP METHOD

SLS 1256 : Part 4 : 2004
ISO 1523 : 2002
(Superceding SLS 535 Part 1 : 1981 Section 1.5)

Gr. F

SRI LANKA STANDARDS INSTITUTION
17, Victoria Place
Elvitigala Mawatha
Colombo - 08
Sri Lanka.

Sri Lanka Standards are subject to periodical revision in order to accommodate the progress made by industry. Suggestions for improvement will be recorded and brought to the notice of the Committees to which the revisions are entrusted.

This standard does not purport to include all the necessary provisions of a contract.

© SLSI 2004

All rights reserved. Unless otherwise specified, no part of this publication may be reproduced or utilized in any form or by any means, electronic or mechanical, including photocopying and microfilm, without permission in writing from the SLSI.

SRI LANKA STANDARD
METHODS OF TEST FOR PAINTS AND VARNISHES
PART 4 : DETERMINATION OF FLASH POINT- CLOSED CUP METHOD

NATIONAL FOREWORD

This Sri Lanka Standard was approved by the Sectoral Committee on Chemical and Polymer Technology and authorized for adoption and publication by the Council of the Sri Lanka Standards Institution on 2004-01-23.

This standard was published in 1981 which superceded CS 70 : 1969. In this revision each test method is given as a separate part in order to facilitate updating. This standard supercedes SLS 535 : Part 1 : 1981. Tests on liquid paints (excluding chemical tests). Section 1.5 Determination of flash point-Closed cup method.

TERMINOLOGY AND CONVENTIONS

The text of the International Standard has been accepted as suitable for publication without deviation, as a Sri Lanka Standard. However certain terminology and conventions are not identical with those used in Sri Lanka Standards. Attention is therefore drawn to the following :

- a) Wherever the words ‘International Standard/publication’ appear referring to a particular standard, they should be interpreted as “Sri Lanka Standard” .
- b) The comma has been used throughout as a decimal marker. In Sri Lanka Standards it is the current practice to use the full point on the baseline as the decimal marker.

Attention is also drawn to the test temperature adopted in Sri Lanka which is 27 ± 0.5 °C.

SLS 1256 : Part 4 : 2004
ISO 1523 : 2002
(Superceding SLS 535:1981 Part 1- Section 1.5)

CROSS REFERENCES

International Standard

Corresponding Sri Lanka Standard

ISO 1513 Paints and varnishes- Examination and preparation of samples for testing

SLS 1256 : Part 1– Methods of tests for paints and varnishes – Examination and preparation of samples for testing

ISO 1516 Paints and varnishes – Determination of the danger classification by flash point - Closed cup method

No equivalent Sri Lanka Standard

ISO 15228 Paints and varnishes – Sampling

SLS 523 Methods of sampling paints

INTERNATIONAL
STANDARD

ISO
1523

Third edition
2002-03-01

**Determination of flash point — Closed cup
equilibrium method**

Détermination du point d'éclair — Méthode à l'équilibre en vase clos



Reference number
ISO 1523:2002(E)

© ISO 2002

PDF disclaimer

This PDF file may contain embedded typefaces. In accordance with Adobe's licensing policy, this file may be printed or viewed but shall not be edited unless the typefaces which are embedded are licensed to and installed on the computer performing the editing. In downloading this file, parties accept therein the responsibility of not infringing Adobe's licensing policy. The ISO Central Secretariat accepts no liability in this area.

Adobe is a trademark of Adobe Systems Incorporated.

Details of the software products used to create this PDF file can be found in the General Info relative to the file; the PDF-creation parameters were optimized for printing. Every care has been taken to ensure that the file is suitable for use by ISO member bodies. In the unlikely event that a problem relating to it is found, please inform the Central Secretariat at the address given below.

© ISO 2002

All rights reserved. Unless otherwise specified, no part of this publication may be reproduced or utilized in any form or by any means, electronic or mechanical, including photocopying and microfilm, without permission in writing from either ISO at the address below or ISO's member body in the country of the requester.

ISO copyright office
Case postale 56 • CH-1211 Geneva 20
Tel. + 41 22 749 01 11
Fax + 41 22 749 09 47
E-mail copyright@iso.ch
Web www.iso.ch

Printed in Switzerland

Contents

Page

Foreword.....	iv
Introduction.....	v
1 Scope	1
2 Normative references	1
3 Term and definition	2
4 Principle.....	2
5 Chemicals and materials.....	2
6 Apparatus	2
7 Apparatus preparation	3
8 Sampling.....	4
9 Sample handling	5
10 Procedure	5
11 Calculation	6
12 Expression of result	7
13 Precision.....	7
14 Test report	7
Annex A (informative) Verification of apparatus.....	8
Bibliography.....	11

Foreword

ISO (the International Organization for Standardization) is a worldwide federation of national standards bodies (ISO member bodies). The work of preparing International Standards is normally carried out through ISO technical committees. Each member body interested in a subject for which a technical committee has been established has the right to be represented on that committee. International organizations, governmental and non-governmental, in liaison with ISO, also take part in the work. ISO collaborates closely with the International Electrotechnical Commission (IEC) on all matters of electrotechnical standardization.

International Standards are drafted in accordance with the rules given in the ISO/IEC Directives, Part 3.

The main task of technical committees is to prepare International Standards. Draft International Standards adopted by the technical committees are circulated to the member bodies for voting. Publication as an International Standard requires approval by at least 75 % of the member bodies casting a vote.

Attention is drawn to the possibility that some of the elements of this International Standard may be the subject of patent rights. ISO shall not be held responsible for identifying any or all such patent rights.

ISO 1523 was prepared jointly by Technical Committees ISO/TC 28, *Petroleum products and lubricants* and ISO/TC 35, *Paints and varnishes*.

This third edition cancels and replaces the second edition (ISO 1523:1983), which has been technically revised.

Annex A of this International Standard is for information only.

Introduction

This International Standard describes one of two closed cup equilibrium methods for the determination of the flash point of paints, varnishes, petroleum and related products, and it should be read in conjunction with the second equilibrium method, ISO 3679 ([5] in the bibliography), when selecting a method.

The determination of the flash/no flash temperature using the same equipment is described in ISO 1516 ([4] in the bibliography).

By the procedure specified, differences between test apparatus of various standard designs are minimized by ensuring that the test is carried out only when the product under test and the air/vapour mixture above it in the test vessel are considered to be in temperature equilibrium.

Determination of flash point — Closed cup equilibrium method

WARNING — The use of this International Standard may involve hazardous materials, operations and equipment. This International Standard does not purport to address all of the safety problems associated with its use. It is the responsibility of the user of this International Standard to establish appropriate safety and health practices and determine the applicability of regulatory limitations prior to use.

1 Scope

This International Standard specifies a method to determine the flash point of paints, varnishes, paint binders, solvents, petroleum or related products.

This International Standard is not applicable to water-borne paints which may, however, be tested using ISO 3679 ([5] in the bibliography).

The method is suitable for use over the temperature range $-30\text{ }^{\circ}\text{C}$ to $110\text{ }^{\circ}\text{C}$, depending on the use of different apparatus listed in Table 1.

The interpretation of results obtained from solvent mixtures containing halogenated hydrocarbons should be considered with caution, as these mixtures can give anomalous results.

2 Normative references

The following normative documents contain provisions which, through reference in this text, constitute provisions of this International Standard. For dated references, subsequent amendments to, or revisions of, any of these publications do not apply. However, parties to agreements based on this International Standard are encouraged to investigate the possibility of applying the most recent editions of the normative documents indicated below. For undated references, the latest edition of the normative document referred to applies. Members of ISO and IEC maintain registers of currently valid International Standards.

ISO 1513:1992, *Paints and varnishes — Examination and preparation of samples for testing*

ISO 2719:—¹⁾, *Petroleum products and lubricants — Determination of flash point — Pensky-Martens closed cup method*

ISO 3170:1988, *Petroleum liquids — Manual sampling*

ISO 3171:1988, *Petroleum liquids — Automatic pipeline sampling*

ISO 13736:1997, *Petroleum products and other liquids — Determination of flash point — Abel closed cup method*

ISO 15528:2000, *Paints, varnishes and raw materials for paints and varnishes — Sampling*

ASTM D56-00, *Standard Test Method for Flash Point by Tag Closed Tester*

DIN 51755:1974, *Testing of mineral oils and other combustible liquids; determination of flash point by the closed tester according to Abel-Pensky*

1) To be published. (Revision of ISO 2719:1988)

3 Term and definition

For the purposes of this International Standard, wherein ignition source is recognized as being a flame, the following term and definition apply.

3.1

flash point

lowest temperature of the test portion, corrected to a barometric pressure of 101,3 kPa, at which application of an ignition source causes the vapour of the test portion to ignite and the flame to propagate across the surface of the liquid under the specified conditions of test

4 Principle

The test portion is placed in a suitably designed closed cup mounted in a heating bath. The temperature of the bath is slowly raised at such a rate that the difference in temperature between the liquid in the bath and the test portion in the cup never exceeds 2 °C, and the temperature of the test portion does not rise at a rate greater than approximately 0,5 °C in 1,5 min.

During the heating-up period, ignition trials are carried out at intervals of not less than 1,5 min. The lowest temperature at which a flash occurs is noted.

5 Chemicals and materials

5.1 Cleaning solvent, for removal of traces of the previous test portion from the test cup and cover.

NOTE The choice of solvent will depend upon the previous material tested, and the tenacity of the residue. Low volatility aromatic (benzene-free) solvents may be used to remove traces of oil, and mixed solvents such as toluene-acetone-methanol may be effective for the removal of gum-type deposits.

5.2 Verification liquids, see annex A.

6 Apparatus

6.1 Test cup and lid: a closed cup with, where specified, an internal level indicator, and lid, as specified in the standards listed in Table 1.

The test cup shall be fitted with a tightly fitting cover which carries an opening slide and an ignition device capable, when the slide is open, of positioning an ignition flame, with a diameter of between 3 mm and 4 mm, at the approximate centre of the opening in the lid. When positioned, the tip of the ignition device shall be between the planes of the lower and upper surfaces of the lid at a point on a radius passing through the centre of the opening. The apparatus shall be designed such that an ignition trial can be performed by opening the slide, positioning and removing the nozzle of the ignition device, and closing the slide again in a period of between 2 s and 3 s. A mechanically driven device for carrying out this operation is permitted provided that it can be shown that it meets the specification.

NOTE The source of flame in the ignition device may be any suitable flammable gas.

6.2 Test cup thermometer, as specified for use with the test cup in the standards listed in Table 1.

NOTE Other types of temperature measuring devices may be used provided that they meet the requirements for accuracy and have the same response as the thermometers specified in the standards listed in Table 1.

6.3 Heating bath, containing a suitable liquid, capable of being heated at the required temperature rate (see 10.10), and of adequate size and heat capacity to meet the requirements of 10.10.

Table 1 — Applicable temperature range

Standard test method	Temperature range °C
ISO 2719 Pensky-Martens	10 to 110
ISO 13736 Abel	– 30 to 80
ASTM D56 Tag	Up to 93
DIN 51755 Abel-Pensky	– 30 to 65

6.4 Heating bath thermometer, capable of measuring the test temperature with the same accuracy as that of the test cup thermometer (6.2).

6.5 Support, designed such that the test cup is immersed in direct contact with the liquid in the heating/cooling bath, in such a position that the level of the test portion in the cup is the same as that of the liquid and that the cover and upper edge are horizontal. For an example, see Figure 1, which illustrates the use of the Abel test cup.

6.6 Barometer, accurate to 0,1 kPa. Barometers precorrected to give sea-level readings, such as those used at weather stations and airports, shall not be used.

6.7 Heating bath or oven (if required), capable of meeting the requirements for the pretreatment of samples that are semi-solid or solid at ambient temperature. See 9.1.4.

6.8 Cooling bath or refrigeration unit (if required), capable of cooling the sample to at least 10 °C below the test temperature. See 9.3.

7 Apparatus preparation

7.1 Location of the apparatus

Set up the apparatus in a draught-free position and preferably in subdued light.

7.2 Preparation of the heating bath

Bring the temperature of the heating bath (6.3) to a temperature 5 °C below the expected flash point (see the last paragraph of 10.1).

7.3 Preparation of the test cup

Carefully clean and dry the test cup (6.1), its cover, thermometer (6.2) and where appropriate, the stirrer. Bring them to a temperature at least 5 °C below the expected flash point (see the last paragraph of 10.1).

7.4 Apparatus verification

7.4.1 Verify the correct functioning of the apparatus at least once a year by testing a certified reference material (CRM) (A.2.1). The result obtained shall be equal to or less than $R/\sqrt{2}$ from the certified value of the CRM, where R is the reproducibility of the method (see 13.2).

It is recommended that more frequent verification checks be made using secondary working standards (SWSs) (A.2.2).

NOTE A recommended procedure for apparatus verification using CRMs and SWSs, and the production of SWSs, is given in annex A.

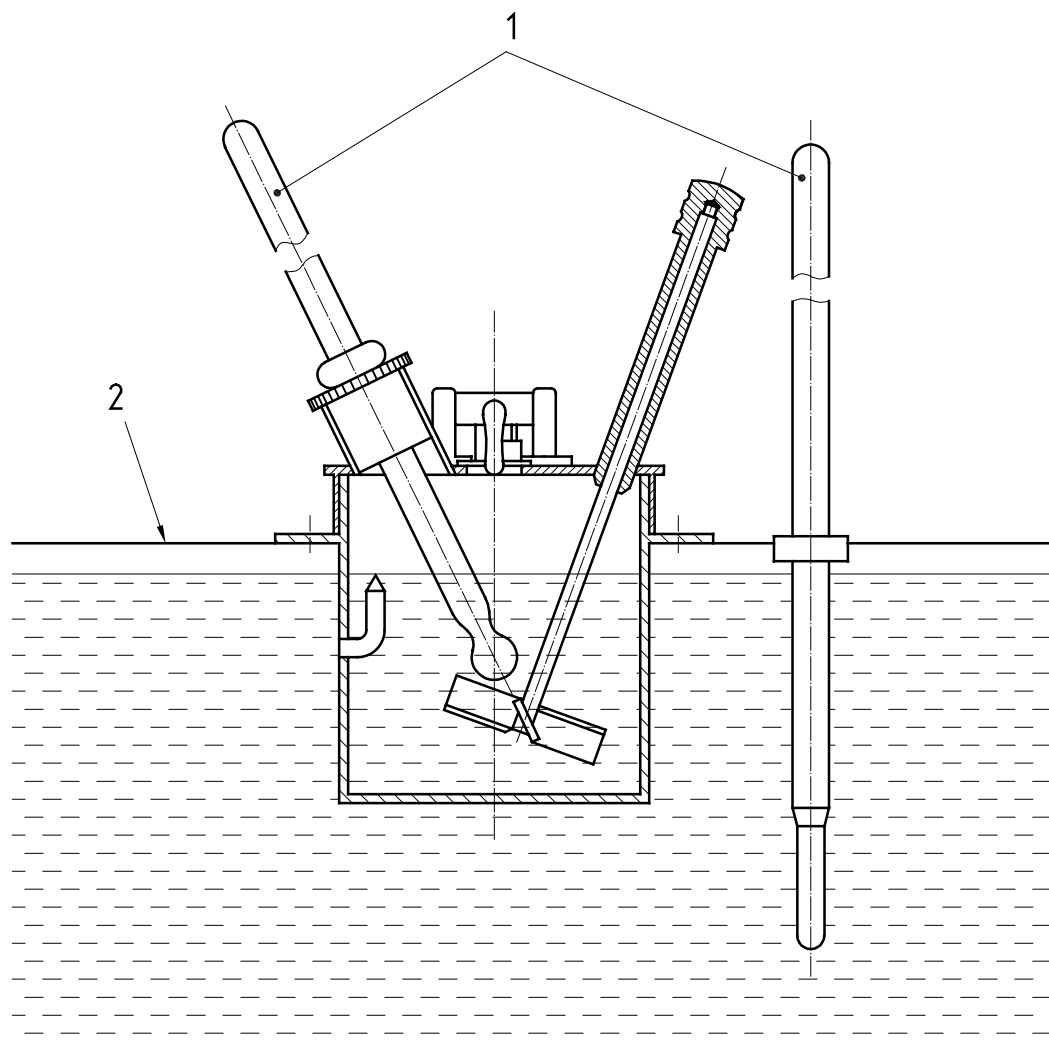

Key

- 1 Thermometers
- 2 Support

NOTE The stirrer for the heating bath is not shown.

Figure 1 — Abel closed cup, with fitted stirrer, correctly positioned in the heating bath

7.4.2 The numerical values obtained during the verification check shall not be used to provide a bias statement, nor shall they be used to make any correction to the flash points subsequently determined using the apparatus.

8 Sampling

8.1 Unless otherwise specified, obtain samples for analysis in accordance with the procedures given in ISO 15528, ISO 3170, ISO 3171 or an equivalent National Standard.

8.2 Place samples in tightly sealed containers, appropriate to the material being sampled. **For safety purposes, ensure that the sample container is only filled to between 85 % and 95 % of its capacity.**

8.3 Store the samples in conditions to minimize vapour loss and pressure build-up. Avoid storing the samples at temperatures in excess of 30 °C.

9 Sample handling

9.1 Petroleum products

9.1.1 Subsampling

If an aliquot of the original sample is to be stored prior to testing, ensure that the container is filled to at least 50 % of its capacity.

NOTE Results of flash point determinations may be affected if the sample volume falls below 50 % of the container capacity.

9.1.2 Samples containing undissolved water

If a sample contains undissolved water, decant an aliquot from the water prior to mixing.

Flash point results can be affected by the presence of water. For certain fuel oils and lubricants, it may not always be possible to decant the sample from the free water. In such cases, the water should be separated from the aliquot physically, prior to mixing, or, if this is not possible, the material should be tested according to ISO 3679 ([5] in the bibliography).

9.1.3 Samples that are liquid at ambient temperature

Mix samples by gently shaking by hand prior to the removal of the test portion, taking care to minimize the loss of volatile components, and proceed in accordance with clause 10.

9.1.4 Samples that are semi-solid or solid at ambient temperature

Heat the sample in its container in a heating bath or oven (6.7) at a temperature of $30\text{ °C} \pm 5\text{ °C}$ or a higher temperature not exceeding 28 °C below the expected flash point, whichever is the greater, for 30 min. If after 30 min the sample is still not completely liquefied, extend the preheating for further 30 min periods as required. Avoid overheating the sample, as this could lead to loss of volatile components. After gentle agitation, proceed in accordance with clause 10.

9.2 Paints and varnishes

Prepare the samples in accordance with ISO 1513.

9.3 Samples to be tested at a temperature below ambient

Cool the sample in a cooling bath or refrigeration unit (6.8) to at least 10 °C below the initial test temperature.

10 Procedure

10.1 Measure and record the ambient barometric pressure using a barometer (6.6) in the vicinity of the apparatus at the time of test.

NOTE It is not considered necessary to correct the barometric pressure to 0 °C , although some barometers are designed to make this correction automatically.

When testing a material of unknown flash point, a preliminary test should be carried out to determine the approximate flash point of the sample. A non-equilibrium technique using the same type of flash point apparatus may be used for this purpose.

10.2 Fill the test cup (6.1) with the test portion either until the internal level indicator just disappears under the surface of the liquid, or with the required volume of test portion (see the note below). Take care to avoid both the

ISO 1523:2002(E)

formation of bubbles and contact between the test portion and the test cup wall above the level indicator. If either of these conditions occurs to a significant extent, empty the test cup, and prepare it again in accordance with 7.3 before refilling it with a fresh test portion.

NOTE For the Tag closed tester, 50 ml \pm 0,5 ml are used for the test.

10.3 Immediately after filling the test cup, place the cover and thermometer (6.2) in position. Support the test cup in the bath (6.3) so that the cover is horizontal and the test cup is immersed in direct contact with the liquid in the bath, and with the surface of the test portion at the same level as that of the liquid in the bath. For an example, see Figure 1, which illustrates the use of the Abel test cup.

10.4 Light the flame of the ignition device and adjust it to an approximately spherical shape with a diameter of between 3 mm and 4 mm.

10.5 If the apparatus is fitted with a stirrer, use it in accordance with the procedure given in the test method appropriate to the test cup being used.

10.6 As soon as the test portion has attained the same temperature as the liquid in the bath, where appropriate, cease stirring the test portion. Carry out an ignition trial by opening the slide, lowering and raising the ignition device, and closing the slide again, over a period of between 2 s and 3 s. Note whether or not a flash occurs.

10.7 If a flash occurs, repeat the procedure given in 10.2 to 10.5 using a fresh test portion, but starting the test at a temperature 5 °C lower than that selected previously.

10.8 If the vapour mixture under test is near the flash point, application of the ignition flame may give rise to a halo; however, the product is only deemed to have flashed if a comparatively large blue flame appears and propagates itself over the surface of the liquid.

10.9 If a continuous luminous flame burns in the orifice when the slide is opened and the ignition flame is introduced, the flash point of the product lies considerably below the test temperature. Repeat the test, reducing the starting temperature by 10 °C, or establish the starting temperature by carrying out a preliminary test (see the last paragraph of 10.1).

10.10 If no flash occurs, increase the heating rate of the bath such that the difference in temperature between the bath and the test portion never exceeds 2 °C. When the test portion has increased in temperature by 0,5 °C (i.e. after not less than 1,5 min), repeat the ignition test and, if no flash is observed, repeat the procedure until a temperature is reached at which a flash occurs (see 10.8). Read the temperature indicated by the test cup thermometer, to the nearest 0,5 °C, correct this reading for any known thermometer correction, and record the result as the flash point at the atmospheric pressure prevailing during the test.

NOTE 1 To ensure that the test is carried out under approximately equilibrium conditions, a slow rate of heating is necessary because of the low thermal conductivity of some products and also because heat transfer by convection is hindered by the high viscosity of many products. Uniformity of temperature throughout the product under test may be assisted by use of a stirring device, if fitted to the apparatus, although it is not to be operated during an ignition trial.

NOTE 2 A minimum time interval of 1,5 min is necessary to ensure that the vapour-liquid system has stabilized.

As volatile components are likely to be lost from the test portion, the total duration of the test on any one test portion should not exceed 1 h.

11 Calculation

11.1 If the barometric pressure reading is measured in a unit other than kilopascals, convert to kilopascals using one of the following equations:

$$\text{Reading in hPa} \times 0,1 = \text{kPa}$$

$$\text{Reading in mbar} \times 0,1 = \text{kPa}$$

$$\text{Reading in mmHg} \times 0,133\ 3 = \text{kPa}$$

11.2 Calculate the flash point, in degrees Celsius, corrected to standard atmospheric pressure of 101,3 kPa, T_c , using the following equation.

$$T_c = T_o + 0,25(101,3 - p)$$

where

T_o is the observed flash point at ambient barometric pressure, expressed in degrees Celsius;

p is the ambient barometric pressure, expressed in kilopascals.

NOTE This equation is strictly correct only within the barometric pressure range from 98,0 kPa to 104,7 kPa.

12 Expression of result

Report the flash point, in degrees Celsius, corrected to standard atmospheric pressure, rounded to the nearest 0,5 °C.

13 Precision

13.1 Repeatability, r

The difference between two test results obtained by the same operator with the same apparatus under constant operating conditions on identical test material would in the long run, in the normal and correct operation of the test method, exceed the value given below in only one case in twenty:

$$r = 2 \text{ °C}$$

13.2 Reproducibility, R

The difference between two single and independent test results obtained by different operators working in different laboratories on identical test material would in the long run, in the normal and correct operation of the test method, exceed the value given below in only one case in twenty:

$$R = 3 \text{ °C}$$

14 Test report

The test report shall include at least the following information:

- a) a reference to this International Standard;
- b) the type and complete identification of the sample tested;
- c) a reference to the standard describing the test cup used (see Table 1);
- d) the ambient barometric pressure in the vicinity of the apparatus at the time of the test (see 10.1);
- e) the flash point, corrected to standard atmospheric pressure, in degrees Celsius (see clause 12);
- f) any deviation, by agreement or otherwise, from the procedure specified;
- g) the date of the test.

Annex A (informative)

Verification of apparatus

A.1 General

This annex describes a procedure for producing a secondary working standard (SWS) and conducting verification checks using a SWS and a certified reference material (CRM).

The performance of the apparatus (manual or automated) should be verified on a regular basis using either a CRM produced in accordance with ISO Guide 34 ([2] in the bibliography) and ISO Guide 35 [3], or an in-house reference material/SWS prepared in accordance with one of the procedures given in A.2.2. The performance of the apparatus should be assessed in accordance with the guidance given in ISO Guide 33 [1] and ISO 4259 [6].

The evaluation of the test result assumes a 95 % confidence limit for the trueness of the result.

A.2 Verification check standards

A.2.1 Certified reference material (CRM), comprising a stable single hydrocarbon or other stable substance with a flash point determined in accordance with ISO Guide 34 and ISO Guide 35, using a method-specific inter-laboratory study to produce a method-specific certified value.

A.2.2 Secondary working standard (SWS), comprising a stable petroleum product or a single hydrocarbon or other stable substance with a flash point determined either by

- a) testing representative subsamples at least three times using an instrument previously verified using a CRM, statistically analysing the results and, after the removal of any outliers, calculating the arithmetic mean of the results, or
- b) conducting an interlaboratory method-specific test programme utilizing at least three laboratories testing representative samples in duplicate. The assigned value of the flash point should be calculated after statistically analysing the interlaboratory data.

Store SWSs in containers which will retain the integrity of the SWS, out of direct sunlight, at a temperature not exceeding 10 °C.

A.3 Procedure

A.3.1 Chose a CRM or SWS which falls within the range of flash points to be determined with the apparatus. See Table A.1 for approximate flash point values.

It is recommended that two CRMs or SWSs be used in order to cover as wide a range as possible. In addition, it is also recommended that replicate tests are carried out on aliquots of the CRM or SWS.

A.3.2 For new apparatus, and at least once a year for working apparatus, conduct a verification check using a CRM (A.2.1) tested in accordance with 7.4.

Table A.1 — Approximate closed cup flash points of hydrocarbons and other chemicals

Substance	Nominal flash point
	°C
2,2,4-Trimethylpentane	-9
Toluene	6
Octane	14
1,4-Dimethylbenzene	26
Nonane	32
Cyclohexanone	43
Decane	49
Hexan-1-ol	60
Undecane	63
Dodecane	84
Tetradecane	109
Nonan-1-ol	109

A.3.3 For intermediate verification, conduct a verification check using a SWS (A.2.2) tested in accordance with clause 10.

A.3.4 Correct the result for barometric pressure in accordance with clause 11. Record the corrected result, to the nearest 0,1 °C, in a permanent record.

A.4 Evaluation of test result

A.4.1 General

Compare the corrected test result(s) with the certified value of the CRM or the assigned value of the SWS.

In the equations given in A.4.1.1 and A.4.1.2, it is assumed that reproducibility has been estimated in accordance with ISO 4259 and that the certified value of the CRM, or the assigned value of the SWS, has been obtained by the procedures set out in ISO Guide 35. It is also assumed that its uncertainty is small in comparison with the standard deviation of the test method and thus small compared with the reproducibility of the test method, R .

A.4.1.1 Single test

For a single test made on a CRM or SWS, the difference between a single result and the certified value of the CRM or the assigned value of the SWS should be within the following tolerance:

$$|x - \mu| \leq \frac{R}{\sqrt{2}}$$

where

x is the result of the test;

μ is the certified value of the CRM or the assigned value of the SWS;

R is the reproducibility of the test method.

A.4.1.2 Multiple tests

If a number of replicate tests, n , are made on a CRM or SWS, the difference between the mean of the n results and the certified value of the CRM or the assigned value of the SWS, should be within the following tolerance:

$$|\bar{x} - \mu| \leq \frac{R_1}{\sqrt{2}}$$

where

\bar{x} is the mean of the test results;

μ is the certified value of the CRM or the assigned value of the SWS;

R_1 is equal to $\sqrt{R^2 - r^2 [1 - (1/n)]}$;

R is the reproducibility of the test method;

r is the repeatability of the test method;

n is the number of replicate tests carried out on the CRM or SWS.

A.4.2 If the test result conforms with the tolerance requirements, record this fact.

A.4.3 If the result does not conform to the tolerance requirements and a SWS has been used for the verification check, repeat using a CRM. If the result conforms with the tolerance requirements, record this fact and dispose of the SWS.

A.4.4 If the test result still does not conform to the tolerance requirements, examine the apparatus and check that it conforms with the apparatus specification requirements. If there is no obvious nonconformity, conduct a further verification check using a different CRM. If the result conforms to the tolerance requirements, record this fact. If it is still not within the required tolerances, send the apparatus to the manufacturer for a detailed examination.

Bibliography

- [1] ISO Guide 33:2000, *Uses of certified reference materials*
- [2] ISO Guide 34:2000, *General requirements for the competence of reference material producers*
- [3] ISO Guide 35:1989, *Certification of reference materials — General and statistical principles*
- [4] ISO 1516:2002, *Determination of flash/no flash — Closed cup equilibrium method*
- [5] ISO 3679:—²), *Determination of flash point — Rapid equilibrium closed cup method*
- [6] ISO 4259:1992, *Petroleum products — Determination and application of precision data in relation to methods of test*

2) To be published. (Revision of ISO 3679:1983)

SLS 1256-4:2004

ISO 1523:2002(E)

ICS 75.080; 87.040

Price based on 11 pages

© ISO 2002 – All rights reserved

SRI LANKA STANDARDS INSTITUTION

The Sri Lanka Standards Institution (SLSI) is the National Standards Organization of Sri Lanka established under the Sri Lanka Standards Institution Act No. 6 of 1984 which repealed and replaced the Bureau of Ceylon Standards Act No. 38 of 1964. The Institution functions under the Ministry of Science & Technology.

The principal objects of the Institution as set out in the Act are to prepare standards and promote their adoption, to provide facilities for examination and testing of products, to operate a Certification Marks Scheme, to certify the quality of products meant for local consumption or exports and to promote standardization and quality control by educational, consultancy and research activity.

The Institution is financed by Government grants, and by the income from the sale of its publications and other services offered for Industry and Business Sector. Financial and administrative control is vested in a Council appointed in accordance with the provisions of the Act.

The development and formulation of National Standards is carried out by Technical Experts and representatives of other interest groups, assisted by the permanent officers of the Institution. These Technical Committees are appointed under the purview of the Sectoral Committees which in turn are appointed by the Council. The Sectoral Committees give the final Technical approval for the Draft National Standards prior to the approval by the Council of the SLSI.

All members of the Technical and Sectoral Committees render their services in an honorary capacity. In this process the Institution endeavours to ensure adequate representation of all view points.

In the International field the Institution represents Sri Lanka in the International Organization for Standardization (ISO), and participates in such fields of standardization as are of special interest to Sri Lanka.

SLS CERTIFICATION MARK

The Sri Lanka Standards Institution is the owner of the registered certification mark shown below. Beneath the mark, the number of the Sri Lanka Standard relevant to the product is indicated. This mark may be used only by those who have obtained permits under the SLS certification marks scheme. The presence of this mark on or in relation to a product conveys the assurance that they have been produced to comply with the requirements of the relevant Sri Lanka Standard under a well designed system of quality control inspection and testing operated by the manufacturer and supervised by the SLSI which includes surveillance inspection of the factory, testing of both factory and market samples.

Further particulars of the terms and conditions of the permit may be obtained from the Sri Lanka Standards Institution, 17, Victoria Place, Elvitigala Mawatha, Colombo 08.

