

**SRI LANKA STANDARD 1025 PART 4: 2022**  
**(IEC 60851-4: 2016)**

**METHODS OF TEST FOR WINDING WIRES**  
**PART 4: CHEMICAL PROPERTIES**  
*(Second Revision)*

**SRI LANKA STANDARDS INSTITUTION**



**Sri Lanka Standard**  
**METHODS OF TEST FOR WINDING WIRES PART 4: CHEMICAL PROPERTIES**  
*(Second Revision)*

**SLS 1025 Part 4: 2022**  
**(IEC 60851-4: 2016)**

**Gr. K**

*Copyright Reserved*  
**SRI LANKA STANDARDS INSTITUTION**  
**No. 17, Victoria Place,**  
**Elvitigala Mawatha,**  
**Colombo 08.**  
**SRI LANKA**

Sri Lanka Standards are subject to periodical revision in order to accommodate the progress made by industry. Suggestions for improvement will be recorded and brought to the notice of the Committees to which the revisions are entrusted.

This Standard does not purport to include all the necessary provisions of a contract

© SLSI 2022

All right reserved. Unless otherwise specified, no part of this publication may be reproduced or utilized in any form or by any means, electronic or mechanical, including photocopying and microfilm, without permission in writing from the SLSI

**Sri Lanka Standard**  
**METHODS OF TEST FOR WINDING WIRES PART 4: CHEMICAL PROPERTIES**  
*(Second Revision)*

## NATIONAL FOREWORD

This standard was approved by the Sectoral Committee on Electric Cables and Conductors and was authorized for adoption and publication as a Sri Lanka Standard by the Council of Sri Lanka Standards Institution on 2022-12-28.

This is the first revision of **SLS 1025 Part 4: 2009** and identical with **IEC 60851: Winding wires -Test methods, Part 4: 2016 Chemical Properties, Edition 3.0**, published by the International Electrotechnical Commission (IEC).

## TERMINOLOGY AND CONVENTIONS

The text of the International Standard has been accepted as suitable for publication, without deviation, as a Sri Lanka Standard. However, certain terminology and conventions are not identical with those used in Sri Lanka Standards, attention is therefore drawn to the following:

- a) Wherever the words “International Standard” appear referring to this standard they should be interpreted as “Sri Lanka Standard”.
- b) Wherever the page numbers are quoted they are the page numbers of IEC standard.
- c) The comma has been used as a decimal marker. In Sri Lanka Standards it is the current practice to use a full point on the base line as a decimal marker.

## CROSS REFERENCES

### International Standards

### Corresponding Sri Lanka Standards

IEC 60851 Winding wires – Test methods	SLS 1025 Methods of test for winding wires
Part 1: General	Part 1: General
Part 3: Mechanical properties	Part 3: Mechanical properties
Part 5: Electrical properties	Part 4: Electrical properties

No corresponding Sri Lanka Standard, for other International Standard listed under reference is not available





# INTERNATIONAL STANDARD

# NORME INTERNATIONALE

---

**Winding wires – Test methods –  
Part 4: Chemical properties**

**Fils de bobinage – Méthodes d’essai –  
Partie 4: Propriétés chimiques**





**THIS PUBLICATION IS COPYRIGHT PROTECTED**  
**Copyright © 2016 IEC, Geneva, Switzerland**

All rights reserved. Unless otherwise specified, no part of this publication may be reproduced or utilized in any form or by any means, electronic or mechanical, including photocopying and microfilm, without permission in writing from either IEC or IEC's member National Committee in the country of the requester. If you have any questions about IEC copyright or have an enquiry about obtaining additional rights to this publication, please contact the address below or your local IEC member National Committee for further information.

Droits de reproduction réservés. Sauf indication contraire, aucune partie de cette publication ne peut être reproduite ni utilisée sous quelque forme que ce soit et par aucun procédé, électronique ou mécanique, y compris la photocopie et les microfilms, sans l'accord écrit de l'IEC ou du Comité national de l'IEC du pays du demandeur. Si vous avez des questions sur le copyright de l'IEC ou si vous désirez obtenir des droits supplémentaires sur cette publication, utilisez les coordonnées ci-après ou contactez le Comité national de l'IEC de votre pays de résidence.

IEC Central Office  
3, rue de Varembe  
CH-1211 Geneva 20  
Switzerland

Tel.: +41 22 919 02 11  
Fax: +41 22 919 03 00  
[info@iec.ch](mailto:info@iec.ch)  
[www.iec.ch](http://www.iec.ch)

#### About the IEC

The International Electrotechnical Commission (IEC) is the leading global organization that prepares and publishes International Standards for all electrical, electronic and related technologies.

#### About IEC publications

The technical content of IEC publications is kept under constant review by the IEC. Please make sure that you have the latest edition, a corrigenda or an amendment might have been published.

#### IEC Catalogue - [webstore.iec.ch/catalogue](http://webstore.iec.ch/catalogue)

The stand-alone application for consulting the entire bibliographical information on IEC International Standards, Technical Specifications, Technical Reports and other documents. Available for PC, Mac OS, Android Tablets and iPad.

#### IEC publications search - [www.iec.ch/searchpub](http://www.iec.ch/searchpub)

The advanced search enables to find IEC publications by a variety of criteria (reference number, text, technical committee,...). It also gives information on projects, replaced and withdrawn publications.

#### IEC Just Published - [webstore.iec.ch/justpublished](http://webstore.iec.ch/justpublished)

Stay up to date on all new IEC publications. Just Published details all new publications released. Available online and also once a month by email.

#### Electropedia - [www.electropedia.org](http://www.electropedia.org)

The world's leading online dictionary of electronic and electrical terms containing 20 000 terms and definitions in English and French, with equivalent terms in 15 additional languages. Also known as the International Electrotechnical Vocabulary (IEV) online.

#### IEC Glossary - [std.iec.ch/glossary](http://std.iec.ch/glossary)

65 000 electrotechnical terminology entries in English and French extracted from the Terms and Definitions clause of IEC publications issued since 2002. Some entries have been collected from earlier publications of IEC TC 37, 77, 86 and CISPR.

#### IEC Customer Service Centre - [webstore.iec.ch/csc](http://webstore.iec.ch/csc)

If you wish to give us your feedback on this publication or need further assistance, please contact the Customer Service Centre: [csc@iec.ch](mailto:csc@iec.ch).

---

#### A propos de l'IEC

La Commission Electrotechnique Internationale (IEC) est la première organisation mondiale qui élabore et publie des Normes internationales pour tout ce qui a trait à l'électricité, à l'électronique et aux technologies apparentées.

#### A propos des publications IEC

Le contenu technique des publications IEC est constamment revu. Veuillez vous assurer que vous possédez l'édition la plus récente, un corrigendum ou amendement peut avoir été publié.

#### Catalogue IEC - [webstore.iec.ch/catalogue](http://webstore.iec.ch/catalogue)

Application autonome pour consulter tous les renseignements bibliographiques sur les Normes internationales, Spécifications techniques, Rapports techniques et autres documents de l'IEC. Disponible pour PC, Mac OS, tablettes Android et iPad.

#### Recherche de publications IEC - [www.iec.ch/searchpub](http://www.iec.ch/searchpub)

La recherche avancée permet de trouver des publications IEC en utilisant différents critères (numéro de référence, texte, comité d'études,...). Elle donne aussi des informations sur les projets et les publications remplacées ou retirées.

#### IEC Just Published - [webstore.iec.ch/justpublished](http://webstore.iec.ch/justpublished)

Restez informé sur les nouvelles publications IEC. Just Published détaille les nouvelles publications parues. Disponible en ligne et aussi une fois par mois par email.

#### Electropedia - [www.electropedia.org](http://www.electropedia.org)

Le premier dictionnaire en ligne de termes électroniques et électriques. Il contient 20 000 termes et définitions en anglais et en français, ainsi que les termes équivalents dans 15 langues additionnelles. Egalement appelé Vocabulaire Electrotechnique International (IEV) en ligne.

#### Glossaire IEC - [std.iec.ch/glossary](http://std.iec.ch/glossary)

65 000 entrées terminologiques électrotechniques, en anglais et en français, extraites des articles Termes et Définitions des publications IEC parues depuis 2002. Plus certaines entrées antérieures extraites des publications des CE 37, 77, 86 et CISPR de l'IEC.

#### Service Clients - [webstore.iec.ch/csc](http://webstore.iec.ch/csc)

Si vous désirez nous donner des commentaires sur cette publication ou si vous avez des questions contactez-nous: [csc@iec.ch](mailto:csc@iec.ch).





# INTERNATIONAL STANDARD

# NORME INTERNATIONALE

---

**Winding wires – Test methods –  
Part 4: Chemical properties**

**Fils de bobinage – Méthodes d’essai –  
Partie 4: Propriétés chimiques**

INTERNATIONAL  
ELECTROTECHNICAL  
COMMISSION

COMMISSION  
ELECTROTECHNIQUE  
INTERNATIONALE

---

ICS 29.060.10

ISBN 978-2-8322-3512-6

**Warning! Make sure that you obtained this publication from an authorized distributor.  
Attention! Veuillez vous assurer que vous avez obtenu cette publication via un distributeur agréé.**

## CONTENTS

FOREWORD.....	4
INTRODUCTION.....	6
1 Scope.....	7
2 Normative references.....	7
3 Test 12: Resistance to solvents .....	7
3.1 General.....	7
3.2 Equipment .....	8
3.3 Procedure .....	8
4 16: Resistance to refrigerants .....	9
4.1 General.....	9
4.2 Extraction .....	9
4.2.1 Principle .....	9
4.2.2 Equipment .....	9
4.2.3 Specimen.....	11
4.2.4 Procedure .....	11
4.2.5 Result.....	12
4.3 Breakdown voltage.....	12
4.3.1 Principle .....	12
4.3.2 Procedure .....	12
4.3.3 Result.....	13
5 Test 17: Solderability.....	13
5.1 General.....	13
5.2 Equipment .....	13
5.3 Procedure .....	14
6 Test 20: Resistance to hydrolysis and to transformer oil .....	14
6.1 General.....	14
6.2 Round wire .....	15
6.2.1 Equipment .....	15
6.2.2 Specimens.....	15
6.2.3 Procedure .....	15
6.3 Rectangular wire .....	16
6.3.1 Equipment .....	16
6.3.2 Specimens.....	16
6.3.3 Procedure .....	16
Annex A (informative) Alternative refrigerants to monochlorodifluoromethane.....	18
Bibliography .....	19
Figure 1 – Pencil and specimen for solvent test.....	8
Figure 2 – Refrigerant extractable test siphon cup .....	10
Figure 3 – Condenser coil .....	11
Figure 4 – Example of carrier for solderability test .....	14
Table 1 – Pencil hardness.....	9
Table 2 – Volume of components .....	16

Table A.1 – Alternative refrigerants to R 22 ..... 18

## INTERNATIONAL ELECTROTECHNICAL COMMISSION

---

**WINDING WIRES – TEST METHODS –****Part 4: Chemical properties****FOREWORD**

- 1) The International Electrotechnical Commission (IEC) is a worldwide organization for standardization comprising all national electrotechnical committees (IEC National Committees). The object of IEC is to promote international co-operation on all questions concerning standardization in the electrical and electronic fields. To this end and in addition to other activities, IEC publishes International Standards, Technical Specifications, Technical Reports, Publicly Available Specifications (PAS) and Guides (hereafter referred to as “IEC Publication(s)”). Their preparation is entrusted to technical committees; any IEC National Committee interested in the subject dealt with may participate in this preparatory work. International, governmental and non-governmental organizations liaising with the IEC also participate in this preparation. IEC collaborates closely with the International Organization for Standardization (ISO) in accordance with conditions determined by agreement between the two organizations.
- 2) The formal decisions or agreements of IEC on technical matters express, as nearly as possible, an international consensus of opinion on the relevant subjects since each technical committee has representation from all interested IEC National Committees.
- 3) IEC Publications have the form of recommendations for international use and are accepted by IEC National Committees in that sense. While all reasonable efforts are made to ensure that the technical content of IEC Publications is accurate, IEC cannot be held responsible for the way in which they are used or for any misinterpretation by any end user.
- 4) In order to promote international uniformity, IEC National Committees undertake to apply IEC Publications transparently to the maximum extent possible in their national and regional publications. Any divergence between any IEC Publication and the corresponding national or regional publication shall be clearly indicated in the latter.
- 5) IEC itself does not provide any attestation of conformity. Independent certification bodies provide conformity assessment services and, in some areas, access to IEC marks of conformity. IEC is not responsible for any services carried out by independent certification bodies.
- 6) All users should ensure that they have the latest edition of this publication.
- 7) No liability shall attach to IEC or its directors, employees, servants or agents including individual experts and members of its technical committees and IEC National Committees for any personal injury, property damage or other damage of any nature whatsoever, whether direct or indirect, or for costs (including legal fees) and expenses arising out of the publication, use of, or reliance upon, this IEC Publication or any other IEC Publications.
- 8) Attention is drawn to the Normative references cited in this publication. Use of the referenced publications is indispensable for the correct application of this publication.
- 9) Attention is drawn to the possibility that some of the elements of this IEC Publication may be the subject of patent rights. IEC shall not be held responsible for identifying any or all such patent rights.

International Standard IEC 60851-4 has been prepared by IEC technical committee 55: Winding wires.

This third edition cancels and replaces the second edition published in 1996, Amendment 1:1997 and Amendment 2:2005. This edition constitutes a technical revision.

This edition includes the following significant technical changes with respect to the previous edition:

- a) revision of Test 16: Resistance to refrigerants;
- b) revision of Test 17: Solderability;
- c) new Annex A for alternative refrigerants to monochlorodifluoromethane (R 22).

The text of this standard is based on the following documents:

FDIS	Report on voting
55/1578/FDIS	55/1580/RVD

Full information on the voting for the approval of this standard can be found in the report on voting indicated in the above table.

This publication has been drafted in accordance with the ISO/IEC Directives, Part 2.

A list of all the parts in the IEC 60851 series, published under the general title *Winding Wires – Test methods*, can be found on the IEC website.

The committee has decided that the contents of this publication will remain unchanged until the stability date indicated on the IEC website under "<http://webstore.iec.ch>" in the data related to the specific publication. At this date, the publication will be

- reconfirmed,
- withdrawn,
- replaced by a revised edition, or
- amended.

## INTRODUCTION

The IEC 60851 series is part of a group of International Standards which define insulated wires used for windings in electrical equipment:

- 1) IEC 60851 series, *Winding wires – Test methods*;
- 2) IEC 60317 series, *Specifications for particular types of winding wires*;
- 3) IEC 60264 series, *Packaging of winding wires*.

## WINDING WIRES – TEST METHODS –

### Part 4: Chemical properties

#### 1 Scope

This part of IEC 60851 specifies the following chemical properties tests:

- Test 12: Resistance to solvents;
- Test 16: Resistance to refrigerants;
- Test 17: Solderability;
- Test 20: Resistance to transformer oil.

For definitions, general notes on methods of test and the complete series of methods of test for winding wires see IEC 60851-1.

#### 2 Normative references

The following documents, in whole or in part, are normatively referenced in this document and are indispensable for its application. For dated references, only the edition cited applies. For undated references, the latest edition of the referenced document (including any amendments) applies.

IEC 60296, *Fluids for electrotechnical applications – Unused mineral insulating oils for transformers and switchgear*

IEC 60554-1:1977, *Specification for cellulosic papers for electrical purposes – Part 1: Definitions and general requirements*

IEC 60851-1, *Winding wires – Test methods – Part 1: General*

IEC 60851-3:2009, *Winding wires – Test methods – Part 3: Mechanical properties*

IEC 60851-5:2008, *Winding wires – Test methods – Part 5: Electrical properties*

ISO 9453, *Soft solder alloys – Chemical compositions and forms*

#### 3 Test 12: Resistance to solvents

##### 3.1 General

This test is applicable to enamelled round wire with a nominal conductor diameter over 0,250 mm and to enamelled rectangular wire.

The test is not suitable for round wires with a nominal conductor diameter up to and including 0,250 mm.

Resistance to solvents is expressed by the pencil hardness of the wire after solvent treatment.

### 3.2 Equipment

The following solvents shall be used:

- standard solvent as specified below, or
- solvent as agreed between purchaser and supplier.

The standard solvent shall be a mixture of:

- 60 % by volume white spirit with maximum aromatic content of 18 %;
- 30 % by volume xylene;
- 10 % by volume butanol.

The pencil to be used shall be a lead pencil of the hardness specified in the relevant standard. Before each test, the point of the pencil shall be sharpened with a smooth-cut file to form an angle of 60° symmetrical about the axis of the lead according to Figure 1.

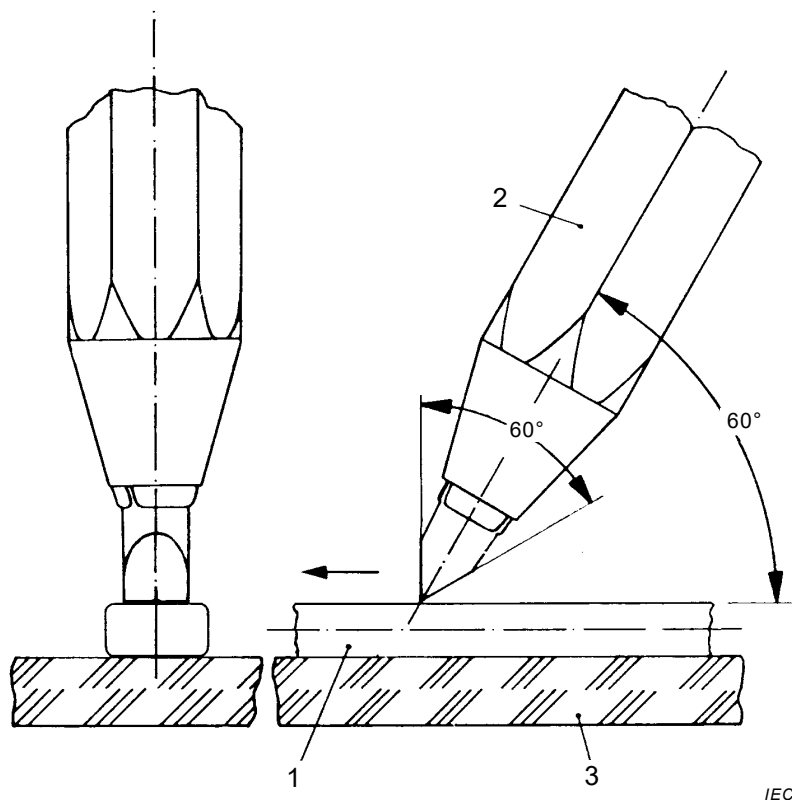

#### Key

- 1 Winding wire specimen
- 2 Pencil
- 3 Test surface

NOTE Angle tolerances  $\pm 5^\circ$ .

**Figure 1 – Pencil and specimen for solvent test**

### 3.3 Procedure

A straight piece of wire, approximately 150 mm in length, shall be preconditioned for  $(10 \pm 1)$  min at  $(130 \pm 3)^\circ\text{C}$  in an oven with forced air circulation. A substantial length of the wire shall then be immersed in standard solvent contained in a glass cylinder and shall be maintained therein at a temperature of  $(60 \pm 3)^\circ\text{C}$  for a period of  $(30 \pm 3)$  min. The wire shall



then be removed from the solvent. The hardness of the wire surface shall then be determined in the following manner within a period of 30 s after removal from the solvent.

The specimen to be tested shall be laid on a smooth hard surface according to Figure 1. In the case of rectangular wires, the test shall be carried out on the largest side of the wire. The pencil shall be placed on the surface of the wire at an angle of approximately  $(60 \pm 5)$  and the sharpened edge shall be pressed slowly along the surface of the wire with a force of approximately  $(5 \pm 0,5)$  N.

Three tests shall be made. It shall be reported if the coating is removed with exposure of the bare conductor.

NOTE 1 This method can also be used for testing resistance to other fluids, for example oil.

NOTE 2 Where it is desired to determine the hardness of the insulation, the hardness of the lead pencil which just fails to remove the coating from the surface of the conductor is considered to be the hardness of the wire surface, expressed by the pencil hardness. The pencil hardness series is as described in Table 1.

**Table 1 – Pencil hardness**

6B	5B	4B	3B	2B	B	HB	H	2H	3H	4H	5H	6H	7H	8H	9H
4	5	6	7	8	9	10	11	12	13	14	15	16	17	18	19

## 4 16: Resistance to refrigerants

### 4.1 General

This test is applicable to enamelled round wire.

Resistance to refrigerant is expressed by the quantity of matter extracted from the coating of the wire and by the breakdown voltage after exposure to a refrigerant.

NOTE 1 The data in this test method apply to monochlorodifluoromethane (refrigerant R 22). Other refrigerants that have been determined by investigation to be appropriate for this test are provided in Annex A. When these other refrigerants are used, it is important for safety reasons to observe the critical data for these refrigerants and to comply with the revised test conditions during operation of the pressure vessel.

NOTE 2 Refrigerants like monochlorodifluoromethane and rinsing fluids like trichlorotrifluoroethane (refrigerant R 113) are ozone depleting chemicals (ODC). Refrigerant and rinsing fluid are agreed upon between customer and supplier.

### 4.2 Extraction

#### 4.2.1 Principle

A siphon cup containing the wire sample is placed in the pressure vessel. The extractable matter is determined after exposure of the wire sample to the refrigerant under pressure and at elevated temperature.

#### 4.2.2 Equipment

The following equipment shall be used:

- siphon cup according to Figure 2, of 450 ml volume up to the siphoning level;
- pressure vessel of 2 000 ml volume with an internal diameter of approximately 100 mm and a pressure capacity of 200 bar (20 MPa), preferably of unwelded construction and provided with a controlled heating system;
- top closure of the vessel containing a condenser coil according to Figure 3;
- oven with forced air circulation.



**Key**

Height of cup:  $(82 \pm 5)$  mm

Diameter of cup:  $(84 \pm 5)$  mm

Diameter of tubing:  $(5 \pm 1)$  mm

**Figure 2 – Refrigerant extractable test siphon cup**



Figure 3 – Condenser coil

#### 4.2.3 Specimen

Eight wire samples each containing  $(0,6 \pm 0,1)$  g of insulation shall be wound into coils of 70 turns. The specimens shall be degreased and conditioned in an oven with forced air circulation at  $(150 \pm 3)$  °C for 15 min. After 30 min cooling, the eight specimens shall be weighed together to the nearest 0,000 1 g, resulting in the total initial mass  $M_1$ .

#### 4.2.4 Procedure

The eight specimens shall be placed in the siphon cup, which is suspended  $(25 \pm 5)$  mm below the condenser coil on the pressure vessel cover. The pressure vessel shall be assembled and charged with  $(700 \pm 25)$  g of distilled refrigerant free from lubricant. The condenser water supply and drain line shall be connected and the pressure vessel shall be heated by means of a controlled heating system with the temperature set to  $(75 \pm 5)$  °C or a lower temperature if required to comply with the conditions of the following paragraph relating to critical pressure. The water flowing through the condenser shall be adjusted to maintain a reflux rate of 20 to 25 discharges per hour from the siphon cup. The extraction period shall be 6 h.

The pressure in the vessel shall not exceed 75 % of the critical pressure of the refrigerant chosen. Therefore, prior to use, the over-pressure control valve shall be checked to ensure its proper functioning. The heating system should be automatically deactivated if the pressure exceeds 75 % of the critical pressure of the refrigerant chosen or if the water flow through the condenser coil is interrupted.

At the end of the extraction period the pressure vessel shall be cooled. The refrigerant shall be removed from the pressure vessel and recovered using suitable means such as a refrigerant compressor and recovery system. The pressure shall be released and the pressure vessel opened.

For the following operations, the rinsing fluid shall be distilled before use.

The specimens and siphon cup shall be rinsed with the agreed rinsing fluid, the rinse poured into the pressure vessel and the walls of the pressure vessel washed with two successive rinses each of 100 ml of rinsing fluid. The fluid shall then be evaporated to  $(5 \pm 1)$  mm from the bottom of the pressure vessel and recovered in a safe manner.

The liquid sample shall be transferred to a pre-dried tared aluminium weighing dish and the pressure vessel rinsed with 15 ml of rinsing fluid, which is transferred to the dish and then evaporated to dryness at  $(150 \pm 3)$  °C for (60 to 65) min. The weighing dish shall then be cooled to room temperature in a desiccator. The dish with the residue shall be weighed to the nearest 0,000 1 g and the original tared mass of the same dish subtracted. The difference is the total residue mass  $M_2$  of the matter extracted from the eight specimens.

The insulation on the coils shall be removed by suitable chemical means not affecting the conductor and the bare conductors shall be dried at  $(150 \pm 3)$  °C for  $(15 \pm 1)$  min and cooled to room temperature in a desiccator. They shall be weighed to the nearest 0,000 1 g and the mass of the eight conductors together is the total conductor mass  $M_3$ .

#### 4.2.5 Result

The extractable matter shall be determined according to the following equation :

$$\text{Extractable matter} = \frac{M_2}{M_1 - M_3} \times 100 \%$$

One test shall be made. The masses  $M_1$ ,  $M_2$ ,  $M_3$ , the refrigerant, rinsing fluid, temperature, pressure of the pressure vessel and the percentage extractable matter shall be reported.

### 4.3 Breakdown voltage

#### 4.3.1 Principle

A specimen prepared according to 4.4.1 of IEC 60851-5:2008 is placed in a pressure vessel according to 4.3.2. The breakdown voltage is determined after exposure of the specimen to the refrigerant under pressure and at elevated temperature.

#### 4.3.2 Procedure

The specimen shall be conditioned in the oven  $(150 \pm 3)$  °C for 4 h and then placed in the pressure vessel, which shall be assembled and charged with  $(1\,400 \pm 50)$  g of refrigerant. The pressure vessel shall be heated according to 4.2.4 but for a period of  $(72 \pm 1)$  h.

At the end of the exposure period, the pressure vessel shall be cooled and discharged as described under 4.2.4. When the pressure inside the tube is less than 2 bar (0,2 MPa) absolute, the pressure vessel shall be opened and the specimen, within a period of 25 s to 30 s, transferred to the oven at a temperature of  $(150 \pm 3)$  °C. The specimen shall remain in

the oven for  $(10 \pm 1)$  min. After the specimen is removed from the oven and allowed to cool to room temperature, the breakdown voltage shall be determined according to 4.4.1 of IEC 60851-5:2008.

#### 4.3.3 Result

Five specimens shall be tested. The five individual values shall be reported.

## 5 Test 17: Solderability

### 5.1 General

This test is applicable to enamelled round wire and bunched wire.

Solderability is expressed by the time of immersion of the specimen in a solder bath required to remove the coating and to coat the conductor with solder.

Safety warning: Chemical hazard – Lead has been recognized by regulatory agencies to be a hazardous substance. Primary routes of exposure are by inhalation and ingestion. The information contained in the Material safety data sheet (MSDS) for lead, tin, flux and alcohol must be adhered to while using, handling or disposing of these products. Adequate ventilation or forced exhausting of solder pot vapours and products of decomposition from various solderable insulations may be necessary to comply with environmental regulations.

**Safety warning:** Thermal hazard – Care shall be exercised in removing test specimens from the solder pot to avoid skin burns.

### 5.2 Equipment

The following equipment shall be used:

- temperature controlled solder bath of sufficient volume to maintain a constant solder temperature when immersing the specimen at any temperature specified in the relevant standard. Solder composition shall be of a mass ratio of 60 parts tin to 40 parts lead or a lead-free solder in accordance with ISO 9453 or as agreed upon between customer and supplier; any dross which forms shall be removed from the surface of the solder before each test; the temperature shall be controllable with  $\pm 5$  °C of the temperature specified in the relevant standard.

NOTE 1 Copper corrosion is greater when using lead free solder when compared to a tin/lead composition.

- any specimen holder that holds the wire under test free for at least 20 mm between the points of support when immersed into the solder (See Figure 4). The material used for the specimen holder shall be such that the solder does not undergo any contamination and the dimensions of the holder shall not lead to significant change of the bath temperature during immersion.

NOTE 2 Contamination of the solder due to oxidation or from copper can affect the results.

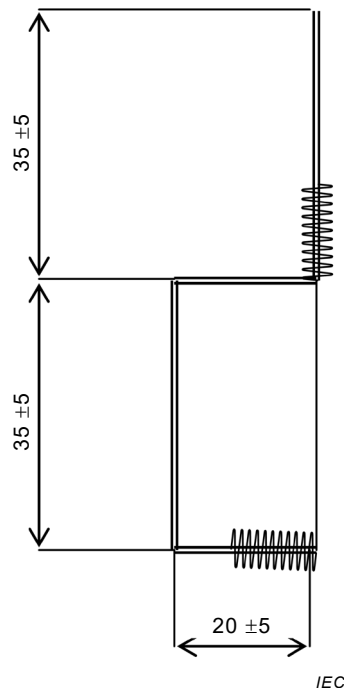
*Dimensions in millimetres***Figure 4 – Example of carrier for solderability test**

### 5.3 Procedure

The specimen shall be held vertically over the centre of the bath maintained at the temperature as specified in the relevant standard. The bottom end shall be lowered to  $(35 \pm 5)$  mm below the surface of the bath. The position at which the specimen is immersed shall be within 10 mm of the point where the temperature is measured. After immersion for the time specified in the relevant specification sheet, the specimen shall be moved sideways in the bath before it is withdrawn from the solder.

The surface of the tinned wire shall be examined with a magnification of 6 to 10 times. In the case of wire up to and including 0,100 mm nominal conductor diameter, the examination shall be restricted to the centre  $(25 \pm 2,5)$  mm free length section between the supports. In the case of wire over 0,100 mm nominal conductor diameter and bunched wires the examination shall be restricted to the lower 15 mm of the segment immersed in the pot.

Three specimens shall be tested. The condition of the surface of the wire shall be reported.

## 6 Test 20: Resistance to hydrolysis and to transformer oil

### 6.1 General

This test is applicable to enamelled wire.

Resistance to hydrolysis is expressed by appearance and adherence after exposure of the specimens to transformer oil in the presence of water under pressure and at elevated temperature.

Resistance to transformer oil is expressed by breakdown voltage and flexibility after exposure of the specimens to transformer oil under pressure and at elevated temperature.

NOTE The water can affect the coating by hydrolytic degradation and/or by absorption. If only absorption has occurred, drying the specimen at  $125\text{ °C} \pm 3\text{ °C}$  for 30 min prior to the breakdown voltage test will produce a recovery of the specimen. Wire with a nominal conductor diameter between 0,800 mm and 1,500 mm has been generally found convenient to handle and to test.

## 6.2 Round wire

### 6.2.1 Equipment

The following equipment shall be used:

- two glass tubes of 25 mm diameter and 300 mm length capable of being sealed;
- stainless steel pressure vessel of 400 ml to 500 ml volume with a pressure capacity of  $6 \times 10^6$  Pa, preferably of unwelded construction and provided with a controlled heating system;
- transformer oil according to IEC 60296;
- paper according to IEC 60554-1, type 1.

### 6.2.2 Specimens

The following specimens shall be prepared:

- 12 straight pieces of wire with a length of approximately two-thirds of the internal height of pressure vessel;
- 10 twisted pair specimens prepared in accordance with 4.4.1 of IEC 60851-5:2008 for nominal conductor diameter up to and including 2,500 mm or 10 straight specimens tested in accordance with 4.5.1 of IEC 60851-5:2008 for nominal conductor diameter over 2,500 mm;
- 3 mandrel-wound specimens prepared in accordance with 5.1.1 of IEC 60851-3:2009 for nominal conductor diameter up to and including 1,600 mm or 3 straight specimens tested in accordance with 5.2 of IEC 60851-3:2009 for a nominal conductor diameter over 1,600 mm.

### 6.2.3 Procedure

#### 6.2.3.1 Resistance to hydrolysis

Six straight pieces of wire prepared according to 6.2.2 are placed in the pressure vessel together with a quantity of de-aerated dry transformer oil sufficient to occupy  $(52,5 \pm 2,5)$  % of the volume of the pressure vessel. The pressure vessel shall be sealed and heated to  $(150 \pm 3)\text{ °C}$  for  $(24 \pm 1)$  h, after which it is allowed to cool to room temperature before opening. The specimens shall be examined with normal vision. The test shall be repeated with a quantity of water equal to  $(0,3 \pm 0,1)$  % of the volume of oil used being added to the pressure vessel.

One test shall be made. Any changes in appearance and adherence shall be reported.

#### 6.2.3.2 Resistance to transformer oil

Depending on the diameter and according to 6.2.2, the pressure vessel shall contain 10 twisted pair or straight specimens, three mandrel-wound or straight specimens and extra pieces of wire to arrive at the volume of coating specified in Table 2.

NOTE The total mass of wire in grams to provide the required volume of enamel can be calculated approximately by:

$$M = \frac{Y \times V}{600 \times \delta \times D}$$

where

$V$  is the volume of the pressure vessel in millilitres;

$Y$  is the mass of 1 m of wire in grams;

$\delta$  is the increase in diameter due to the coating in millimetres;

$D$  is the overall diameter of the wire in millimetres.

The pressure vessel shall be charged in accordance with the components and quantities specified in Table 2. Immediately prior to their addition, the oil and paper shall be dried and the oil de-aerated at a pressure of 2 kPa for  $(16 \pm 1)$  h at  $(90 \pm 3)$  °C or for  $(4 \pm 0,30)$  h at  $(105 \pm 3)$  °C.

**Table 2 – Volume of components**

Component	Container volume %
Transformer oil	$65 \pm 5$
Paper	$4 \pm 1$
Coating	$0,275 \pm 0,075$
Steel	<sup>a</sup>
<sup>a</sup> By agreement between purchaser and supplier.	

The sealed pressure vessel shall be heated to the class temperature of the wire  $\pm 3$  °C, or to  $(150 \pm 3)$  °C, if class temperature is higher than 150 °C, and maintained for  $(1\ 000 \pm 10)$  h. The pressure vessel shall then be allowed to cool to room temperature, discharged and opened. Five of the 10 specimens shall be tested at  $(105 \pm 3)$  °C for breakdown voltage with the specimens in air in accordance with either 4.4.2 or 4.5.2 of IEC 60851-5:2008, depending on the conductor diameter. The remaining five of the 10 specimens shall be dried at  $(125 \pm 3)$  °C for  $(30 \pm 5)$  min, allowed to cool to room temperature and then tested at  $(105 \pm 3)$  °C for breakdown voltage in air in accordance with either 4.4.2 or 4.5.2 of IEC 60851-5:2008, depending on the conductor diameter.

The three specimens shall be examined for cracks according to either 5.1.1.1 or 5.2 of IEC 60851-3:2009, depending on the conductor diameter.

One test shall be made. The individual values of breakdown voltage and any cracks shall be reported.

### 6.3 Rectangular wire

#### 6.3.1 Equipment

Equipment according to 6.2.1 shall be used.

#### 6.3.2 Specimens

The following specimens shall be prepared:

- 10 straight pieces of wire with a length of approximately two-thirds of the internal height of pressure vessel;
- four U-shaped specimens prepared in accordance with 4.7.1 of IEC 60851-5:2008;
- two mandrel bent specimens prepared in accordance with 5.1.2 of IEC 60851-3:2009.

#### 6.3.3 Procedure

##### 6.3.3.1 Resistance to hydrolysis

Each of the tubes shall be charged with five straight pieces of wire according to 6.3.2 and 80 ml de-aerated dry transformer oil. To one of the tubes,  $(0,24 \pm 0,01)$  ml of distilled water



shall be added. The two tubes shall be sealed and placed in an oven for 24 h at  $(150 \pm 3)$  °C. The tubes shall then be removed from the oven, and then allowed to cool down to room temperature and opened. The specimens shall be examined with normal vision.

One test shall be made. Any changes in appearance and adherence shall be reported.

### 6.3.3.2 Resistance to transformer oil

The pressure vessel shall contain four U-shaped specimens, two mandrel bent specimens and extra pieces of wire to arrive at the volume of coating specified in Table 2.

NOTE The total mass of wire in grams to provide the required volume of enamel can be calculated approximately by:

$$M = \frac{Y \times V}{385 \times \delta \times (W + T)}$$

where

$V$  is the volume of the pressure vessel in millilitres;

$Y$  is the mass of 1 m of wire in grams;

$\delta$  is the increase in thickness due to the coating in millimetres;

$W$  is the overall width of the wire in millimetres;

$T$  is the overall thickness of the wire in millimetres.

The pressure vessel shall then be charged, in accordance with the quantities specified in Table 2, with oil and paper which shall have been dried separately immediately prior to addition at a pressure of maximum 2 kPa for  $(16 \pm 1)$  h at  $(90 \pm 3)$  °C or for  $(4 \pm 0,1)$  h at  $(105 \pm 3)$  °C. The sealed pressure vessel shall be heated to the class temperature of the wire  $\pm 3$  °C, or to  $(150 \pm 3)$  °C if class temperature is higher than 150 °C, and maintained for  $(1\ 000 \pm 10)$  h. The pressure vessel shall then be allowed to cool to room temperature, discharged and opened. Two of the U-shaped specimens shall be tested at  $(105 \pm 3)$  °C for breakdown voltage in air in accordance with 4.7.2 of IEC 60851-5:2008. The remaining two of the U-shaped specimens shall be dried at  $(125 \pm 3)$  °C for  $(30 \pm 5)$  min, allowed to cool to room temperature and then tested at  $(105 \pm 3)$  °C for breakdown voltage in air according to 4.7.2 of IEC 60851-5:2008.

The mandrel-bent specimens shall be examined for cracks according to 5.1.2 of IEC 60851-3:2009.

One test shall be made. The individual values of breakdown voltage and any cracks shall be reported.

## Annex A (informative)

### Alternative refrigerants to monochlorodifluoromethane

Table A.1 provides a list of alternative refrigerants to monochlorodifluoromethane (R 22) that have been found through investigation to be suitable for use in Test 16.

For safety purposes and for their proper application during testing, observation of critical data in this table is recommended.

**Table A.1 – Alternative refrigerants to R 22**

Refrigerant	Composition (Weight percent)	Formula	Boiling Point	Critical Pressure	Critical Temperature
			°C	MPa	°C
R 22	Monochlorodifluoromethane	CHClF <sub>2</sub>	-41	5,0	96,2
R 134a	1,1,1,2 Tetrafluoroethane	CH <sub>2</sub> FCF <sub>3</sub>	-26	4,1	101,1
R 404a	Pentafluoroethane – 44 %	CF <sub>3</sub> -CHF <sub>2</sub>	-47	3,7	72,1
	1,1,1 Trifluoroethane – 52 %	CF <sub>3</sub> -CH <sub>3</sub>			
	1,1,1,2 Tetrafluoroethane – 4 %	CF <sub>3</sub> CH <sub>2</sub> F			
R 407c	R 32 – 23 %	CH <sub>2</sub> F <sub>2</sub>	-44	4,6	86,7
	R 125 – 25 %	C <sub>2</sub> HF <sub>5</sub>			
	R 134a – 52 %	CH <sub>2</sub> FCF <sub>3</sub>			
R 410a	R 32 – 50 %	CH <sub>2</sub> F <sub>2</sub>	-52	4,9	71,8
	R 125 – 50 %	C <sub>2</sub> HF <sub>5</sub>			
R 507	R 125 – 50 %	C <sub>2</sub> HF <sub>5</sub>	-47	3,8	70,9
	R 134a – 50 %	CH <sub>2</sub> FCF <sub>3</sub>			
Consultation with the refrigerant manufacturer is recommended for updated information.					

## Bibliography

IEC 60264 (all parts), *Packaging of winding wires*

IEC 60317 (all parts), *Specifications for particular types of winding wires*

IEC 60851 (all parts), *Winding wires – Test methods*

---

INTERNATIONAL  
ELECTROTECHNICAL  
COMMISSION

3, rue de Varembé  
PO Box 131  
CH-1211 Geneva 20  
Switzerland

Tel: + 41 22 919 02 11  
Fax: + 41 22 919 03 00  
[info@iec.ch](mailto:info@iec.ch)  
[www.iec.ch](http://www.iec.ch)

## **SLS CERTIFICATION MARK**

*The Sri Lanka Standards Institution is the owner of the registered certification mark shown below. Beneath the mark, the number of the Sri Lanka Standard relevant to the product is indicated. This mark may be used only by those who have obtained permits under the SLS certification marks scheme. The presence of this mark on or in relation to a product conveys the assurance that they have been produced to comply with the requirements of the relevant Sri Lanka Standard under a well designed system of quality control inspection and testing operated by the manufacturer and supervised by the SLSI which includes surveillance inspection of the factory, testing of both factory and market samples.*

*Further particulars of the terms and conditions of the permit may be obtained from the Sri Lanka Standards Institution, 17, Victoria Place, Elvitigala Mawatha, Colombo 08.*



## **SRI LANKA STANDARDS INSTITUTION**

The Sri Lanka Standards Institution (SLSI) is the National Standards Organization of Sri Lanka established under the Sri Lanka Standards Institution Act No. 6 of 1984 which repealed and replaced the Bureau of Ceylon Standards Act No. 38 of 1964. The Institution functions under the Ministry of Technology.

The principal objects of the Institution as set out in the Act are to prepare standards and promote their adoption, to provide facilities for examination and testing of products, to operate a Certification Marks Scheme, to certify the quality of products meant for local consumption or exports and to promote standardization and quality control by educational, consultancy and research activity.

The Institution is financed by Government grants, and by the income from the sale of its publications and other services offered for Industry and Business Sector. Financial and administrative control is vested in a Council appointed in accordance with the provisions of the Act.

The development and formulation of National Standards is carried out by Technical Experts and representatives of other interest groups, assisted by the permanent officers of the Institution. These Technical Committees are appointed under the purview of the Sectoral Committees which in turn are appointed by the Council. The Sectoral Committees give the final Technical approval for the Draft National Standards prior to the approval by the Council of the SLSI.

All members of the Technical and Sectoral Committees render their services in an honorary capacity. In this process the Institution endeavours to ensure adequate representation of all view points.

In the International field the Institution represents Sri Lanka in the International Organization for Standardization (ISO), and participates in such fields of standardization as are of special interest to Sri Lanka.