

SRI LANKA STANDARD 122 PART 1 : 2008
ISO 6507-1:2005

METALLIC MATERIALS – VICKERS
HARDNESS TEST
PART 1 : TEST METHOD

SRI LANKA STANDARDS INSTITUTION

**SRI LANKA STANDARD
METALLIC MATERIALS –VICKERS HARDNESS TEST
PART 1 : TEST METHOD**

**SLS 122 : PART 1 : 2008
ISO 6507-1 : 2005**

Gr. K

**SRI LANKA STANDARDS INSTITUTION
17, Victoria Place
Elvitigala Mawatha
Colombo - 08
SRI LANKA.**

Sri Lanka Standards are subject to periodical revision in order to accommodate the progress made by industry. Suggestions for improvement will be recorded and brought to the notice of the Committees to which the revisions are entrusted.

This standard does not purport to include all the necessary provisions of a contract.

© SLSI 2008

All rights reserved. Unless otherwise specified, no part of this publication may be reproduced or utilized in any form or by any means, electronic or mechanical, including photocopying and microfilm, without permission in writing from the SLSI.

SRI LANKA STANDARD
METALLIC MATERIALS –VICKERS HARDNESS TEST
PART 1 : TEST METHOD

NATIONAL FOREWORD

This standard was approved by the Sectoral Committee on Materials, Mechanical Systems and Manufacturing Engineering and was authorized for adoption and publication as a Sri Lanka Standard by the Council of the Sri Lanka Standards Institution on 2008-02-27.

This is the second revision of the SLS 122 and the revision is effected to fall in line with the International Standard.

SLS 122 : 2008 Metallic Materials – Vickers hardness test is published in four parts as follows:

- Part 1 : Test method
- Part 2 : Verification of testing machines
- Part 3 : Calibration of reference blocks
- Part 4 : Tables of hardness values

This Sri Lanka Standard is identical with ISO 6507 Metallic materials - Vickers hardness test – Part 1 : 2005 Test method, published by the International Organization for Standardization (ISO)

TERMINOLOGY AND CONVENTIONS

The text of the International Standard has been accepted as suitable for publication, without deviation as a Sri Lanka Standard. However certain terminology and conventions are not identical with those used in Sri Lanka Standards, attention is therefore drawn to the following :

- a) Wherever the words “International Standard” appear referring to this standard, they should be interpreted as “Sri Lanka Standard”.
- b) The comma has been used throughout as a decimal marker. In Sri Lanka Standards it is the current practice to use a full point on the baseline as the decimal marker.

Wherever page numbers are quoted, they are “ISO” page numbers.

CROSS REFERENCES

ISO 6507-2 : 2005 - SLS 122 : Part 2 : 2008
ISO 6507-4 : 2005 - SLS 122 : Part 4 : 2008

INTERNATIONAL
STANDARD

ISO
6507-1

Third edition
2005-12-15

**Metallic materials — Vickers hardness
test —**

**Part 1:
Test method**

Matériaux métalliques — Essai de dureté Vickers —

Partie 1: Méthode d'essai



Reference number
ISO 6507-1:2005(E)

PDF disclaimer

This PDF file may contain embedded typefaces. In accordance with Adobe's licensing policy, this file may be printed or viewed but shall not be edited unless the typefaces which are embedded are licensed to and installed on the computer performing the editing. In downloading this file, parties accept therein the responsibility of not infringing Adobe's licensing policy. The ISO Central Secretariat accepts no liability in this area.

Adobe is a trademark of Adobe Systems Incorporated.

Details of the software products used to create this PDF file can be found in the General Info relative to the file; the PDF-creation parameters were optimized for printing. Every care has been taken to ensure that the file is suitable for use by ISO member bodies. In the unlikely event that a problem relating to it is found, please inform the Central Secretariat at the address given below.

© ISO 2005

All rights reserved. Unless otherwise specified, no part of this publication may be reproduced or utilized in any form or by any means, electronic or mechanical, including photocopying and microfilm, without permission in writing from either ISO at the address below or ISO's member body in the country of the requester.

ISO copyright office
Case postale 56 • CH-1211 Geneva 20
Tel. + 41 22 749 01 11
Fax + 41 22 749 09 47
E-mail copyright@iso.org
Web www.iso.org

Published in Switzerland

Contents		Page
Foreword		iv
Introduction		v
1 Scope		1
2 Normative references		1
3 Principle		2
4 Symbols and abbreviated terms		2
5 Testing machine		3
6 Test piece		3
7 Procedure		3
8 Uncertainty of the results		5
9 Test report		5
Annex A (normative) Minimum thickness of the test piece in relation to the test force and to the hardness		6
Annex B (normative) Tables of correction factors for use in tests made on curved surfaces		8
Annex C (informative) Procedure for periodic checking of the testing machine by the user		12
Annex D (informative) Uncertainty of the measured hardness values		13
Bibliography		19

Foreword

ISO (the International Organization for Standardization) is a worldwide federation of national standards bodies (ISO member bodies). The work of preparing International Standards is normally carried out through ISO technical committees. Each member body interested in a subject for which a technical committee has been established has the right to be represented on that committee. International organizations, governmental and non-governmental, in liaison with ISO, also take part in the work. ISO collaborates closely with the International Electrotechnical Commission (IEC) on all matters of electrotechnical standardization.

International Standards are drafted in accordance with the rules given in the ISO/IEC Directives, Part 2.

The main task of technical committees is to prepare International Standards. Draft International Standards adopted by the technical committees are circulated to the member bodies for voting. Publication as an International Standard requires approval by at least 75 % of the member bodies casting a vote.

Attention is drawn to the possibility that some of the elements of this document may be the subject of patent rights. ISO shall not be held responsible for identifying any or all such patent rights.

ISO 6507-1 was prepared by Technical Committee ISO/TC 164, *Mechanical testing of metals*, Subcommittee SC 3, *Hardness testing*.

This third edition, together with ISO 6507-4, cancels and replaces the second edition (ISO 6507-1:1997) which has been technically revised.

ISO 6507 consists of the following parts, under the general title *Metallic materials — Vickers hardness test*:

- *Part 1: Test method*
- *Part 2: Verification and calibration of testing machines*
- *Part 3: Calibration of reference blocks*
- *Part 4: Tables of hardness values*

Introduction

The periodic checking of the testing machine described in informative Annex C is good metrological practice. It is intended to make the annex normative in the next revision of this part of ISO 6507 Standard.

For automated measuring systems this standard should be applied accordingly.

Metallic materials — Vickers hardness test —

Part 1: Test method

1 Scope

This part of ISO 6507 specifies the Vickers hardness test method, for the three different ranges of test force for metallic materials (see Table 1).

Table 1 — Ranges of test force

Ranges of test force, F N	Hardness symbol	Designation
$F \geq 49,03$	\geq HV 5	Vickers hardness test
$1,961 \leq F < 49,03$	HV 0,2 to < HV 5	Low-force Vickers hardness test
$0,098\ 07 \leq F < 1,961$	HV 0,01 to < HV 0,2	Vickers microhardness test

The Vickers hardness test is specified in this part of ISO 6507 for lengths of indentation diagonals between 0,020 mm and 1,400 mm.

NOTE 1 For indentation diagonals less than 0,020 mm, the increase of the uncertainty has to be considered.

NOTE 2 In general, decreasing the test force increases the scatter of results of the measurements. This is particularly true for low-force Vickers hardness tests and Vickers microhardness tests, where the principal limitation will arise in the measurement of the diagonals of the indentation. For Vickers microhardness, the accuracy of determination of the mean diagonal length is unlikely to be better than $\pm 0,001$ mm (see Bibliography [2]-[5]).

For specific materials and/or products, particular International Standards exist.

2 Normative references

The following referenced documents are indispensable for the application of this document. For dated references, only the edition cited applies. For undated references, the latest edition of the referenced document (including any amendments) applies.

ISO 6507-2:2005, *Metallic materials — Vickers hardness test — Part 2: Verification and calibration of testing machines*

ISO 6507-4, *Metallic materials — Vickers hardness test — Part 4: Tables of hardness values*

3 Principle

A diamond indenter, in the form of a right pyramid with a square base and with a specified angle between opposite faces at the vertex, is forced into the surface of a test piece followed by measurement of the diagonal length of the indentation left in the surface after removal of the test force, F (see Figure 1).

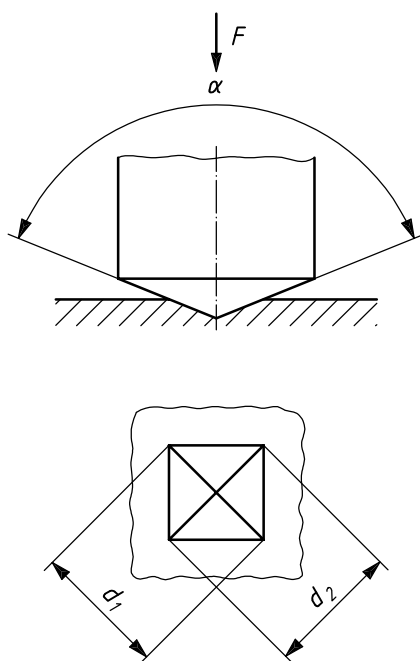

Figure 1 — Principle of the test

The Vickers hardness is proportional to the quotient obtained by dividing the test force by the sloping area of the indentation, which is assumed to be a right pyramid with a square base, and having at the vertex the same angle as the indenter.

4 Symbols and abbreviated terms

4.1 See Table 2 and Figure 1.

Table 2 — Symbols and abbreviated terms

Symbol/ Abbreviated term	Designation
α	Angle between the opposite faces at the vertex of the pyramidal indenter (136°)
F	Test force, in newtons (N)
d	Arithmetic mean, in millimetres, of the two diagonal lengths d_1 and d_2 (see Figure 1)
HV	Vickers hardness = Constant \times $\frac{\text{Test force}}{\text{Surface area of indentation}} = 0,102 \frac{2 F \sin \frac{136^\circ}{2}}{d^2} \approx 0,1891 \frac{F}{d^2}$
NOTE	Constant = 0,102 \approx 1/9,806 65, where 9,806 65 is the conversion factor from kgf to N.

4.2 The following is an example of the designation of Vickers hardness HV.

EXAMPLE

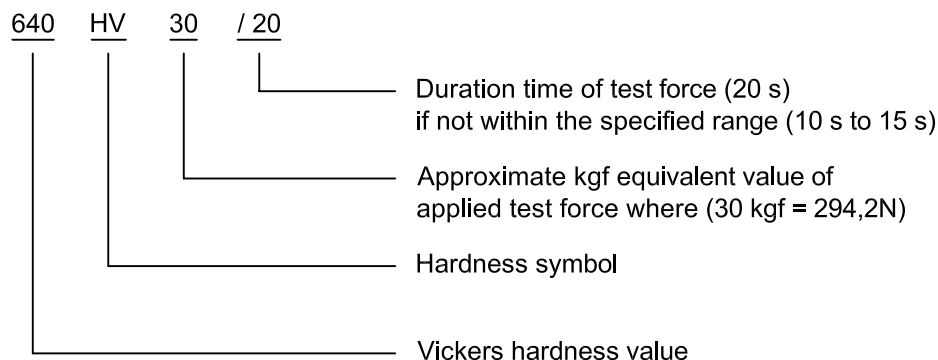

5 Testing machine

5.1 Testing machine, capable of applying a predetermined force or forces within the required range of test forces, in accordance with ISO 6507-2.

5.2 Indenter, a diamond in the shape of a right pyramid with a square base, as specified in ISO 6507-2.

5.3 Measuring system, as specified in ISO 6507-2.

NOTE A suggested procedure for periodic checks of the hardness testing machine by the users is given in Annex C.

6 Test piece

6.1 The test shall be carried out on a surface which is smooth and even, free from oxide scale, foreign matter and, in particular, completely free from lubricants, unless otherwise specified in product standards. The finish of the surface shall permit accurate determination of the diagonal length of the indentation.

6.2 Preparation shall be carried out in such a way that any alteration of the surface hardness, due to excessive heating or cold-working, for example, is minimized.

Due to the small depth of Vickers microhardness indentations, it is essential that special precautions are taken during preparation. It is recommended to use a polishing/electropolishing process which is suitable for the material parameters.

6.3 The thickness of the test piece, or of the layer under test, shall be at least 1,5 times the diagonal length of the indentation (see Annex A).

No deformation shall be visible at the back of the test piece after the test.

6.4 For tests on curved surfaces, the corrections given in Annex B, Tables B.1 to B.6 shall be applied.

6.5 For test pieces of small cross-section or of irregular shape, it may be necessary to provide some form of additional support.

7 Procedure

7.1 In general, the test is carried out at ambient temperature within the limits of 10 °C to 35 °C. Tests carried out under controlled conditions shall be made at a temperature of (23 ± 5) °C.

7.2 The test forces given in Table 3 are recommended.

NOTE Other values e.g. HV 2,5 (24,52 N) may be used.

Table 3 — Test forces

Hardness test ^a		Low-force hardness test		Microhardness test	
Hardness symbol	Nominal value of the test force F N	Hardness symbol	Nominal value of the test force F N	Hardness symbol	Nominal value of the test force F N
HV 5	49,03	HV 0,2	1,961	HV 0,01	0,098 07
HV 10	98,07	HV 0,3	2,942	HV 0,015	0,147
HV 20	196,1	HV 0,5	4,903	HV 0,02	0,196 1
HV 30	294,2	HV 1	9,807	HV 0,025	0,245 2
HV 50	490,3	HV 2	19,61	HV 0,05	0,490 3
HV 100	980,7	HV 3	29,42	HV 0,1	0,980 7

^a Nominal test forces greater than 980,7 N may be applied.

7.3 The test piece shall be placed on a rigid support. The support surfaces shall be clean and free from foreign matter (scale, oil, dirt, etc.). It is important that the test piece lies firmly on the support so that displacement cannot occur during the test.

7.4 Bring the indenter into contact with the test surface and apply the test force in a direction perpendicular to the surface, without shock or vibration, until the applied force attains the specified value. The time from the initial application of the force until the full test force is reached shall not be less than 2 s nor greater than 8 s. For low-force hardness and microhardness tests, the maximum time shall not exceed 10 s. For low-force hardness and microhardness tests, the approach speed of the indenter shall not exceed 0,2 mm/s.

For micro-hardness tests, the indenter should contact the test piece at a velocity between 15 µm/s and 70 µm/s.

The duration of the test force shall be 10 s to 15 s, except for tests on materials whose time-dependent properties would make this an unsuitable range. For these tests, a longer duration is permitted and this duration shall be specified as part of the hardness designation (see EXAMPLE in 4.2).

7.5 Throughout the test, the testing machine shall be protected from shock or vibration.

7.6 The distance between the centre of any indentation and the edge of the test piece shall be at least 2,5 times the mean diagonal length of the indentation in the case of steel, copper and copper alloys, and at least three times the mean diagonal length of the indentation in the case of light metals, lead and tin and their alloys.

The distance between the centres of two adjacent indentations shall be at least three times the mean diagonal length of the indentation in the case of steel, copper and copper alloys, and at least six times the mean diagonal length in the case of light metals, lead and tin and their alloys. If two adjacent indentations differ in size, the spacing shall be based on the mean diagonal length of the larger indentation.

7.7 Measure the lengths of the two diagonals. The arithmetical mean of the two readings shall be taken for the calculation of the Vickers hardness.

For flat surfaces, the difference between the lengths of two indentation diagonals should not be greater than 5 %. If the difference is greater, this shall be stated in the test report.

Magnifications should be provided so that the diagonal can be enlarged to greater than 25 %, but less than 75 % of the field of view.

7.8 ISO 6507-4 contains calculation tables which shall be used to determine the Vickers hardness for tests on flat surfaces.

8 Uncertainty of the results

A complete evaluation of the uncertainty should be done according to the ISO *Guide to the expression of uncertainty in measurement* (GUM) [6].

Independent of the type of sources, for hardness there are two possibilities for the determination of the uncertainty.

- One possibility is based on the evaluation of all relevant sources appearing during a direct calibration. As a reference, an EA guideline [7] is available.
- The other possibility is based on indirect calibration using a hardness reference block [below abbreviated as CRM (certified reference material)] (see [7-10] in the Bibliography). A guideline for the determination is given in Annex D.

It may not always be possible to quantify all the identified contributions to the uncertainty. In this case, an estimate of type A standard uncertainty may be obtained from the statistical analysis of repeated indentations into the test piece. Care should be taken, if standard uncertainties of type A and B are summarised, that the contributions are not counted twice (see Clause 4 of GUM:1993).

9 Test report

The test report shall include the following information:

- a) a reference to this part of ISO 6507;
- b) all details necessary for identification of the test piece;
- c) the result obtained;
- d) all operations not specified in this part of ISO 6507, or regarded as optional;
- e) details of any occurrence which may have affected the results;
- f) the temperature of the test, if it is outside the range specified in 7.1.

NOTE 1 A strict comparison of hardness values is only possible at identical test forces.

There is no general process of accurately converting Vickers hardness into other scales of hardness or into tensile strength. Such conversions, therefore, should be avoided, unless a reliable basis for conversion can be obtained by comparison tests.

It should be noted that for anisotropic materials, for example those which have been heavily cold-worked, there will be a difference between the lengths of the two diagonals of the indentation. Where possible, the indentation should be made so that the diagonals are inclined at approximately 45° to the direction of cold-working. The specification for the product may indicate limits for the differences between the lengths of the two diagonals.

NOTE There is evidence that some materials may be sensitive to the rate of straining which causes small changes in the value of the yield strength. The corresponding effect on the termination of the formation of an indentation can make alterations in the hardness value.

Annex A (normative)

Minimum thickness of the test piece in relation to the test force and to the hardness

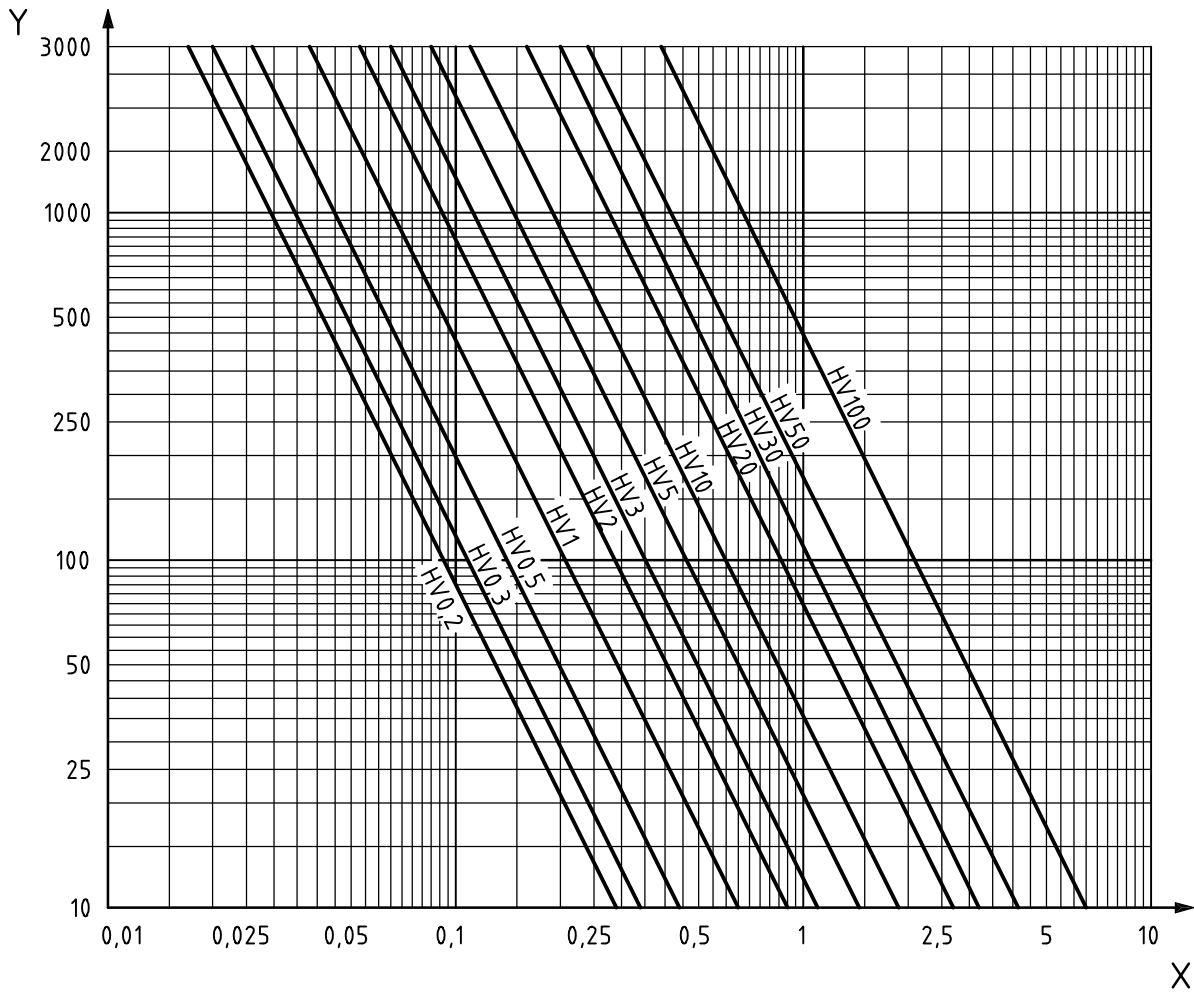

Key

- X Thickness of the test piece, mm
- Y Hardness, HV

Figure A.1 — Minimum thickness of the test piece in relation to the test force and to the hardness (HV 0,2 to HV 100)

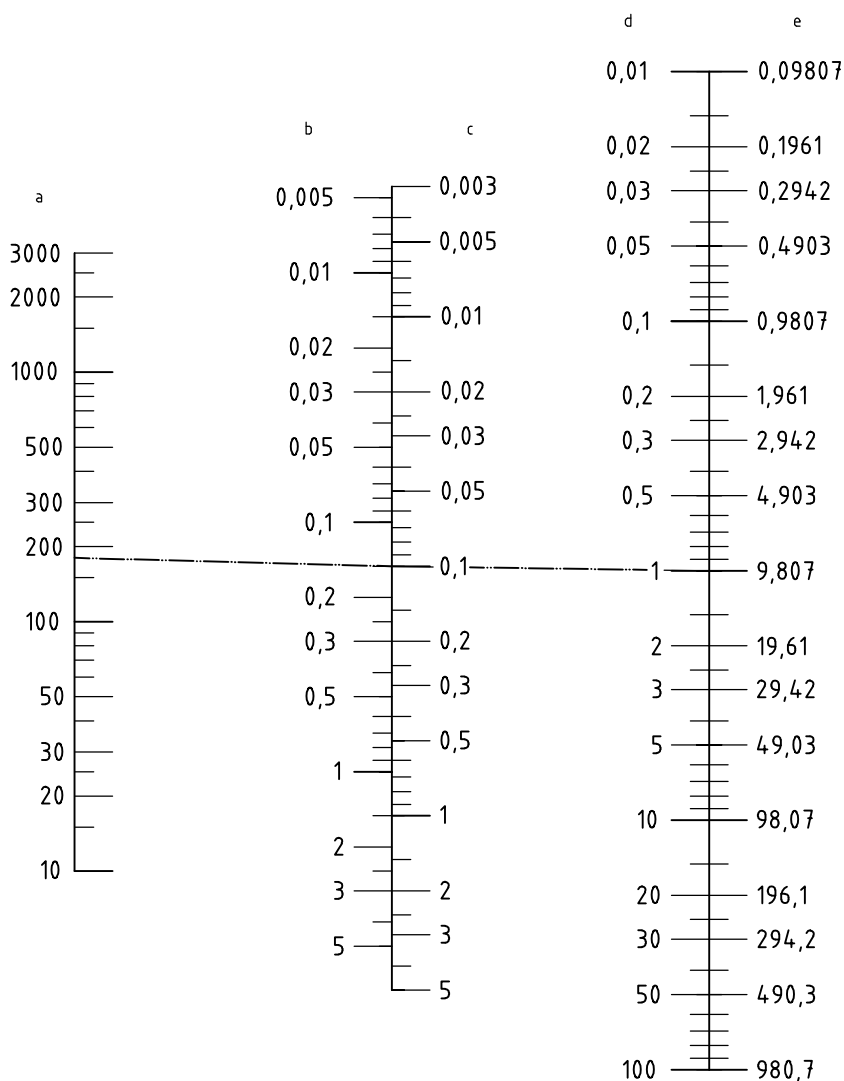

Key

- a Hardness value, HV
- b Minimum thickness, t , mm
- c Diagonal length, d , mm
- d Hardness symbol, HV
- e Test force F , N

Figure A.2 — Nomogram designed for the minimum thickness of the test piece (HV 0,01 to HV 100)

The nomogram shown in Figure A.2 has been designed for the minimum thickness of a test piece, assuming that the minimum thickness has to be 1,5 times the diagonal length of the indentation. The required thickness is given by the point of intersection of the minimum thickness scale and a line (shown dotted in the example in Figure A.2) joining the test force (right-hand scale) with the hardness (left-hand scale).

Annex B (normative)

Tables of correction factors for use in tests made on curved surfaces

B.1 Spherical surfaces

Tables B.1 and B.2 give the correction factors when tests are made on spherical surfaces.

The correction factors are tabulated in terms of the ratio of the mean diagonal d of the indentation to the diameter D of the sphere.

EXAMPLE Convex sphere, $D = 10$ mm

Test force, $F = 98,07$ N

Mean diagonal of indentation, $d = 0,150$ mm

$$\frac{d}{D} = \frac{0,150}{10} = 0,015$$

$$\text{Vickers hardness } 0,1891 \times \frac{98,07}{(0,15)^2} = 824 \text{ HV } 10$$

Correction factor from Table B.1, by interpolation = 0,983

Hardness of sphere = $824 \times 0,983 = 810$ HV 10

Table B.1 — Convex spherical surfaces

d/D	Correction factor	d/D	Correction factor
0,004	0,995	0,086	0,920
0,009	0,990	0,093	0,915
0,013	0,985	0,100	0,910
0,018	0,980	0,107	0,905
0,023	0,975	0,114	0,900
0,028	0,970	0,122	0,895
0,033	0,965	0,130	0,890
0,038	0,960	0,139	0,885
0,043	0,955	0,147	0,880
0,049	0,950	0,156	0,875
0,055	0,945	0,165	0,870
0,061	0,940	0,175	0,865
0,067	0,935	0,185	0,860
0,073	0,930	0,195	0,855
0,079	0,925	0,206	0,850

Table B.2 — Concave spherical surfaces

<i>d/D</i>	Correction factor	<i>d/D</i>	Correction factor
0,004	1,005	0,057	1,080
0,008	1,010	0,060	1,085
0,012	1,015	0,063	1,090
0,016	1,020	0,066	1,095
0,020	1,025	0,069	1,100
0,024	1,030	0,071	1,105
0,028	1,035	0,074	1,110
0,031	1,040	0,077	1,115
0,035	1,045	0,079	1,120
0,038	1,050	0,082	1,125
0,041	1,055	0,084	1,130
0,045	1,060	0,087	1,135
0,048	1,065	0,089	1,140
0,051	1,070	0,091	1,145
0,054	1,075	0,094	1,150

B.2 Cylindrical surfaces

Tables B.3 to B.6 give the correction factors when tests are made on cylindrical surfaces.

The correction factors are tabulated in terms of the ratio of the mean diagonal *d* of the indentation to the diameter *D* of the cylinder.

EXAMPLE Concave cylinder, one diagonal of the indentation parallel to axis, *D* = 5 mm

Test force, *F* = 294,2 N

Mean diagonal of indentation, *d* = 0,415 mm

$$\frac{d}{D} = \frac{0,415}{5} = 0,083$$

$$\text{Vickers hardness} = 0,189 1 \times \frac{294,2}{(0,415)^2} = 323 \text{ HV } 30$$

Correction factor from Table B.6 = 1,075

Hardness of cylinder = 323 × 1,075 = 347 HV 30

Table B.3 — Convex cylindrical surfaces — Diagonals at 45° to the axis

<i>d/D</i>	Correction factor	<i>d/D</i>	Correction factor
0,009	0,995	0,119	0,935
0,017	0,990	0,129	0,930
0,026	0,985	0,139	0,925
0,035	0,980	0,149	0,920
0,044	0,975	0,159	0,915
0,053	0,970	0,169	0,910
0,062	0,965	0,179	0,905
0,071	0,960	0,189	0,900
0,081	0,955	0,200	0,895
0,090	0,950		
0,100	0,945		
0,109	0,940		

Table B.4 — Concave cylindrical surfaces — Diagonals at 45° to the axis

<i>d/D</i>	Correction factor	<i>d/D</i>	Correction factor
0,009	1,005	0,127	1,080
0,017	1,010	0,134	1,085
0,025	1,015	0,141	1,090
0,034	1,020	0,148	1,095
0,042	1,025	0,155	1,100
0,050	1,030	0,162	1,105
0,058	1,035	0,169	1,110
0,066	1,040	0,176	1,115
0,074	1,045	0,183	1,120
0,082	1,050	0,189	1,125
0,089	1,055	0,196	1,130
0,097	1,060	0,203	1,135
0,104	1,065	0,209	1,140
0,112	1,070	0,216	1,145
0,119	1,075	0,222	1,150

Table B.5 — Convex cylindrical surfaces — One diagonal parallel to the axis

<i>d/D</i>	Correction factor	<i>d/D</i>	Correction factor
0,009	0,995	0,085	0,965
0,019	0,990	0,104	0,960
0,029	0,985	0,126	0,955
0,041	0,980	0,153	0,950
0,054	0,975	0,189	0,945
0,068	0,970	0,243	0,940

Table B.6 — Concave cylindrical surfaces — One diagonal parallel to the axis

<i>d/D</i>	Correction factor	<i>d/D</i>	Correction factor
0,008	1,005	0,087	1,080
0,016	1,010	0,090	1,085
0,023	1,015	0,093	1,090
0,030	1,020	0,097	1,095
0,036	1,025	1,100	1,100
0,042	1,030	0,103	1,105
0,048	1,035	0,105	1,110
0,053	1,040	0,108	1,115
0,058	1,045	0,111	1,120
0,063	1,050	0,113	1,125
0,067	1,055	0,116	1,130
0,071	1,060	0,118	1,135
0,076	1,065	0,120	1,140
0,079	1,070	0,123	1,145
0,083	1,075	0,125	1,150

Annex C (informative)

Procedure for periodic checking of the testing machine by the user

A check of the machine should be carried out on each day that the machine is used, at approximately each hardness level and for each range or scale that is to be used.

Prior to making the check, the measuring system should be indirectly verified (for each range/scale and hardness level) using a reference indentation on a hardness reference block, calibrated in accordance with ISO 6507-3. The measured dimension should agree with the certified value to within the maximum permissible error given in Table 5 of ISO 6507-2:2005. If the measuring system fails this test, appropriate action should be taken.

The check involves at least one indentation being made on a hardness reference block, calibrated in accordance with ISO 6507-3. If the difference between the mean measured hardness and the block's certified value is within the permissible error limits given in Table 5 of ISO 6507-2:2005, the machine may be regarded as satisfactory. If not, an indirect verification should be performed.

A record of these results should be maintained over a period of time, and used to measure reproducibility and monitor drift of the machine.

Annex D (informative)

Uncertainty of the measured hardness values

D.1 General requirements

The approach for determining uncertainty presented in this annex considers only those uncertainties associated with the overall measurement performance of the hardness testing machine with respect to the hardness reference blocks (abbreviated as CRM below). These performance uncertainties reflect the combined effect to all the separate uncertainties (indirect verification). Because of this approach, it is important that the individual machine components are operating within the tolerances. It is strongly recommended that this procedure be applied for a maximum of one year after the successful passing of a direct verification.

Figure D.1 shows the four-level structure of the metrological chain necessary to define and disseminate hardness scales. The chain starts at the **international level** using international definitions of the various hardness scales to carry out international intercomparisons. A number of *primary hardness standard machines* at the **national level** “produce” *primary hardness reference blocks* for the calibration laboratory level. Naturally, direct calibration and the verification of these machines should be at the highest possible accuracy.

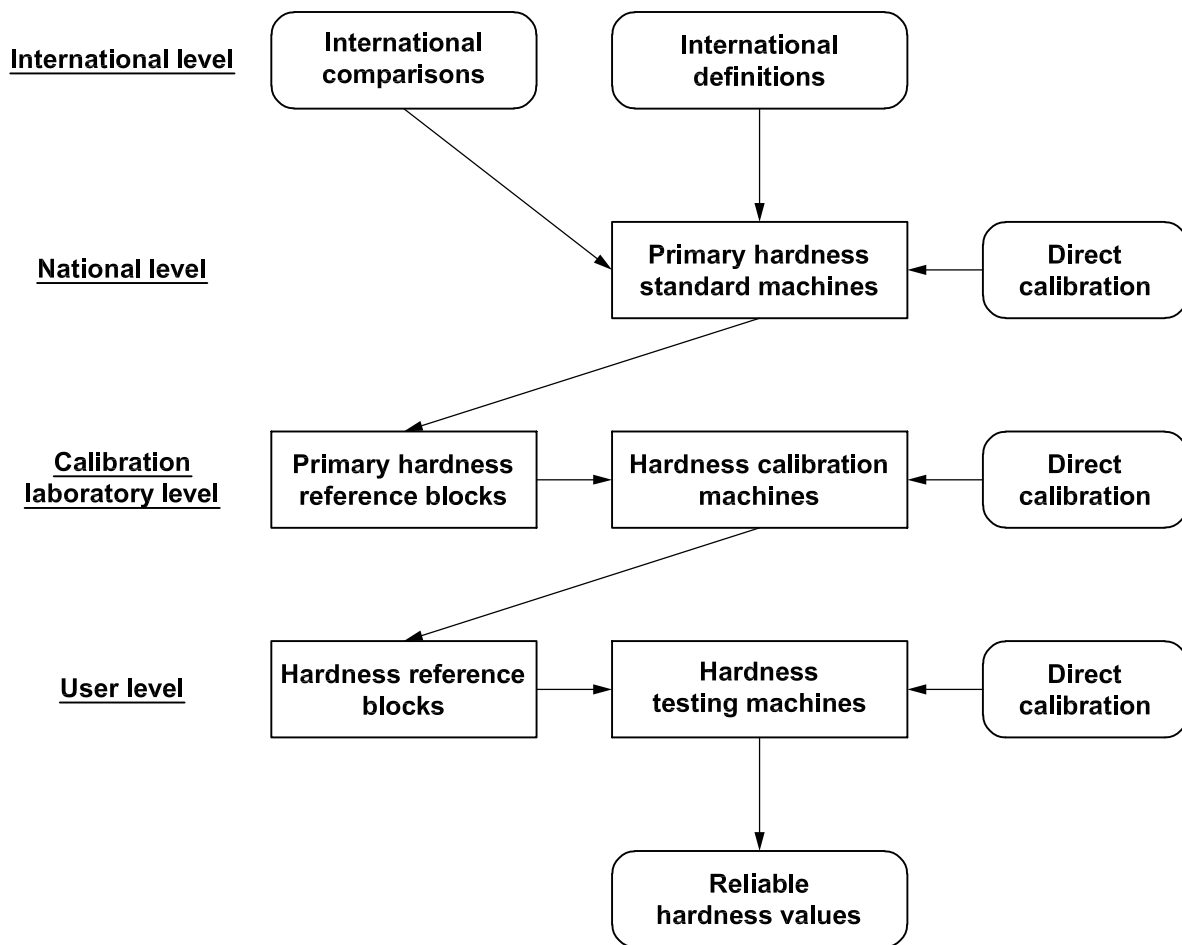

Figure D.1 — Structure of the metrological chain for the definition and dissemination of hardness scales

D.2 General procedure

The procedure calculates a combined uncertainty u_1 by the Root-Squared-Sum-Method (RSS) out of the different sources given in Table D.1. The expanded uncertainty, U , is derived from u_1 by multiplying with the coverage factor $k = 2$. Table D.1 contains all symbols and their designation.

D.3 Bias of the machine

The bias b of a hardness testing machine (also named error) which is derived from the difference between

- the mean value of the five indentations during calibration of the hardness testing machine, and
- the calibration value of the hardness reference block,

can be implemented in different ways into the determination of uncertainty.

D.4 Procedures for calculating uncertainty: Hardness measurement values

NOTE In this Annex, the index “CRM (Certified Reference Material)” means, according to the definitions of the hardness testing standards, “Hardness Reference Block”.

D.4.1 Procedure without bias (method 1)

Method 1 (abbreviated as M1) is a simplified method, which can be used without considering the systematic error of the hardness testing machine.

In M1, the error limit, that means the range in which the machine is allowed to differ from the reference standard is used to define the source u_E of the uncertainty. There is no correction of the hardness values with respect to the error.

The procedure for the determination of U is explained in Table D.1 (see [6, 7] in the Bibliography).

$$U_{\text{corr}} = k \cdot \sqrt{u_E^2 + u_{\text{CRM}}^2 + u_H^2 + u_{\bar{x}}^2 + u_{\text{ms}}^2} \quad (\text{D.1})$$

Where the result of the measurement is given by

$$\bar{X} = \bar{x} \pm U \quad (\text{D.2})$$

D.4.2 Procedure with bias (method 2)

As an alternative to (M1), method 2 may be used, which is correlated with the conduct of a control chart. M2 may lead to smaller values of uncertainty.

The error b (step 10) can be expected to be a systematic effect. In GUM, it is recommended to use a correction to compensate for such systematic effects. This is the base of M2. The error is no longer in the calculation of the uncertainty but all determined hardness values have to be corrected by b or U_{corr} has to be increased by b . The procedure for the determination of U_{corr} is explained in Table D.1, (see [9, 10] in the Bibliography).

$$U_{\text{corr}} = k \cdot \sqrt{u_{\text{CRM}}^2 + u_H^2 + u_{\bar{x}}^2 + u_{\text{ms}}^2 + u_b^2} \quad (\text{D.3})$$

Where the result of the measurement is given by

$$\bar{X}_{\text{corr}} = (\bar{x} + \bar{b}) \pm U_{\text{corr}} \quad (\text{D.4})$$

or by

$$\bar{X}_{u_{\text{corr}}} = \bar{x} \pm (U_{\text{corr}} + |\bar{b}|) \quad (\text{D.5})$$

depending on whether the bias (error) \bar{b} is thought to be part of the mean value or of the uncertainty.

D.5 Expression of the result of measurement

For the expression of the result of measurement, the method used should be indicated. In general, as a result of the measurement, method 1 [Equation (D.2)] should be used (see also Table D.1, step 12).

Table D.1 — Determination of the expanded uncertainty according to methods M1 and M2

Step Method	Sources of uncertainty	Symbols	Formula	Literature/Certificate	Example [.] = HV1
1 M1	Standard uncertainty according to the maximum permissible error	u_E	$u_E = \frac{u_{E,2r} \cdot \bar{X}_{CRM}}{2,8}$	Permissible error $u_{E,2r}$ according to ISO 6507-2:2005, Table 5. \bar{X}_{CRM} from calibration certificate. See Note 1.	$u_E = \frac{0,04 \times 376}{2,8} = 5,37$
2 M1 M2	Standard uncertainty and mean value of hardness of CRM (for detailed calculation see ISO 6507-3:2005, Table A.4)	u_{CRM} , \bar{X}_{CRM}	$u_{CRM} = \frac{U_{CRM}}{2}$	U_{CRM} , \bar{X}_{CRM} according to calibration certificate of CRM. See Note 2.	$u_{CRM} = \frac{6,00}{2} = 3,00$ $\bar{X}_{CRM} = 376,0$
3 M1 M2	Mean value and standard deviation of the measurement on CRM	\bar{H} , s_H	$\bar{H} = \frac{\sum_{i=1}^n H_i}{n}$ $s_H = \sqrt{\frac{1}{n-1} \sum_{i=1}^n (H_i - \bar{H})^2}$	H_i according to ISO 6507-2:2005, 5.9. For the calculation of s_H , the larger value of s_{H1} and s_{H2} will be taken.	Single measurements: (1) 377 – 376 – 377 – 377 – 377 $\bar{H}_1 = 376,8$; $s_{H1} = 0,45$ (2) 376 – 377 – 376 – 378 – 376 $\bar{H}_2 = 376,6$; $s_{H2} = 0,89$
4 M1 M2	Standard uncertainty of hardness testing machine when measuring CRM	u_H	$u_H = \frac{t \cdot s_H}{\sqrt{n}}$	$t = 1,4$ for $n = 5$	$u_H = \frac{1,14 \times 0,89}{\sqrt{5}} = 0,45$
5 M1 M2	Mean value and standard deviation of the testing of a test piece	\bar{x} , s_x	$\bar{x} = \frac{\sum_{i=1}^n x_i}{n}$ $s_x = \sqrt{\frac{1}{n-1} \sum_{i=1}^n (x_i - \bar{x})^2}$	$n = 5$ measurements on the test piece. See Note 3. If $n = 1$, $s_x = 0$. The certificate should state that the uncertainty applies only to the specific reading, not to the test piece as a whole.	Single values 419 – 439 – 449 – 442 – 444 $\bar{x} = 438,6$ $s_x = 1,155$

Table D.1 (continued)

Step Method	Sources of uncertainty	Symbols	Formula	Literature/Certificate	Example [.] = HV1
6 M1 M2	Standard uncertainty when measuring a test piece	$u_{\bar{x}}$	$u_{\bar{x}} = \frac{t \cdot s_x}{\sqrt{n}}$	$t = 1,14$ for $n = 5$	$u_{\bar{x}} = \frac{1,14 \times 11,55}{\sqrt{5}} = 5,89$
7 M2	Standard uncertainty according to the resolution of the length measuring system	u_{ms}	$u_{ms} = \frac{2H}{d} \cdot \frac{\delta_{ms}}{2\sqrt{3}}$	$\delta_{ms} = 0,0001$ mm $H = 438,6$ HV $d = 0,065$ mm	$u_{ms} = \frac{438,6}{0,065} \times \frac{0,0001}{\sqrt{3}} = 0,39$
8 M2	Deviation of hardness testing machine from calibration value	\bar{b}	$\bar{b} = \bar{H} - \bar{X}_{CRM}$	Steps 2 and 3. See Note 4.	$b_1 = 376,8 - 376 = 0,8$ $b_2 = 376,6 - 376 = 0,6$
9 M2	Standard deviation of the deviation b	s_b	$\bar{b} = \frac{1}{n_m} \sum_{i=1}^{n_m} b_i$ $s_b = \sqrt{\frac{1}{n_m - 1} \sum_{i=1}^{n_m} (b_i - \bar{b})^2}$	Step 8 $n_m = 2$ number of measurement series	$\bar{b} = 0,7$ $s_b = 0,14$
10 M2	Standard uncertainty of the determination of b . Can be determined only after the second series of measurements	u_b	$u_b = \frac{t \cdot s_b}{\sqrt{n_m}}$	Step 9 $t = 1,84$ for $n_m = 2$ See Note 5.	$u_b = \frac{1,84 \times 0,14}{\sqrt{2}} = 0,18$
11 M1	Determination of the expanded uncertainty	U	$U = k \cdot \sqrt{u_E^2 + u_{CRM}^2 + u_{\bar{H}}^2 + u_{\bar{x}}^2 + u_{ms}^2}$	Steps 1 to 7 $k = 2$	$U = 2 \times \sqrt{5,37^2 + 3,00^2 + 0,46^2 + 5,94^2 + 0,39^2}$ $U = 17,14$ HV
12 M1	Result of the measurement	\bar{X}	$\bar{X} = \bar{x} \pm U$	Steps 5 and 11	$\bar{X} = 438,6 \pm 17,1$ HV (M1)
13 M2	Determination of the corrected expanded uncertainty	U_{corr}	$U_{corr} = k \cdot \sqrt{u_{CRM}^2 + u_{\bar{H}}^2 + u_{\bar{x}}^2 + u_{ms}^2 + u_b^2}$	Steps 2 to 7 and 10 $k = 2$	$U_{corr} = 2 \times \sqrt{3,00^2 + 0,46^2 + 5,94^2 + 0,39^2 + 0,18^2}$ $U_{corr} = 13,36$ HV

Table D.1 (continued)

Step Method	Sources of uncertainty	Symbols	Formula	Literature/Certificate	Example [.] = HV1
14 M2	Result of the measurement with corrected mean value	\bar{X}_{corr}	$\bar{X}_{\text{corr}} = (\bar{x} + \bar{b}) \pm U_{\text{corr}}$	Steps 5, 8 and 13	$\bar{X}_{\text{corr}} = (439,8 \pm 13,4)$ HV (M2)
15 M2	Result of the measurement with corrected uncertainty	$\bar{X}_{u_{\text{corr}}}$	$\bar{X}_{u_{\text{corr}}} = \bar{x} \pm (U_{\text{corr}} + \bar{b})$	Steps 5, 8 and 13	$\bar{X}_{u_{\text{corr}}} = (438,6 \pm 14,1)$ HV (M2)
NOTE 1	The factor 2,8 is derived from the determination of the standard uncertainty for a rectangular distribution.				
NOTE 2	If necessary, the hardness change of the CRM has to be considered.				
NOTE 3	If between the measurement of CRM and test piece the optics of the device are changed, the corresponding influence should be considered.				
NOTE 4	If $0,8 u_{E,2r} < b < 1,0 u_{E,2r}$, the relationship of hardness values between CRM and sample should be considered.				
NOTE 5	Because, for $n_m = 2$, in the uncertainty u_b the influence of the long-term change of b is not contained, for critical applications it may be necessary to raise the number of measurements n_m .				

Bibliography

- [1] ISO 6507-3, *Metallic materials — Vickers hardness test — Part 3: Calibration of reference blocks*
- [2] BÜCKLE, H. *Mikrohärteprüfung und ihre Anwendung*. Verlag Berliner Union Stuttgart, 1965, pp 296. (Note: very extensive.)
- [3] BÜCKLE, H. *Echte und scheinbare Fehlerquellen bei der Mikrohärteprüfung: Ihre Klassifizierung und Auswirkung auf die Messwerte*. *VDI-Berichte* **11** (1957), pp. 29-43. (Note: extensive.)
- [4] DENGEL, D. *Wichtige Gesichtspunkte für die Härtemessung nach Vickers und nach Knoop im Bereich der Kleinlast- und Mikrohärte*, *Z. f. Werkstofftechnik* **4** (1973), pp. 292-298. (Note: short extract.)
- [5] MATTHAEI, E. *Härteprüfung mit kleinen Prüfkraften und ihre Anwendung bei Randschichten (kritische Literaturbewertung)*, pp. 47, 192 Schrifttumshinweise. Verlag DGM-Informationsgesellschaft Oberursel, 1987. (Note: overall view of sources.)
- [6] BIPM, IEC, IFCC, ISO, IUPAC, IUPAP, OIML. *Guide to the Expression of Uncertainty in Measurement*, 1993 ¹⁾
- [7] EA 10-16, *Guidelines on the Estimation of Uncertainty in Hardness Measurements*, 2001
- [8] GABAUER, W. *Manual of Codes of Practice for the Determination of Uncertainties in Mechanical Tests on Metallic Materials*, The Estimation of Uncertainties in Hardness Measurements, Project, No. SMT4-CT97-2165, UNCERT COP 14: 2000
- [9] GABAUER, W., BINDER O. *Abschätzung der Messunsicherheit in der Härteprüfung unter Verwendung der indirekten Kalibriermethode*, DVM Werkstoffprüfung, Tagungsband 2000, S. pp. 255-261
- [10] POLZIN, T., SCHWENK, D. *Estimation of Uncertainty of Hardness Testing; PC file for the determination*, *Materialprüfung*, **3**, 2002 (44), pp. 64-71

1) Corrected and reprinted:1995.

SRI LANKA STANDARDS INSTITUTION

The Sri Lanka Standards Institution (SLSI) is the National Standards Organization of Sri Lanka established under the Sri Lanka Standards Institution Act No. 6 of 1984 which repealed and replaced the Bureau of Ceylon Standards Act No. 38 of 1964. The Institution functions under the Ministry of Science & Technology.

The principal objects of the Institution as set out in the Act are to prepare standards and promote their adoption, to provide facilities for examination and testing of products, to operate a Certification Marks Scheme, to certify the quality of products meant for local consumption or exports and to promote standardization and quality control by educational, consultancy and research activity.

The Institution is financed by Government grants, and by the income from the sale of its publications and other services offered for Industry and Business Sector. Financial and administrative control is vested in a Council appointed in accordance with the provisions of the Act.

The development and formulation of National Standards is carried out by Technical Experts and representatives of other interest groups, assisted by the permanent officers of the Institution. These Technical Committees are appointed under the purview of the Sectoral Committees which in turn are appointed by the Council. The Sectoral Committees give the final Technical approval for the Draft National Standards prior to the approval by the Council of the SLSI.

All members of the Technical and Sectoral Committees render their services in an honorary capacity. In this process the Institution endeavours to ensure adequate representation of all view points.

In the International field the Institution represents Sri Lanka in the International Organization for Standardization (ISO), and participates in such fields of standardization as are of special interest to Sri Lanka.

SLS CERTIFICATION MARK

The Sri Lanka Standards Institution is the owner of the registered certification mark shown below. Beneath the mark, the number of the Sri Lanka Standard relevant to the product is indicated. This mark may be used only by those who have obtained permits under the SLS certification marks scheme. The presence of this mark on or in relation to a product conveys the assurance that they have been produced to comply with the requirements of the relevant Sri Lanka Standard under a well designed system of quality control inspection and testing operated by the manufacturer and supervised by the SLSI which includes surveillance inspection of the factory, testing of both factory and market samples.

Further particulars of the terms and conditions of the permit may be obtained from the Sri Lanka Standards Institution, 17, Victoria Place, Elvitigala Mawatha, Colombo 08.

