

SRI LANKA STANDARD
SLS ISO 12468-1 : 2016
UDC 699.81:614.841

EXTERNAL EXPOSURE OF ROOFS TO FIRE -
PART 1 : TEST METHOD

SRI LANKA STANDARDS INSTITUTION

Sri Lanka Standard
EXTERNAL EXPOSURE OF ROOFS TO FIRE –
PART 1 : TEST METHOD

SLS ISO 12468-1 : 2016
(ISO 12468-1 : 2013)

Gr. M

Copyright Reserved
SRI LANKA STANDARDS INSTITUTION
No. 17, Victoria Place
Elvitigala Mawatha
Colombo 08
SRI LANKA

Sri Lanka Standards are subject to periodical revision in order to accommodate the progress made by industry. Suggestions for improvement will be recorded and brought to the notice of the Committees to which the revisions are entrusted.

This standard does not purport to include all the necessary provisions of a contract.

© SLSI 2016

All right reserved. Unless otherwise specified, no part of this publication may be reproduced or utilized in any form or by any means, electronic or mechanical, including photocopying and microfilm, without permission in writing from the SLSI.

Sri Lanka Standard
EXTERNAL EXPOSURE OF ROOFS TO FIRE -- PART 1: TEST METHOD

NATIONAL FOREWORD

This standard was approved by the Sectoral Committee on Building and Construction Materials and was authorized for adoption and publication as a Sri Lanka Standard by the Council of the Sri Lanka Standard Institution on 2016-07-22.

This Sri Lanka Standard is identical with **ISO 12468-1: 2013**, published by the International Organization for Standardization (**ISO**).

This Sri Lanka standard specifies a test method to determine the resistance of roofs to external exposure to fire.

TERMINOLOGY AND CONVENTIONS

The text of the International Standard has been accepted as suitable for publication as a Sri Lanka Standard. However, certain terminology and conventions are not identical with those used in Sri Lanka Standards.

Attention is therefore drawn to the following:

- a) Wherever the “International Standard” appear referring to this standard they should be interpreted as “Sri Lanka Standard”.
- b) Wherever page numbers are quoted, they are “**ISO**” page numbers.
- c) The coma has been used throughout as a decimal marker. In Sri Lanka Standards it is the current practice to use a full point on the base line as the decimal marker.

For the purpose of deciding whether a particular requirement of this standard is complied with, the final value, observed or calculated, expressing the result of a test method or observation shall be rounded off in accordance with **SLS 102**. The number of significant places retained in the rounded off value shall be the same as that of the specified value in this standard.

CROSS REFERENCES

There are no corresponding Sri Lanka Standards available for references given in Clause 2.

INTERNATIONAL
STANDARD

SLS ISO 12468-1:2016

ISO
12468-1

Second edition
2013-11-01

External exposure of roofs to fire —

Part 1:
Test method

Exposition des toitures à un feu extérieur —
Partie 1: Méthode d'essais



Reference number
ISO 12468-1:2013(E)

© ISO 2013



COPYRIGHT PROTECTED DOCUMENT

© ISO 2013

All rights reserved. Unless otherwise specified, no part of this publication may be reproduced or utilized otherwise in any form or by any means, electronic or mechanical, including photocopying, or posting on the internet or an intranet, without prior written permission. Permission can be requested from either ISO at the address below or ISO's member body in the country of the requester.

ISO copyright office
Case postale 56 • CH-1211 Geneva 20
Tel. + 41 22 749 01 11
Fax + 41 22 749 09 47
E-mail copyright@iso.org
Web www.iso.org

Published in Switzerland

Contents

Page

Foreword	iv
Introduction	v
1 Scope	1
2 Normative references	1
3 Terms and definitions	1
4 Symbols	3
5 Selection of test specimen pitch	3
6 Test specimens	3
6.1 General requirements.....	3
6.2 Selection of standard supporting elements.....	5
6.3 Positioning of joints.....	6
6.4 Edge detailing.....	7
7 Test equipment	7
7.1 Exposure levels.....	7
7.2 Brands.....	8
7.3 Wind.....	10
7.4 Radiation.....	11
7.5 Timing device.....	11
7.6 Calibration element.....	11
7.7 Specimen holder.....	11
7.8 Gas burner.....	15
7.9 Stand.....	17
8 Test conditions	17
8.1 Test environment.....	17
8.2 Calibration procedure.....	18
9 Conditioning and test preparation	18
9.1 Conditioning.....	18
9.2 Protection of the edges.....	19
10 Test procedure	19
10.1 General.....	19
10.2 Commencement of the test.....	19
10.3 Ignition and positioning of the brands.....	20
10.4 End of the test.....	21
10.5 Post-test examination.....	21
11 Observations and measurements	21
11.1 General.....	21
11.2 External fire spread.....	21
11.3 Fire penetration.....	21
11.4 Opening.....	21
11.5 Damage.....	22
12 Expression of test results	22
13 Test report	22
Annex A (normative) Direct field of application	24

Foreword

ISO (the International Organization for Standardization) is a worldwide federation of national standards bodies (ISO member bodies). The work of preparing International Standards is normally carried out through ISO technical committees. Each member body interested in a subject for which a technical committee has been established has the right to be represented on that committee. International organizations, governmental and non-governmental, in liaison with ISO, also take part in the work. ISO collaborates closely with the International Electrotechnical Commission (IEC) on all matters of electrotechnical standardization.

The procedures used to develop this document and those intended for its further maintenance are described in the ISO/IEC Directives, Part 1. In particular the different approval criteria needed for the different types of ISO documents should be noted. This document was drafted in accordance with the editorial rules of the ISO/IEC Directives, Part 2 (see www.iso.org/directives).

Attention is drawn to the possibility that some of the elements of this document may be the subject of patent rights. ISO shall not be held responsible for identifying any or all such patent rights. Details of any patent rights identified during the development of the document will be in the Introduction and/or on the ISO list of patent declarations received (see www.iso.org/patents).

Any trade name used in this document is information given for the convenience of users and does not constitute an endorsement.

For an explanation on the meaning of ISO specific terms and expressions related to conformity assessment, as well as information about ISO's adherence to the WTO principles in the Technical Barriers to Trade (TBT) see the following URL: Foreword - Supplementary information

The committee responsible for this document is ISO/TC 92, *Fire Safety*, Subcommittee SC 2, *Fire Containment*.

This second edition cancels and replaces the first edition (ISO 12468-1:2003), of which it constitutes a minor revision.

ISO 12468 consists of the following parts, under the general title *External exposure of roofs to fire*:

- *Part 1: Test method*
- *Part 2: Classification of roofs*
- *Part 3: Commentary*

Introduction

This part of ISO 12468 specifies a test method that relates to the effects of fires on roofs. The test method described in this part of ISO 12468 represents the effect of three levels of fire exposure.

- Level A: A large burning brand coming from an adjacent building and falling onto the roof. Level A considers the effects of wind and additional radiant heat.
- Level B: A medium burning brand coming from a fire in a neighbourhood and falling onto the roof. Level B considers the effect of wind but without additional radiant heat.
- Level C: A small burning brand transported by the wind from a remote fire and falling onto the roof. Level C considers the effect of wind but without additional radiant heat.

External exposure of roofs to fire —

Part 1: Test method

1 Scope

CAUTION — The attention of all persons concerned with managing and carrying out this fire test is drawn to the fact that fire testing may be hazardous and that there is a possibility that toxic and/or harmful smoke and gases may be evolved during the test. Mechanical and operational hazards may also arise during the construction of the test elements or structures, their testing, and disposal of test residues. An assessment of all potential hazards and risks to health shall be made and safety precautions shall be identified and provided. Written safety instructions shall be issued. Appropriate training shall be given to relevant personnel. Laboratory personnel shall ensure that they follow written safety instructions at all times.

This part of ISO 12468 specifies a test method to determine the resistance of roofs to external exposure to fire. This method evaluates the behaviour of the roof when exposed to three types of burning brands combined with wind and with or without heat radiation, concerning

- a) the fire spread across the external surface of the roof,
- b) the fire spread within the roof,
- c) the fire penetration, and
- d) the production of flaming droplets or debris falling through the roof, from the underside of the roof, or from the exposed surface.

2 Normative references

The following documents, in whole or in part, are normatively referenced in this document and are indispensable for its application. For dated references, only the edition cited applies. For undated references, the latest edition of the referenced document (including any amendments) applies.

ISO 13943, *Fire safety — Vocabulary*

3 Terms and definitions

For the purposes of this document, the terms and definitions given in ISO 13943 and the following apply.

3.1

assembly

fabrication of materials and/or composites

EXAMPLE Sandwich panels.

3.2

burned material

material that has been destroyed by combustion or pyrolysis

3.3

composite

combination of materials which are generally recognized in building construction as discrete entities

EXAMPLE Coated or laminated product such as roofing felt.

3.4

continuous deck

deck supporting the roof covering in which the gap between adjacent elements is not greater than 0,5 mm (5,0 mm in the case of wooden planks with plain edges)

3.5

damaged material

material that has been burned, melted, or otherwise visually changed by heat but does not include discoloration and soot deposits

3.6

exposed surface

external surface of the calibration element or of the specimen which is subject to the heat conditions

3.7

external fire spread

progression and extent of sustained flaming across the exposed surface of the specimen

3.8

fire penetration

any opening, sustained flaming, or glowing due to combustion on the underside that appears during the test and/or the occurrence of any flaming droplets or debris falling through the specimen or from the underside

Note 1 to entry: Charring or discoloration is not to be regarded as fire penetration.

3.9

fire spread within the roof

extent of burned material in each functional layer inside the specimen

3.10

flaming droplets or debris

burning material falling from or through the specimen that continues to burn on the floor for at least 5 s

3.11

internal damage

extent of damaged material in each functional layer inside the specimen

3.12

material

basic single substance or a uniformly dispersed mixture of substances

EXAMPLE Metal, stone, wood, bitumen, concrete, or mineral wool.

3.13

measuring zone

area of the specimen within which measurements are made

3.14

opening

any hole greater than 10 mm × 10 mm that appears during the test which penetrates completely through the specimen

3.15

product

material ([3.12](#)), *composite* ([3.3](#)), or *assembly* ([3.1](#)) about which information is required

3.16

profile pitch

repeating length between sections of a uniformly corrugated or undulating roof deck

3.17

roof system

covering and sealing systems including any insulating layers or vapour barriers with their supporting elements and roof lights or other closures for roof apertures that are intended to provide a weatherproof surface

Note 1 to entry: Elements with a slope greater than 70° are not considered as roofs in this part of ISO 12468.

3.18

roof covering

material (3.12) attached to the deck

3.19

specimen

representative section of the roof system prepared for the purpose of test

3.20

sustained flaming

flaming arising from an observed location, which persists for 5 s or longer

3.21

underside

bottom surface of the specimen

4 Symbols

Symbol	Description	Unit
$v_1, v_2, v_3, v_4, v_5, v_6, v_7$	Velocity of the air at the measuring points	metres per second (m/s)
α	Pitch (slope)	degrees (°)

5 Selection of test specimen pitch

Roof systems designed for only one pitch shall be tested at the actual design pitch.

Roof systems designed for more than one pitch shall be tested as follows:

- a) for pitch (α) less than 5°, test at zero pitch;
- b) for pitch (α) from 5° to 20°, test at 15°;
- c) for pitch (α) greater than 20°, test at 30°.

6 Test specimens

6.1 General requirements

For each level of fire exposure, two specimens shall be tested with dimensions measuring 1 200 mm ± 10 mm in width × 2 000 mm ± 10 mm in length for each test pitch. (See [Figures 1](#) and [2](#).) When this is not possible due to the size of the roof light or other closure, a larger specimen shall be used.

NOTE Roof lights cause difficulties due to their size, shape, composition, and fire behaviour. Further guidance on the testing of roof lights will be presented in the next revision of this part of ISO 12468.

The specimens shall be representative in all details of the roof in practice.

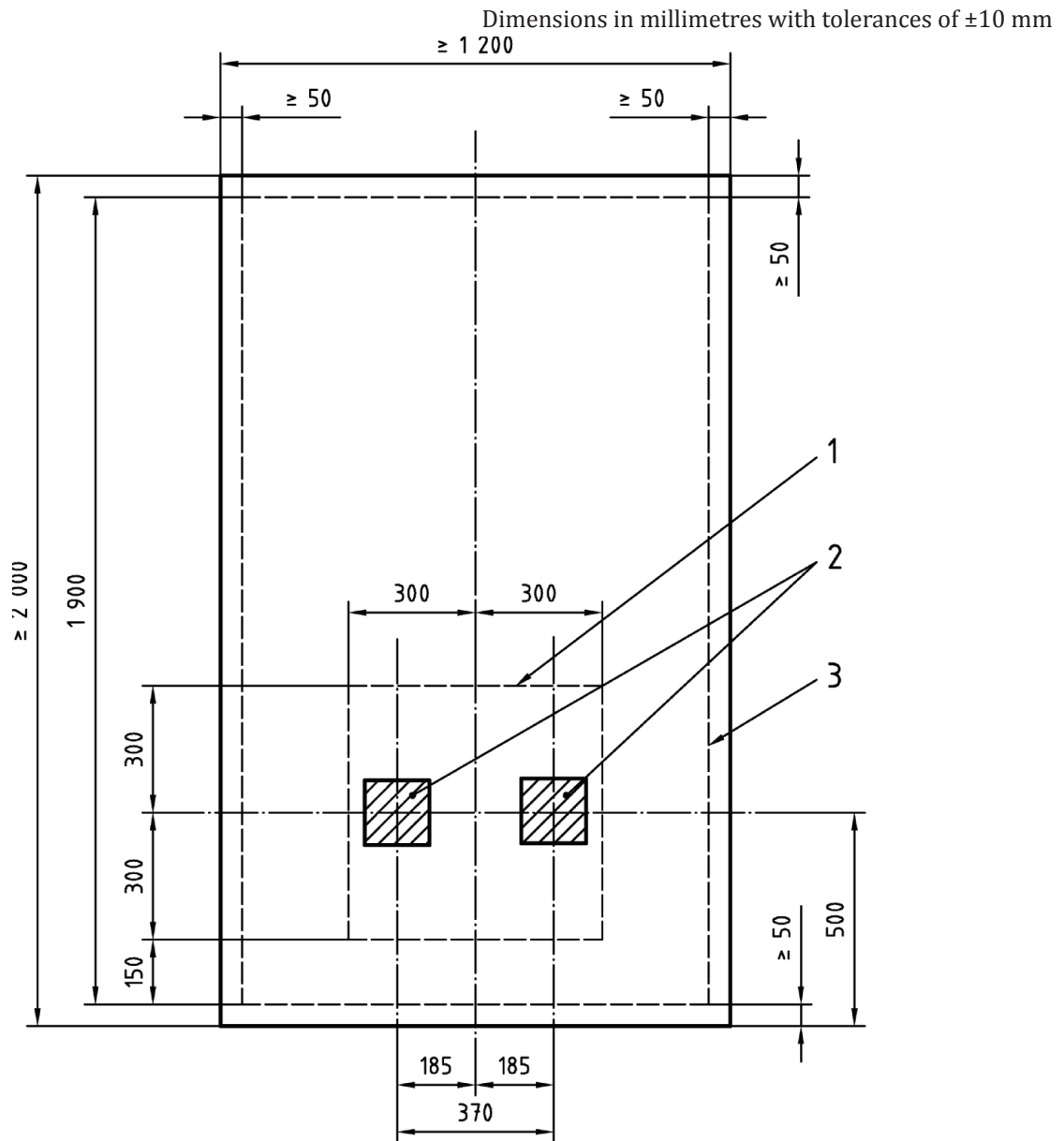
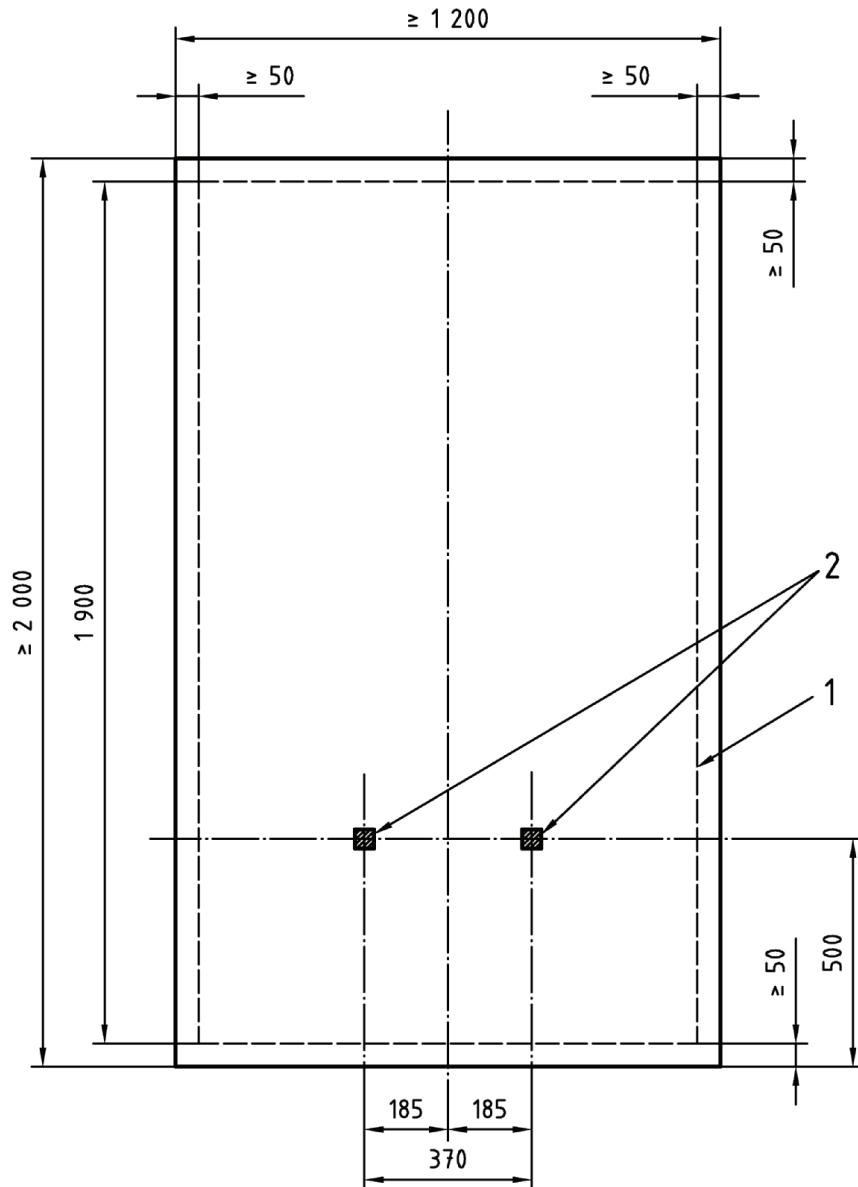

Figure 1 — Measuring zone and position of brands for Level A



Key

- 1 measuring zone
- 2 B brands or C brands

Figure 2 — Measuring zone and position of the brands for Level B or Level C

6.2 Selection of standard supporting elements

6.2.1 For continuous decks

6.2.1.1 General

The test deck shall be selected in accordance with the following:

- a) In the case of roof coverings intended to be installed over a continuous deck other than a profiled metal deck, a roof deck in accordance with [6.2.1.2](#) or [6.2.1.4](#) shall be used;

- b) If the materials will only be laid over a profiled metal deck, then a trapezoidal profiled metal deck, in accordance with [6.2.1.3](#), shall be used as the deck.

6.2.1.2 Wood particleboard decks

6.2.1.2.1 The wood particleboard shall consist of wood particles bonded with polymer adhesive (e.g. urea formaldehyde). This particleboard shall have a density of $680 \text{ kg/m}^3 \pm 50 \text{ kg/m}^3$ and shall not be treated with fire retardants.

6.2.1.2.2 A wood particleboard deck shall be constructed from planks 250 mm wide \times 13 mm \pm 1 mm thick running parallel to the eaves with plain edges and tightly butt jointed so that the gaps between planks do not exceed 0,5 mm.

6.2.1.2.3 If it is intended also to cover the case of decks made from wooden planks with plain edges, then these gaps shall be 5 mm \pm 0,5 mm.

6.2.1.3 Metal decks

The trapezoidal profiled metal deck shall be made of aluminium or steel (subject to the expected field of application) and have the width of the crown approximately equal to 50 % of the profile pitch and a trough depth of approximately 100 mm. The corrugations shall run parallel to the eaves and be open at the ends.

6.2.1.4 Other non-combustible decks

If roofing materials are intended to be laid only on continuous, non-combustible decks with a minimum thickness of 10 mm, then the test roof deck shall consist of 12 mm \pm 2 mm thick reinforced calcium silicate board (oven dry density $900 \text{ kg/m}^3 \pm 100 \text{ kg/m}^3$).

6.2.2 For non-continuous decks

The spacing of roof supports of any type shall be in accordance with the maximum permissible spans proposed by the manufacturer for the particular application but not exceeding the minimum dimensions specified for the specimen in [6.1](#).

6.3 Positioning of joints

6.3.1 General

The joints shall be representative of practical application. In the case of overlapping layers, the position of the joints shall be considered to be the edge of the upper layer.

6.3.2 Description of specimen types with respect to joints

Where the dimensions of the elements of any of the layers are such that it requires more than four pieces to cover the specimen, or if any of the layers are without joints, then the specimens shall be fabricated such that those layers are representative of actual field practice (see [Figures 3](#) and [4](#)).

Specimens are categorized by the following types:

- **Type 1:** Single central vertical joint in the top layer. Single horizontal joint in the top layer under position of the left brand. Single vertical joint in layer next to top layer under position of the right brand. Single vertical joint in insulation under position of the left brand [see [Figure 4 a](#)], Type 1];
- **Type 2:** Single vertical joint in the top layer under position of the right brand. Single vertical joint in layer next to insulation under position of the left brand [see [Figure 4 b](#)], Type 2];

- **Type 3:** One cross joint of the top layer under position of the right brand and, where possible according to the design of the product, a vertical joint in layer under top under the left brand [see [Figure 4 c](#)], Type 3];
- **Type 4:** Centre of one element of the top layer and, where possible according to the design of the product, a vertical joint of supporting deck, under position of the right brand and in insulation under the left brand [see [Figure 4 d](#)], Type 4].

6.3.3 Selection of the specimen types

Either specimen types, Types 1 and 2 or Types 3 and 4, shall be used for each test pitch and for each level of fire exposure.

6.4 Edge detailing

No special measures shall be taken by the sponsor to protect the edges of the specimen.

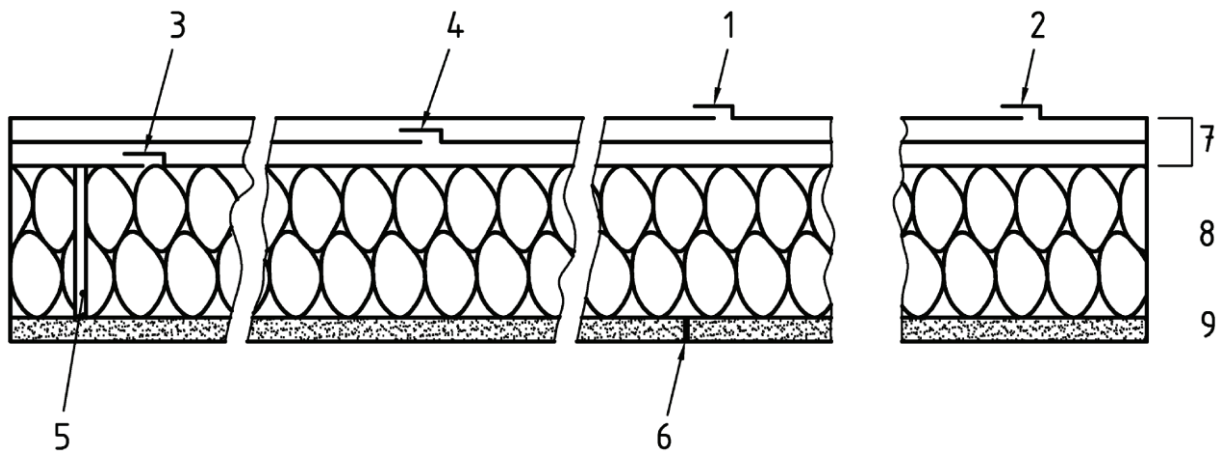

Key

- | | | | |
|---|-----------------------------------|---|-----------------------------------|
| 1 | vertical joint in top layer | 6 | vertical joint in supporting deck |
| 2 | horizontal joint in top layer | 7 | weathering layer |
| 3 | joint in layer next to insulation | 8 | insulation |
| 4 | joint in layer next to top layer | 9 | roof deck |
| 5 | joint in insulation | | |

Figure 3 — Identification of joints in a multilayer roof

7 Test equipment

7.1 Exposure levels

Three levels are defined:

- a) Level A consists of Brand A combined with wind and additional radiant heat;
- b) Level B consists of Brand B combined with wind and without any additional radiant heat;
- c) Level C consists of Brand C combined with wind and without any additional radiant heat.

The wind is identical for the Levels A, B, and C. The measuring zone, position of the brands, and position of the radiant panel are shown in [Figures 1](#) and [2](#).

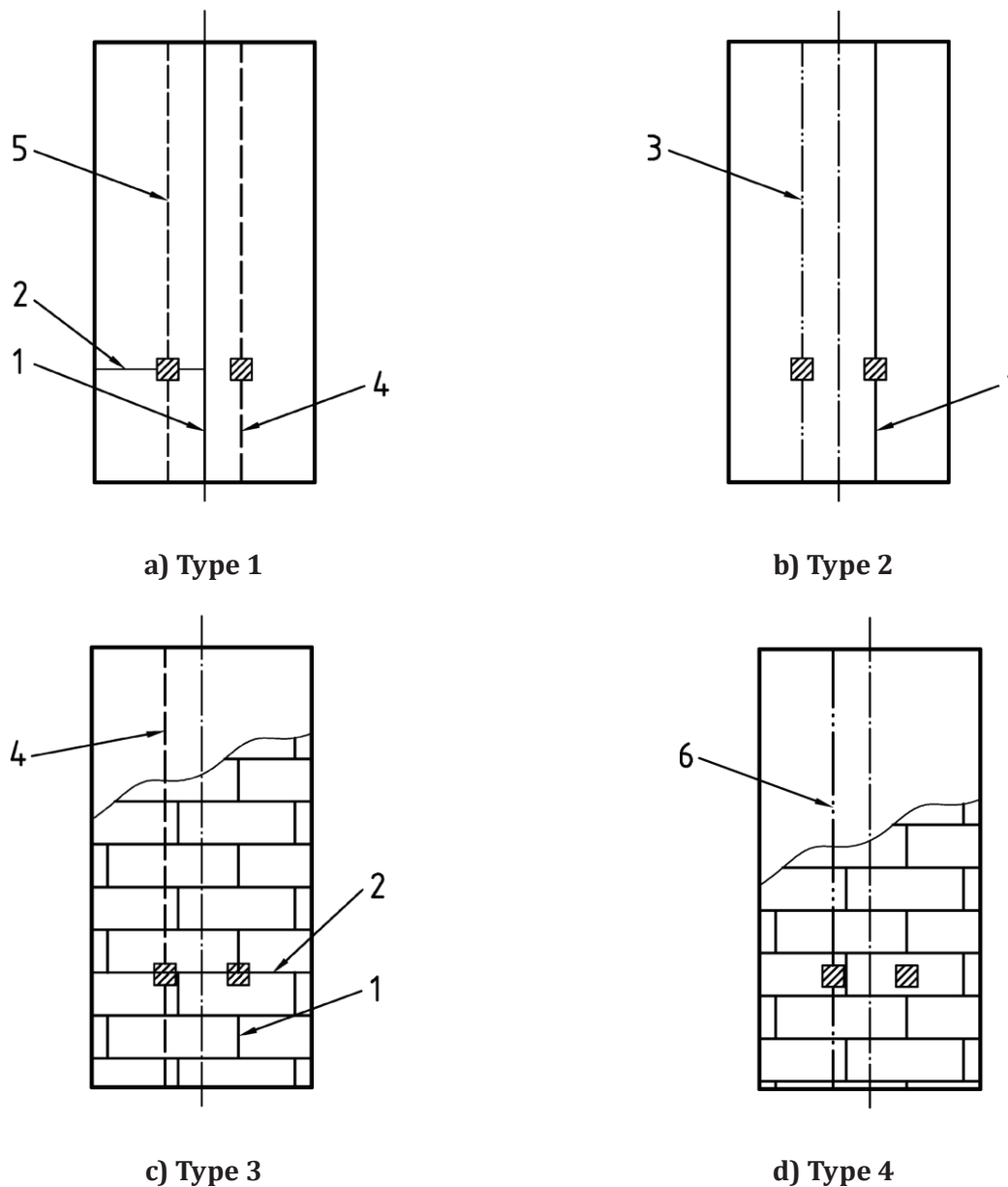

Key

- | | |
|-------------------------------------|-------------------------------------|
| 1 vertical joint in top layer | 4 joint in layer next to top layer |
| 2 horizontal joint in top layer | 5 joint in insulation |
| 3 joint in layer next to insulation | 6 vertical joint in supporting deck |

Figure 4 — Position of joints and types of specimens

7.2 Brands

7.2.1 General

Two brands are utilized for each specimen. The test brands shall be constructed from Beech (*Fagus salvatICA* or *Fagus grandifolia*) having an oven-dry density of $560 \text{ kg/m}^3 \pm 50 \text{ kg/m}^3$.

The mass of the finished brand following conditioning in an oven at 40 °C to 50 °C for at least 24 h shall be 33 g ± 5 g at the time of the test for Brand C, 155 g ± 10 g (less fasteners) at the time of the test for Brand B, and 550 g ± 50 g (less fasteners) at the time of the test for Brand A.

7.2.2 Brand A

Brand A shall consist of a grid of approximately 150 mm square and 57 mm deep, using nominally 19 mm × 19 mm × 150 mm strips of lumber, placed in three layers of six strips each, placed at right angles to adjacent layers and spaced equidistant from each other within the brand envelope. The strips shall be fastened to this configuration using light nails or staples (see [Figure 5](#)).

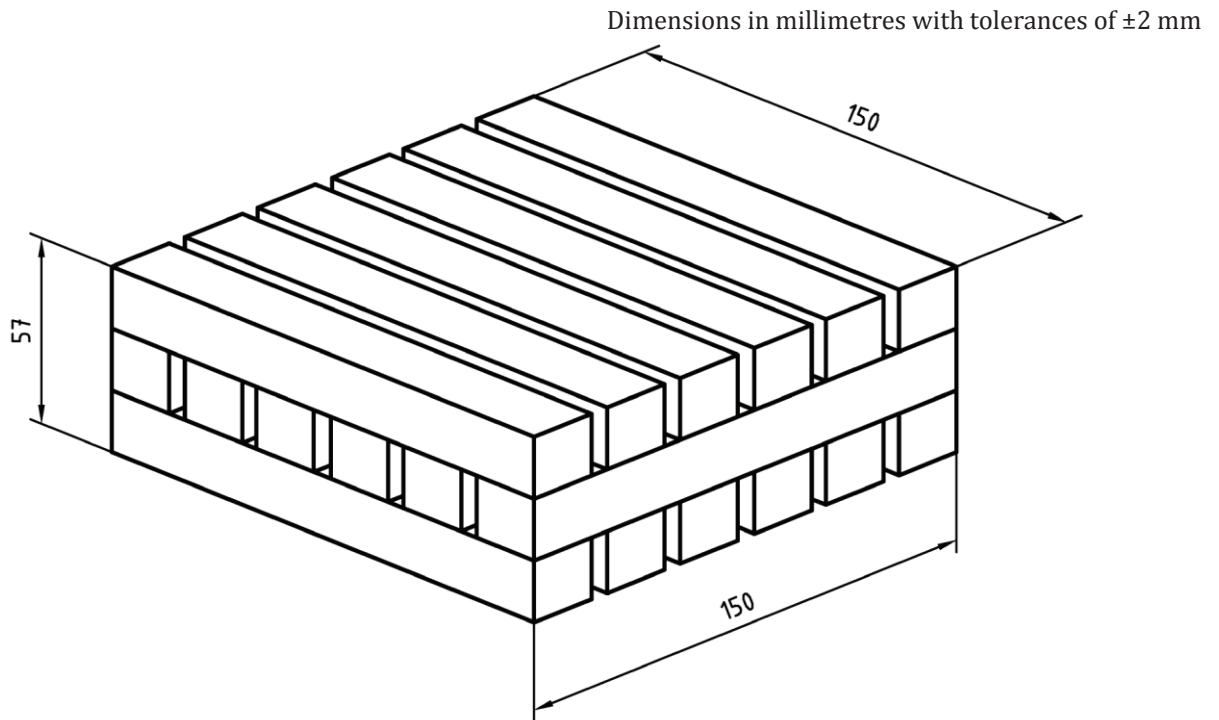

Figure 5 — Brand A

7.2.3 Brand B

Brand B shall consist of a grid of approximately 80 mm square and 57 mm deep, using nominally 19 mm × 19 mm × 80 mm strips of lumber, placed in three layers of three strips each, placed at right angles to adjacent layers and spaced equidistant from each other within the brand envelope. The strips shall be fastened to this configuration using light nails or staples (see [Figure 6](#)).

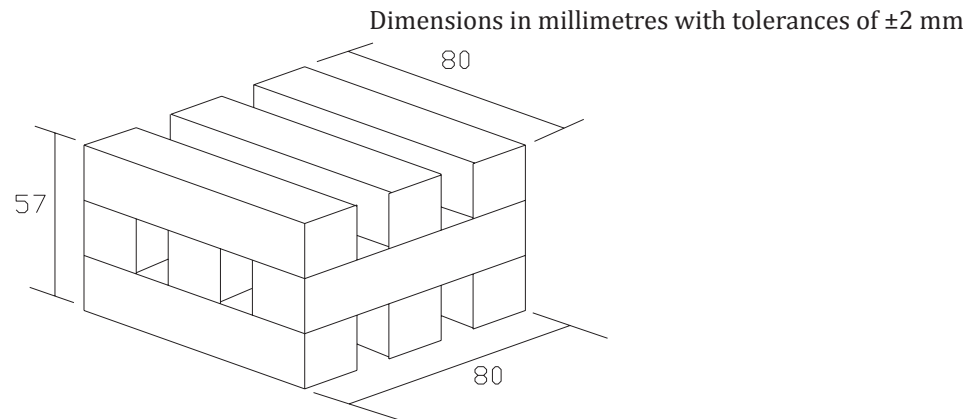

Figure 6 — Brand B

7.2.4 Brand C

Brand C shall consist of a piece of lumber $40\text{ mm} \times 40\text{ mm} \times 40\text{ mm}$ with a saw cut 3 mm wide, half the thickness of the brand across the centre of the top and bottom faces. The saw cuts on opposite face shall be at right angles to each other (see [Figure 7](#)).

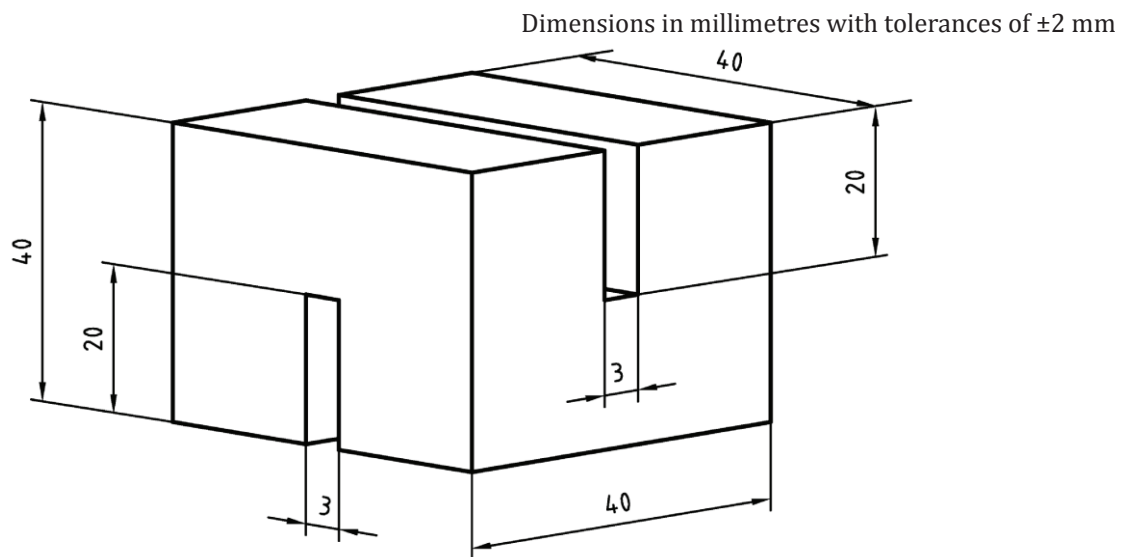

Figure 7 — Brand C

7.3 Wind

7.3.1 Apparatus

A wind-generating apparatus capable of applying air across the surface of the calibration element at a temperature of $20\text{ °C} \pm 15\text{ °C}$ and a velocity as defined in [8.2.3](#) shall be used. The apparatus shall have a control for the volume rate. The wind outlet section of the tube shall have a minimum dimension of 250 mm in height and $1\,000\text{ mm}$ in width. The minimum length of the duct shall be $1\,200\text{ mm}$. Baffles and flow smoothers shall be used to avoid turbulence of the flow pattern.

7.3.2 Air velocity

A vane anemometer with a diameter no greater than 25 mm shall be used to measure the air velocity. The instrument shall integrate the average value of the air velocity for a period of 10 s to 30 s at the respective positions (see [Figure 8](#)). The air velocity shall be established parallel to the surface and in the direction of the longitudinal axis of the calibration element.

So as to minimize the disturbance of the flow pattern in the region of the measuring zone, a supporting device shall be used.

7.3.3 Eave

A simulated eave shall be installed in front of the test specimen to prevent air from flowing underneath the test specimen.

This shall be done in a way so as not to interfere with or obstruct material flowing or falling from the roof surface (see [Figures 9](#) and [10](#)).

7.4 Radiation

A radiant panel of $600 \text{ mm} \pm 10 \text{ mm} \times 600 \text{ mm} \pm 10 \text{ mm}$ capable of being mounted in a plane parallel to the surface of the specimen and at a distance of $500 \text{ mm} \pm 10 \text{ mm}$ above it shall be provided.

The radiant panel shall be capable of providing a heat flux distribution on the surface of the specimen as defined in [8.2.4](#), with wind. A flux meter having accuracy equal to or better than 5 % of the target value shall measure the total heat flux.

7.5 Timing device

A timing device with an accuracy better than or equal to 5 s over 1 h shall be provided for the recording of the sequence of events during each test.

7.6 Calibration element

The calibration element consists of a smooth, flat $12 \text{ mm} \pm 2 \text{ mm}$ thick sheet of calcium silicate material having the dimension $1\,200 \text{ mm} \times 2\,000 \text{ mm}$ and a density of $900 \text{ kg/m}^3 \pm 100 \text{ kg/m}^3$.

A 25-mm-diameter Schmit Boelter heat flux meter, with a design range of $(0 - 50) \text{ kW/m}^2$ shall be used to establish the heat flux distribution on the surface of the calibration element. The target receiving radiation from the radiant panels shall be flat, circular, and coated with a durable matt black finish. The target shall be water cooled. Radiation shall not pass through any window before reaching the target. The instrument shall be robust, simple to set up and use, and stable in calibration. The instrument shall have an accuracy of within $\pm 3 \%$ and a repeatability within 0.5 %.

NOTE The calibration of the heat flux meter shall be checked by comparison with two instruments of the same type as the working heat flux meter and of similar range, held as reference standards and not used for any other purpose. One of the reference standards shall be fully calibrated at a competent laboratory at yearly intervals.

7.7 Specimen holder

The specimen holder shall be capable of presenting the specimen to the airflow at the required pitch.

Dimensions in millimetres

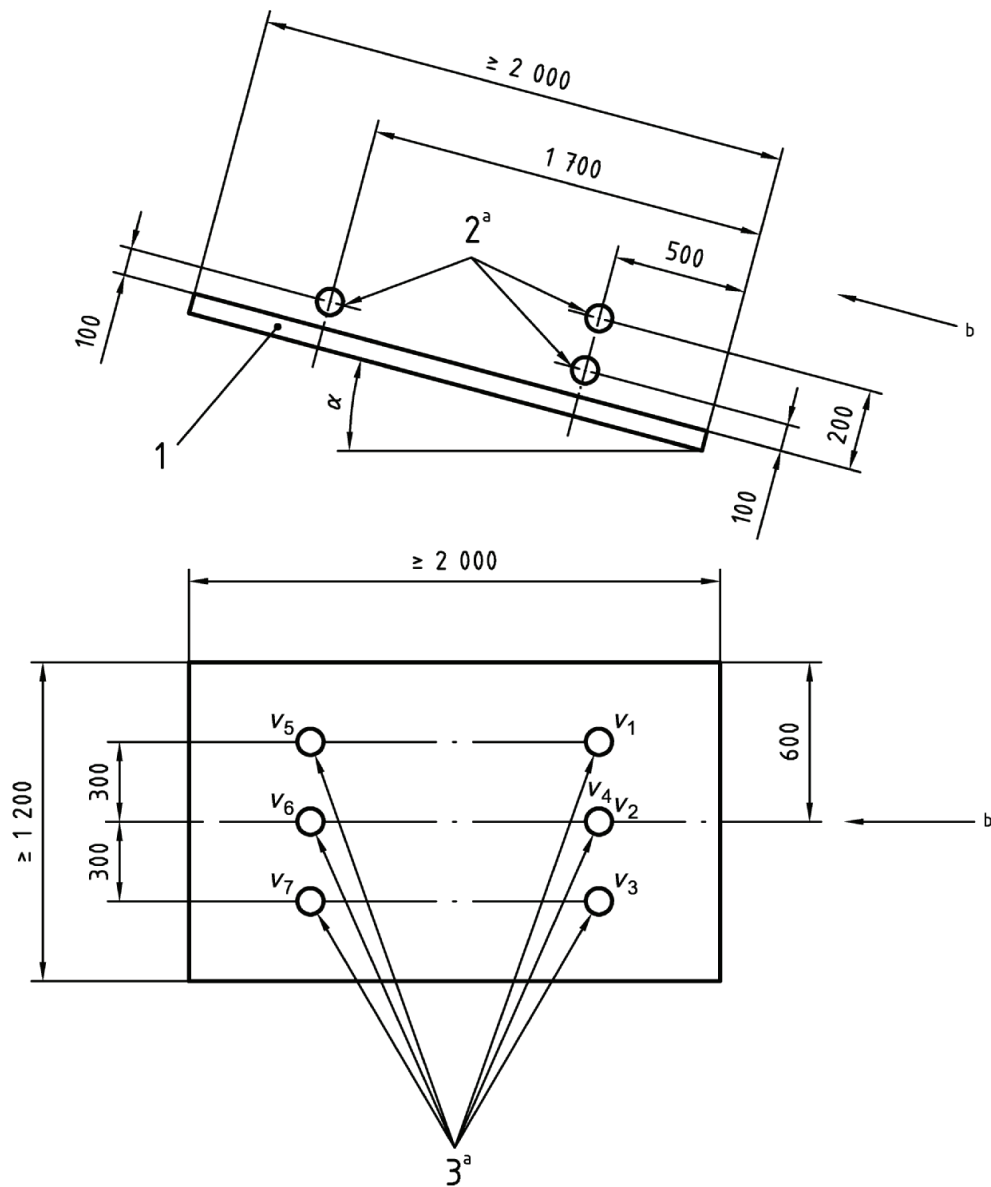

Key

- 1 calibration element
- 2^a anemometer location (side view)
- 3^a anemometer location (plan view)
- a All dimensions specifying the positions of the anemometer are in millimetres with tolerances of ± 5 mm. See [8.2.3](#).
- b Air flow.

Figure 8 — Positions for air velocity measurement

Dimensions in millimetres

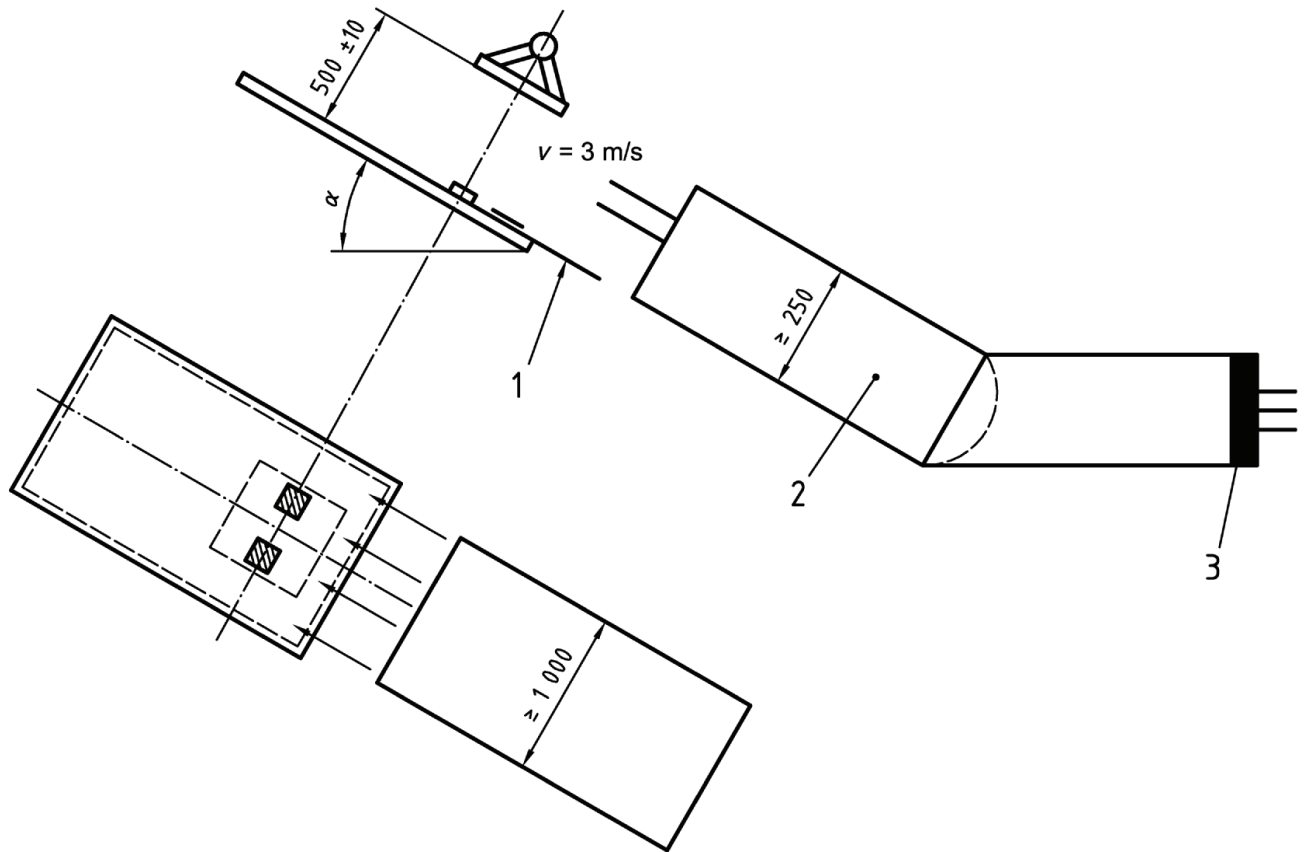

Key

- 1 eave
- 2 wind apparatus
- 3 filter

Figure 9 — Examples for general test arrangement for Level A

Dimensions in millimetres

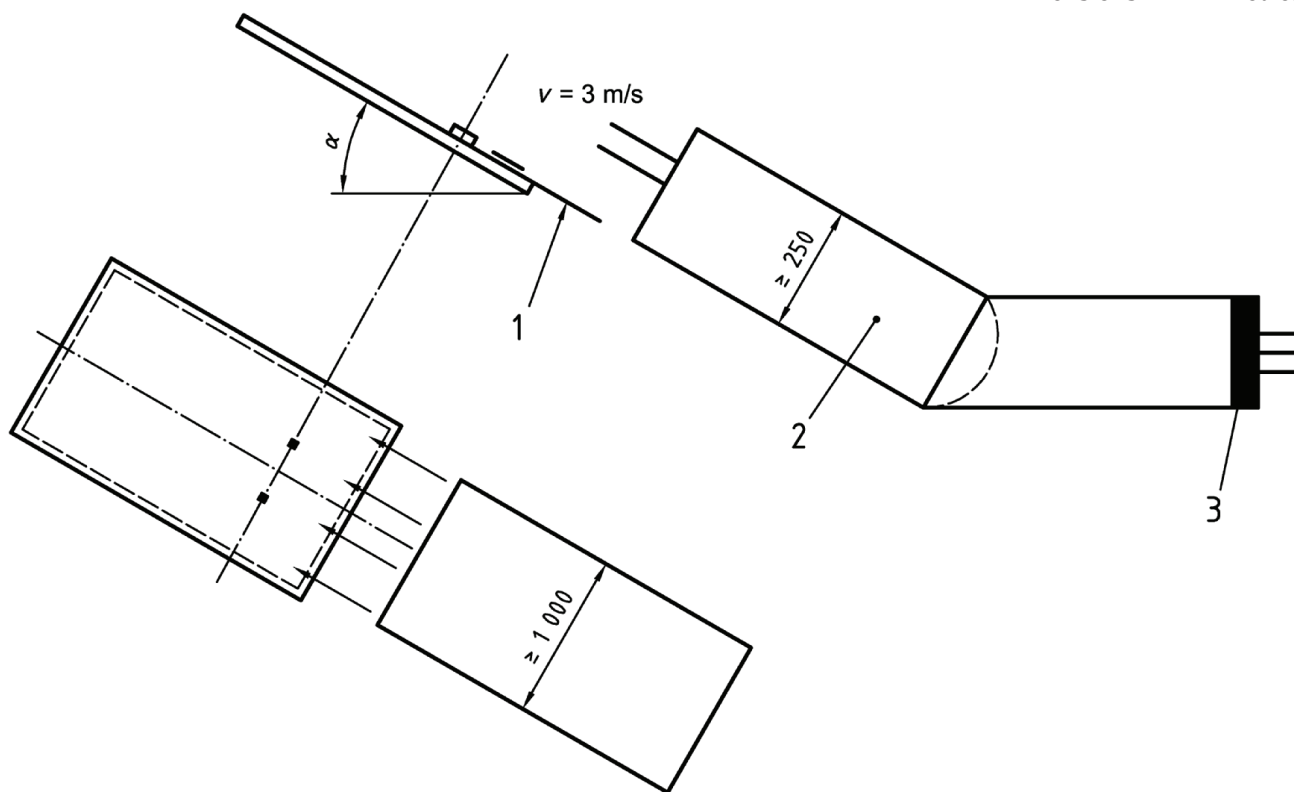

Key

- 1 eave
- 2 wind apparatus
- 3 filter

Figure 10 — Examples for general test arrangement for Level B and Level C

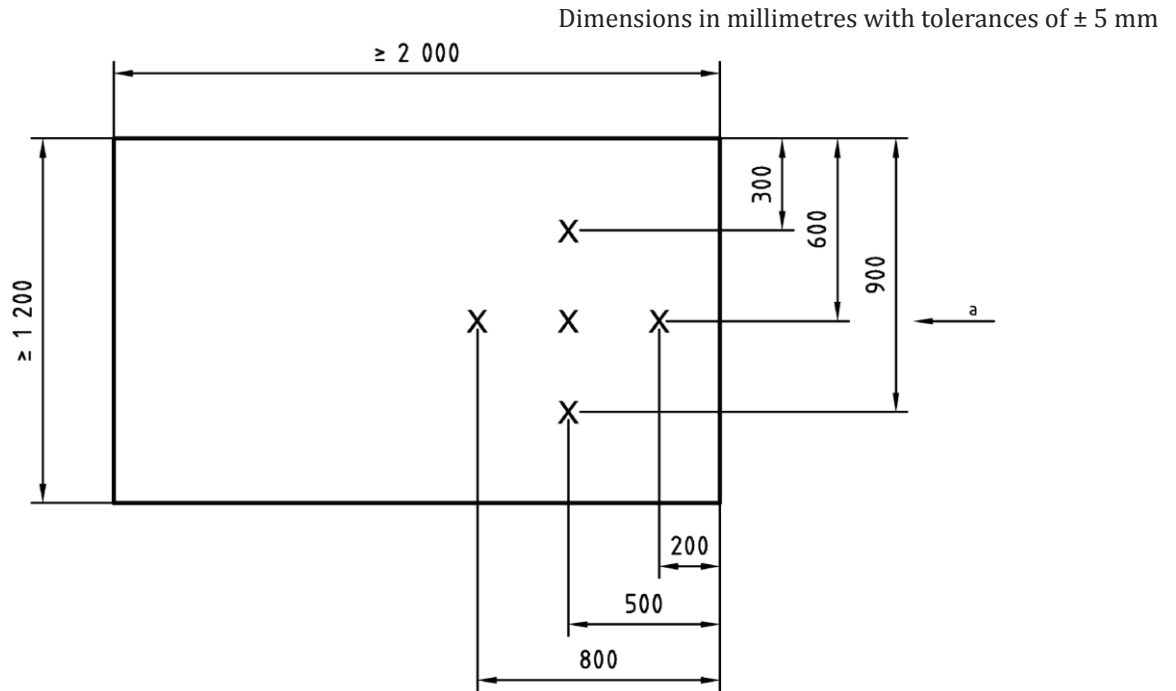

Key

X positions for heat flux measurement

a Air flow.

Figure 11 — Positions for heat flux measurements during calibration

7.8 Gas burner

A gas burner of such size that during the procedure of ignition, the brands are enveloped in the burner flame. The burner shall be shielded from draughts. The flame temperature of the igniting flame shall be $900\text{ °C} \pm 50\text{ °C}$ measured $60\text{ mm} \pm 5\text{ mm}$ above the top of the burner. An example of a suitable burner is shown in [Figures 12](#) and [13](#).

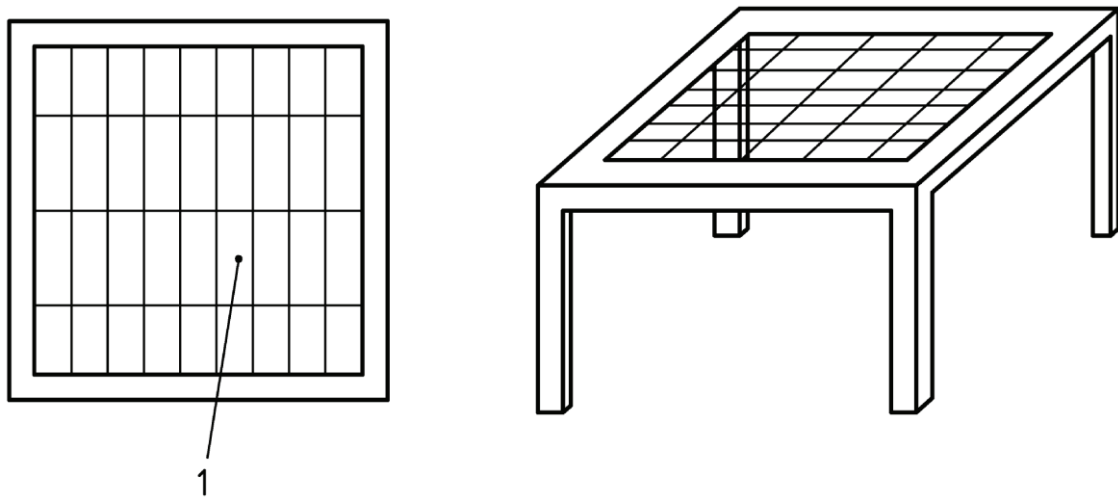

a) Stand

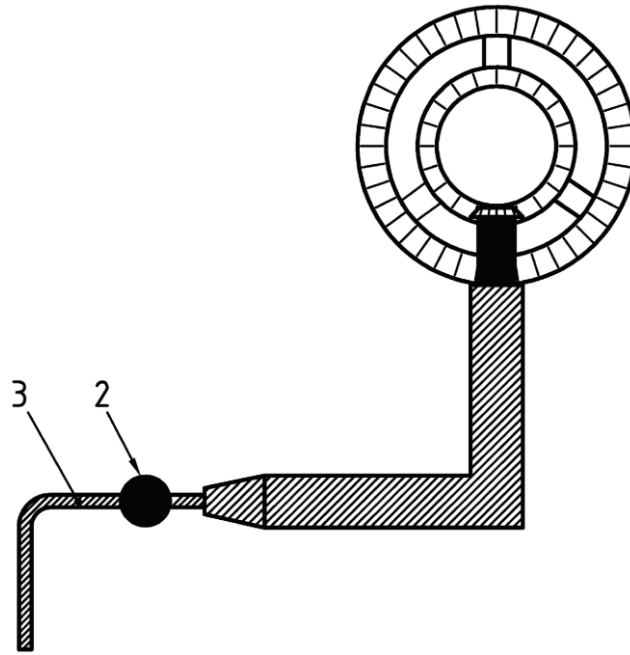

b) Burner

Key

- 1 wire bars
- 2 valve
- 3 gas supply

Figure 12 — Example of suitable stand and burner

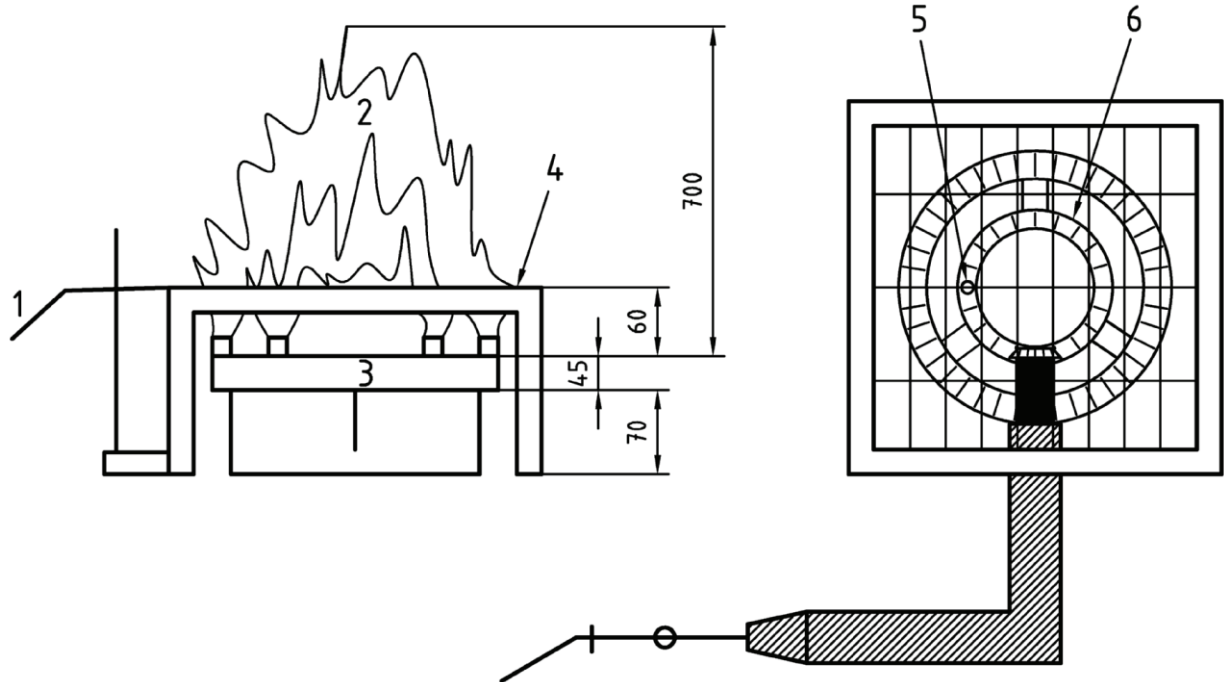

Key

- 1 thermocouple
- 2 flame
- 3 burner
- 4 stand
- 5 stacked thermocouple 3 mm off centre
- 6 inner ring
- a General tolerances ± 5 mm.
- b Thermocouple is directly over the inner ring, just 3 mm off centre. The thermocouple is $63 \text{ mm} \pm 2 \text{ mm}$ above the inner ring.

Figure 13 — Example of suitable installation of stand and burner with thermocouple

7.9 Stand

A stand designed to support the brand during the period of ignition at a distance of $60 \text{ mm} \pm 5 \text{ mm}$ above the top of the burner shall be provided. An example of a suitable stand is shown in [Figures 12](#) and [13](#).

8 Test conditions

8.1 Test environment

Tests shall be carried out in a draught free enclosure of no less than 150 m^3 in volume. The lower edge of the specimen shall be $750 \text{ mm} \pm 250 \text{ mm}$ above the floor. The floor can be simulated by a horizontal platform of non-combustible material located at the correct height with respect to the lower edge of the specimen. The temperature in the enclosure shall be $20 \text{ }^\circ\text{C} \pm 15 \text{ }^\circ\text{C}$ prior to the fire test. If any measures are taken to remove products of combustion from the test laboratory, they shall be in operation during the calibration period and maintained during the test.

8.2 Calibration procedure

8.2.1 Frequency

The interval between calibration and test shall not exceed seven days. A new calibration shall be done each time the pitch is changed.

8.2.2 Method

With the non-combustible calibration element placed on it, the test specimen holder shall be elevated to its required pitch with respect to the horizontal.

8.2.3 Wind

Before igniting the radiant panel, a uniform airflow shall be established using the equipment described in [7.3.1](#).

The anemometer shall be positioned at seven locations.

Four locations shall be $500 \text{ mm} \pm 5 \text{ mm}$ from the bottom edge with three locations (v_1 , v_2 , and v_3) $100 \text{ mm} \pm 5 \text{ mm}$ above the calibration element with v_2 on the central axis and v_1 and v_3 located $300 \text{ mm} \pm 5 \text{ mm}$ on either side of the central axis and one location (v_4) on the central axis $200 \text{ mm} \pm 5 \text{ mm}$ above the calibration element. See [Figure 8](#).

Three locations (v_5 , v_6 , and v_7) shall be $1\,700 \text{ mm} \pm 5 \text{ mm}$ from the bottom edge and $100 \text{ mm} \pm 5 \text{ mm}$ above the calibration element. v_6 shall be on the central axis and v_5 and v_7 located $300 \text{ mm} \pm 5 \text{ mm}$ on either side of the central axis. See [Figure 8](#).

The target velocities are as follows:

- $v_1 = v_2 = v_3 = v_4 = (3,0 \pm 0,2) \text{ m/s}$
- $v_6 > 2,0 \text{ m/s}$
- $|v_5 - v_7| < 0,2 \text{ m/s}$

The temperature and relative humidity of the air used in generating the wind shall be measured and recorded to the nearest degree Celsius and percent relative humidity respectively.

8.2.4 Radiation

With the calibration element in position and the wind speed correctly set, the radiant panel shall be adjusted such that the flux at the central position is $(12,5 \pm 0,5) \text{ kW/m}^2$ and the minimum at the four locations on the major axes, as depicted in [Figure 11](#), is $(10 \pm 0,5) \text{ kW/m}^2$.

9 Conditioning and test preparation

9.1 Conditioning

At the time of the test, the moisture content of the specimen shall approximate the condition expected in normal service. If the specimen contains or is liable to absorb moisture, it shall not be tested until it has reached an air-dry condition. This condition shall be considered as that which would be established at equilibrium resulting from drying in an ambient atmosphere of 50 % relative humidity at 23 °C.

One method of achieving this is to store the specimen in an enclosure (minimum 15 °C, maximum relative humidity 75 %) for the time needed to reach moisture equilibrium. This is attained when two successive weighing operations carried out at an interval of 24 h do not differ by more than 0,1 % of the mass of the specimen.

Accelerated conditioning is permissible provided the method does not alter the properties of component materials. In general, high temperature conditioning should be below the temperature critical for the materials.

If, after conditioning, it is not possible to achieve the specified moisture content, but the design strength of the absorptive component has been attained, the specimen may then be subjected to the fire test.

Representative samples may be used for moisture content determination and conditioned with the specimens. These should be so constructed as to represent the loss of water vapour from the specimen by having similar thickness and exposed faces.

Standards for specific elements may contain additional or alternative rules for obtaining moisture equilibrium.

9.2 Protection of the edges

It may be necessary for the laboratory to take measures to prevent failure due to flames passing around the edges of the specimen. These measures should not affect the fire behaviour within the measuring zone or within the specimen and shall be fully described in the test report (see [Figure 1](#)). If it is necessary to protect the lower edge, this shall be done in a way so as not to interfere with or obstruct material flowing or falling from the roof surface.

10 Test procedure

10.1 General

For non-flat surfaces (e.g. corrugated products or tiles), the uppermost part of the specimen shall be used as the reference plane for determining the position of the specimen with respect to the radiant panel and wind machine.

10.2 Commencement of the test

10.2.1 Test at Level A

The wind velocity and radiant heat flux shall be controlled using the same settings as for the most recent calibration. The laboratory conditions shall be as specified in [8.1](#).

The test procedure is as follows:

- a) Make sure the wind machine is operating.
- b) Ignite the radiant panel and allow it to stabilize.
- c) Place the specimen at the required slope on the specimen holder.
- d) Ignite both brands (see [10.3.2.1](#)).
- e) Move the specimen into the correct position with respect to the radiant panel and wind machine 3,5 min after commencement of ignition of the brands.
- f) Place the brands on the specimen immediately after they are ignited.
- g) Start the timing device the moment the brands are placed on the specimen. This is considered the start of the test.

10.2.2 Test at Level B or Level C

The wind velocity shall be controlled using the same settings as for the most recent calibration. The laboratory conditions shall be as specified in [8.1](#).

The test procedure is as follows:

- a) Make sure the wind machine is operating.
- b) Place the specimen at the required slope on the specimen holder.
- c) Ignite both brands (see [10.3.3.1](#)).
- d) Place the brands on the specimen immediately after they are ignited.
- e) Start the timing device the moment the brands are placed on the specimen. This is considered the start of the test.

10.3 Ignition and positioning of the brands

10.3.1 General

The brands shall be ignited and positioned in accordance with the procedures given in [10.3.2](#) to [10.3.3](#).

The general tolerance for the position of the brands is ± 10 mm.

10.3.2 Brand A

10.3.2.1 Ignition

Expose each Brand A to the flame for $240 \text{ s} \pm 10 \text{ s}$, during which time they are to be rotated to present each surface to the flame as follows:

- a) each $150 \text{ mm} \times 150 \text{ mm}$ face for 30 s;
- b) each $57 \text{ mm} \times 150 \text{ mm}$ face for 30 s;
- c) each $150 \text{ mm} \times 150 \text{ mm}$ face again for 30 s.

10.3.2.2 Positioning

Position the brands with their centre 500 mm from the lower edge of the specimen and 370 mm apart and equidistant from the specimen's longitudinal centreline. Orient the brands such that the top strips in one brand are parallel and in the other brand normal to the bottom edge of the test specimen. The position of the brands may be maintained by wires anchored to the edges of the specimen. If the roof surface is not uniform, place the brands 500 mm from the lower edge and in positions at least 200 mm on either side of the longitudinal centreline. The exact positions are determined by the test laboratory as those expected to give the most onerous result (see [Figure 1](#)).

10.3.3 Brand B or Brand C

10.3.3.1 Ignition

Expose each Brand B and Brand C to the flame for $120 \text{ s} \pm 10 \text{ s}$, during which time they are to be rotated so as to present each of the grooved faces to the flame for 60 s.

10.3.3.2 Positioning

Position the B and C Brand with their centre 500 mm from the lower edge of the specimen and 370 mm apart and equidistant from the specimen's longitudinal centreline. Wires anchored to the edges of the specimen may maintain the position of the brands. If the roof surface is not uniform, the brands shall be placed 500 mm from the lower edge and in positions at least 200 mm on either side of the longitudinal centreline. The test laboratory shall determine the exact position expected to give the most onerous result (see [Figure 2](#)).

10.4 End of the test

Terminate the test and extinguish any visible flames by using water, taking care not to excessively damage the specimen when any of the following events occur:

- a) there is a risk of safety to personnel or impending damage to equipment;
- b) fire penetration;
- c) after a period of 30 min has elapsed from the commencement of the test.

10.5 Post-test examination

Commence post-test examination of the specimen within 30 min after the end of the test.

11 Observations and measurements

11.1 General

During and/or after the test, the test parameters as specified in [11.2](#) up to [11.5](#) shall be observed, measured, and recorded for each specimen, taking into account the following.

- a) dimensions shall be expressed in millimetres;
- b) times shall be measured from the commencement of the test;
- c) progress of sustained flaming shall be estimated with respect to the base of the flame in contact with the exposed surface and not with respect to the flame envelope.

If the roof is a flat roof with a pitch of 0°, then the concept of upwards and downwards is replaced by the direction of the wind and the opposite direction respectively.

11.2 External fire spread

11.2.1 Record the time necessary for the sustained flame to progress upwards 100 mm, 300 mm, 500 mm, 700 mm, 900 mm, 1 100 mm, and 1 300 mm from any of the upper edges of the projection of the brands on the exposed surface and when it reaches the upper edge ([3.7](#)) of the measuring zone ([3.13](#)).

11.2.2 Record the time of occurrence and description of any burning material (flaming droplets or debris, see [3.10](#)) falling from the exposed surface.

11.2.3 Record the extent of external fire spread upwards and downwards during the test, expressed as the maximum burned length from the edges of the projection of the brands onto the exposed surface, measured at the end of the test.

11.3 Fire penetration

11.3.1 Record the time and nature of fire penetration ([3.8](#)), if this has occurred.

11.3.2 Record the time of occurrence and description of any flaming droplets or debris ([3.10](#)) falling from the underside of the specimen.

11.4 Opening

Record the time of occurrence and dimensions of openings ([3.14](#)) and the dimension of the openings when the test is terminated.

11.5 Damage

11.5.1 Record the extent and nature of internal damage (3.11) upwards, downwards, and laterally, measured during the post-test examination from the edges of the projection of the brands.

11.5.2 Record the maximum length of burned material (3.2) upwards, downwards, and laterally in each functional layer (see 3.11), measured during the post-test examination from the edges of the projection of the brands.

12 Expression of test results

The expression of test results shall include fire penetration, external fire spread, falling of flaming droplets or debris, and internal damage. These results are used for classification as defined in ISO 12468-2.

13 Test report

The test report shall include the following information:

- a) a reference to this part of ISO 12468 (i.e. ISO 12468-1);
- b) the name of the test laboratory and the date of the test;
- c) the names of the sponsor, the product, and the manufacturer of the specimen and its component parts, if known. If unknown, this shall be stated;
- d) a statement concerning the degree of supervision exercised by the laboratory during specimen fabrication;
- e) a full description of the test roof deck (This shall include the method of attaching the roof covering e.g. nails, fixings, spacing, adhesives, the density or mass per unit area of materials and, where applicable, moisture content of the materials used. This shall also include the building materials' classes with reference to standards, the nature and quantity of adhesives, or their rate of application if necessary to define the product uniquely.);
- f) a description of any measures taken to prevent the flames passing around the edges (see 9.2);
- g) the pitch at which the specimen was tested;
- h) the room temperature, expressed in degree Celsius, at the beginning of the test;
- i) all information relevant to the selected level of fire exposure A, B, or C, the selected test procedures, the product(s) tested, and the results obtained. Photographs are recommended to illustrate the test results;
- j) observations and measurements during and after the test including but not limited to:
 - 1) external fire spread, expressed by the time of occurrence, in minutes and seconds, at distances of 100 mm, 300 mm, 500 mm, 700 mm, 900 mm, 1 100 mm, and 1 300 mm, and the upper edge of the measuring zone, in an upwards direction;
 - 2) time that any flaming material falls from the surface of the roof (see 3.10);
 - 3) the burned length upwards, downwards, and laterally as measured from the nearest edge of the projection of the brands (see 11.5);
 - 4) the time, expressed in minutes and seconds, at which fire penetration occurred and a description of the type of penetration, i.e. sustained flaming or glowing on the underside, flaming droplets or debris falling through the specimen or from the underside, or the creation of an opening;

- 5) a description of the damage to the test specimen including:
 - i) the extent of non-flaming propagation (smouldering and glowing);
 - ii) the extent of internal damage (see [3.11](#)) upwards, downwards, and laterally;
 - iii) the maximum length of burned material (see [3.2](#)) upwards, downwards, and laterally in each functional layer;
- 6) time at which the test is terminated and the reason for termination (see [10.4](#));
- k) the field of application for which the report is valid as defined in [Annex A](#).

Annex A (normative)

Direct field of application

A.1 Pitch

Test results obtained in a horizontal position shall apply to the roof system having pitches of less than 5°.

Test results obtained at 15° shall apply to the roof system having pitches from 5° to 20°.

Test results obtained at 30° shall apply to the roof system having pitches greater than 20° up to 70°.

Pitches greater than 70° are outside the scope of this International Standard.

When two tests are carried out at 0° and 30° and give the same classification, that classification applies to any pitch from 0° to 70°.

Test results obtained at an alternative specified pitch shall apply to the roof system for that pitch only.

A.2 Nature of the deck

A.2.1 Test with standard supporting decks

A.2.1.1 Test results obtained with standard supporting decks shall apply to all systems with the same components (including the thickness) installed in the same way, but with different decks as follows.

A.2.1.2 Test results obtained with a wood particleboard deck as defined in [6.2.1.1](#), with gaps between planks not exceeding 0,5 mm, shall apply to

- a) any wooden continuous deck with a minimum thickness of 12 mm and with gaps not exceeding 0,5 mm and
- b) any non-combustible continuous deck with a minimum of 10 mm.

A.2.1.3 Test results obtained with a wood particleboard deck as defined in [6.2.1.1](#), with gaps of 5,0 mm ± 0,5 mm between planks, shall apply to

- a) any wooden continuous deck (see [3.4](#)),
- b) any continuous deck made from wooden planks with plain edges, and
- c) any non-combustible deck with gaps not exceeding 5,0 mm.

A.2.1.4 Test results obtained with a trapezoidal profiled steel deck as defined in [6.2.1.2](#) shall apply to

- a) any profiled steel deck and
- b) any non-combustible continuous deck with a minimum thickness of 10 mm.

A.2.1.5 Test results obtained with a trapezoidal aluminium deck as defined in [6.2.1.2](#) shall apply to

- a) any profiled aluminium deck with thickness greater than or equal to the tested thickness,

- b) any profiled steel deck, and
- c) any non-combustible continuous deck with a minimum thickness of 10 mm.

A.2.1.6 Test results obtained with a reinforced calcium silicate board as defined in [6.2.1.3](#) shall apply to any non-combustible continuous deck with a minimum thickness of 10 mm.

A.2.2 Test with alternative supporting deck

Test results obtained with an alternative supporting deck shall apply only to that roof system.

A.3 Level of fire exposure

Any roof system, which satisfies requirements related to Level A, is deemed to satisfy the same requirements at Level B or Level C without any supplementary test.

Any roof system, which satisfies requirements related to Level B, is deemed to satisfy the same requirements at Level C without any supplementary test.

SLS CERTIFICATION MARK

The Sri Lanka Standards Institution is the owner of the registered certification mark shown below. Beneath the mark, the number of the Sri Lanka Standard relevant to the product is indicated. This mark may be used only by those who have obtained permits under the SLS certification marks scheme. The presence of this mark on or in relation to a product conveys the assurance that they have been produced to comply with the requirements of the relevant Sri Lanka Standard under a well designed system of quality control inspection and testing operated by the manufacturer and supervised by the SLSI which includes surveillance inspection of the factory, testing of both factory and market samples.

Further particulars of the terms and conditions of the permit may be obtained from the Sri Lanka Standards Institution, 17, Victoria Place, Elvitigala Mawatha, Colombo 08.



SRI LANKA STANDARDS INSTITUTION

The Sri Lanka Standards Institution (SLSI) is the National Standards Organization of Sri Lanka established under the Sri Lanka Standards Institution Act No. 6 of 1984 which repealed and replaced the Bureau of Ceylon Standards Act No. 38 of 1964. The Institution functions under the Ministry of Science, Technology and Research.

The Principal objects of the Institution as set out in the Act are to prepare standards and promote their adoption, to provide facilities for examination and testing of products, to operate a Certification Marks Scheme, to certify the quality of products meant for local consumption or exports and to promote Standardization and quality control by educational, consultancy and research and research activity.

The Institution is financed by Government grants, and by the income from the sale of its publications and other services offered for Industry and Business Sector. Financial and Administrative control is vested in a Council appointed in accordance with the provisions of the Act.

The development and formulation of National Standards is carried out by Technical Experts and representatives of other interest groups, assisted by the permanent officers of the Institution. These Technical Committees are appointed under the purview of the Sectoral Committees which in return are appointed by the Council. The Sectoral Committees give the final Technical approval for the Draft National Standards prior to the approval by the Council of the SLSI.

All members of the Technical and Sectoral Committees render their services in an honorary capacity. In this process the Institution Endeavours to ensure adequate representation of all view points.

In the International field the Institution represents Sri Lanka in the International Organization for Standardization (ISO), and participates in such fields of Standardization as are of special interest to Sri Lanka.