

SRI LANKA STANDARD 1325 : 2007
ISO 3633 : 2002

**PLASTICS PIPING SYSTEMS FOR SOIL
AND WASTE DISCHARGE
(LOW AND HIGH TEMPERATURE) INSIDE
BUILDINGS – UNPLASTICIZED
POLY(VINYL CHLORIDE) (PVC-U)**

SRI LANKA STANDARDS INSTITUTION

- Blank Page -

SRI LANKA STANDARD
PLASTICS PIPING SYSTEMS FOR SOIL AND WASTE DISCHARGE
(LOW AND HIGH TEMPERATURE) INSIDE BUILDINGS –
UNPLASTICIZED POLY(VINYL CHLORIDE) (PVC-U)

SLS 1325 : 2007
ISO 3633 : 2002

Gr. N

SRI LANKA STANDARDS INSTITUTION
No. 17, Victoria Place
Elvitigala Mawatha
Colombo 08
SRI LANKA.

Sri Lanka Standards are subject to periodical revision in order to accommodate the progress made by industry. Suggestions for improvement will be recorded and brought to the notice of the Committees to which the revisions are entrusted.

This standard does not purport to include all the necessary provisions of a contract.

© SLSI 2007

All rights reserved. Unless otherwise specified, no part of this publication may be reproduced or utilized in any form or by any means, electronic or mechanical, including photocopying and microfilm, without permission in writing from the SLSI.

SRI LANKA STANDARD
PLASTICS PIPING SYSTEMS FOR SOIL AND WASTE DISCHARGE (LOW AND HIGH TEMPERATURE) INSIDE BUILDINGS – UNPLASTICIZED POLY (VINYL CHLORIDE) (PVC – U)

NATIONAL FOREWORD

This standard was approved by the Sectoral Committee on Materials, Mechanical Systems and Manufacturing Engineering and was authorized for adoption and publication as a Sri Lanka Standard by the council of the Sri Lanka Standards Institution on 2007-12-27.

This Sri Lanka Standard supercedes SLS 1202 and SLS 1210.

This is a direct adoption of ISO 3633 : 2002 - Plastics Piping Systems for Soil and Waste Discharge (Low and High Temperature) Inside Buildings – Unplasticized Poly (Vinyl Chloride) (PVC – U), together with a National Appendix indicating deviations from the International Standard and the additions.

TERMINOLOGY AND CONVENTIONS

The text of the International Standard has been accepted as suitable for publication, with some deviations as of The National Appendix as a Sri Lanka Standard. However certain terminology and conventions are not identical with those used in Sri Lanka Standards, attention is therefore drawn to the following:

- a) Wherever the words “International Standard” appear referring to this standard, they should be interpreted as “Sri Lanka Standard”.
- b) The comma has been used throughout as a decimal marker. In Sri Lanka Standards it is the current practice to use a full point on the.

Wherever page numbers are quoted, they are “ISO” page numbers, except for the National Appendix.

CROSS REFERANCES

There are no corresponding Sri Lanka Standards available for references in Clause 2.

NATIONAL APPENDIX

DEVIATIONS FROM ISO 3633 : 2002

Clause 6.5

Delete the 4th row of a) and substitute the following:

“ The nominal angle, α may be selected from the following:
15°, 22° 30', 30°, 45°, 67° 30', 80°, 87° 30' to 88° 30' ”.

Delete the 4th row of d) and substitute the following:

“ The nominal angle, α may be selected from the following:
45°, 67° 30', 80°, 87° 30' to 88° 30' ”.

Clause 8.1

Delete the Table 20 and substitute the following:

Table 20 – Physical characteristics of pipes

Characteristic	Requirements	Test parameters		Test method
Vicat softening temperature (VST)	≥ 79 °C	Shall conform to EN 727		EN 727
Longitudinal reversion ^a	$\leq 5\%$ The pipe shall exhibit no bubbles or cracks.	Temperature	150 °C	EN 743 Method A: Liquid
		Immersion time	15 min	
Resistance to acetone at room temperature	No delamination or disintegration.	Temperature	150 °C	EN 743 Method B: Air
		Immersion time	30 min	
Resistance to acetone at room temperature	No delamination or disintegration.	Temperature	Room temp	SLS 147
		immersion time	120 min	
^a The choice of method A or method B is in the responsibility of the manufacturer				

Clause 8.2

Delete the Table 21 and substitute the following:

Table 21 – Physical characteristics of fittings

Characteristic	Requirements	Test parameters		Test method
Vicat softening temperature (VST)	≥ 76 °C	Shall conform to EN 727		EN 727
Effects of heating	a and b given below.	Temperature Heating time	150 °C 30 min	EN 763 Method A: Air Oven
<p>a</p> <ol style="list-style-type: none"> 1) Within a radius of 15 times the wall thickness around the injection point, the depth of any cracks, delamination or blisters shall not exceed 50 % of the wall thickness at that point. 2) Within a distance of 10 times the wall thickness from the diaphragm zone, the depth of any cracks, delamination or blisters shall not exceed 50 % of the wall thickness in that zone. 3) Within a distance of 10 times the wall thickness from the ring gate, the length of any cracks shall not exceed 50 % of the wall thickness at that point. 4) The weld line shall not have opened by more than 50 % of the wall thickness at the time. 5) In all other parts of the surface, the depth of any cracks or delamination shall not exceed 30 % of the wall thickness at that point. Blisters shall not exceed a length 10 times the wall thickness. <p>b After cutting through the fitting, the cut surfaces, when viewed without magnification, shall show no foreign particles.</p>				

Clause 12.2 and Clause 12.3

Delete 1st row of Table 23 and 7th row of Table 24.

ADDITIONS

Add the following appendices as Appendix **A** and Appendix **B**.

APPENDIX A COMPLIANCE OF A LOT(for PIPES)

The sampling scheme given in this Appendix should be applied where compliances of a lot to the requirements of this standard is to be assessed based on statistical sampling and inspection.

Where compliance with this standard is to be assured based on manufacturer's control systems coupled with type testing and check tests or any other procedure, appropriate schemes of sampling and inspection should be adopted.

A.1 SAMPLING

A.1.1 *Lot*

All PVC pipes in a single consignment of the same type and size manufactured under essentially similar conditions, shall constitute a lot.

A.1.2 Scale of sampling

A.1.2.1 Samples shall be tested from each lot separately for ascertaining conformity of the lot to the requirements of this standard.

A.1.2.2 The number of PVC pipes to be taken from the lot shall depend on the size of the lot and outside diameter of PVC pipes and shall be in accordance with Table **25**.

A.1.2.3 PVC pipes shall be selected at random. In order to ensure randomness of selection, random number tables as given in **SLS 428** shall be used.

A.1.3 *Number of tests*

A.1.3.1 Each pipe selected as in **A.1.2.2** shall be examined for the requirements given in **12.1** and **12.2**.

A.1.3.2 Each pipe selected as in **A.1.2.2** shall be examined for the requirements given in **5.1** and **6.2** of this specification.

TABLE - 25 Scale of sampling

Number of PVC pipes in the lot (1)	Out side diameter up to and including 110 mm		Out side diameter above 110 mm		Size of Sub sample (6)
	Sample size (2)	Acceptance number (3)	Sample size (4)	Acceptance number (5)	
Up to 1000	20	1	3	0	3
1001 – 3000	32	1	13	0	3
3001 – 10000	50	2	20	1	5
10001 and above	80	3	32	1	5

A.1.3.3 If the lot has been found satisfactory in respect of visual and dimensional requirements, a sub-sample of size as given in Column 6 of Table 25 shall be drawn at random from the sample obtained as in A.1.2.2 and shall be subjected to the requirements given in 7.1 and 8.1. The required test pieces for each requirement shall be cut (one piece from one PVC pipe) from the PVC pipes of the sub-sample.

A.1.4 *Conformity to standard*

A.1.4.1 The lot shall be declared as conforming to the requirements of this standard if the following conditions are satisfied.

A.1.4.1 a) Each pipe satisfies the requirements given in 12.1 and 12.2 when examined as given in A.1.3.1

A.1.4.1 b) The number of PVC pipes, not conforming to one or more requirements given in 5.1 and 6.2, when examined as in A.1.3.2 is less than or equal to the corresponding acceptance number given in Column 3 or Column 5 of the Table 25 as applicable.

A.1.4.1 c) Each test piece tested as in A.1.3.3 satisfies the relevant requirements.

APPENDIX B

COMPLIANCE OF A LOT(for FITTINGS)

The sampling scheme given in this Appendix should be applied where compliances of a lot to the requirements of this standard is to be assessed based on statistical sampling and inspection.

Where compliance with this standard is to be assured based on manufacturer's control systems coupled with type testing and check tests or any other procedure, appropriate schemes of sampling and inspection should be adopted.

B.1 SAMPLING

B.1.1 *Lot*

All PVC fittings in a single consignment of the same type and size manufactured under essentially similar conditions, shall constitute a lot.

B.1.2 *Scale of sampling*

B.1.2.1 Samples shall be tested from each lot separately for ascertaining conformity of the lot to the requirements of this standard.

B.1.2.2 The number of PVC fittings to be taken from the lot shall be in accordance with Table 26.

TABLE 26 - Scale of sampling

Number of PVC fittings in the lot	Number of PVC fittings to be selected
Up to 280	13
281 to 500	14
500 to 1200	20
1201 and above	32

B.1.2.3 PVC fittings shall be selected at random. In order to ensure randomness of selection, random number tables as given in **SLS 428** shall be used.

B.1.3 *Number of tests*

B.1.3.1 Each fitting selected as in **B.1.2.2** shall be examined for the requirements given in **12.1** and **12.3** of this specification.

B.1.3.2 Each fitting inspected as in **B.1.3.1** shall be examined for the requirements given in **5.1** and **6.3** of this specification.

B.1.3.3 A sub sample of 3 fittings taken from the samples tested as in **B.1.3.2** shall be tested for the requirements given in Table **27**.

TABLE 27 - Number of samples to be tested for each requirement

Number of fittings	Requirement
1	1 st row of Table 21
2	2 nd row of Table 21

B.1.4 *Conformity to standard*

The lot shall be declared as conforming to the requirements of this standard if the following conditions are satisfied:

B.1.4.1 Each fitting inspected/tested as in **B.1.3.1** and **B.1.3.2** satisfies relevant requirements.

B.1.4.2 Each fitting tested as in **B.1.3.3** satisfies the relevant requirements.

INTERNATIONAL STANDARD

ISO 3633

Second edition
2002-09-01

Plastics piping systems for soil and waste discharge (low and high temperature) inside buildings — Unplasticized poly(vinyl chloride) (PVC-U)

*Systèmes de canalisations en plastique pour l'évacuation des eaux-vannes
et des eaux usées (à basse et à haute température) à l'intérieur des
bâtiments — Poly(chlorure de vinyle) non plastifié (PVC-U)*



Reference number
ISO 3633:2002(E)

© ISO 2002

PDF disclaimer

This PDF file may contain embedded typefaces. In accordance with Adobe's licensing policy, this file may be printed or viewed but shall not be edited unless the typefaces which are embedded are licensed to and installed on the computer performing the editing. In downloading this file, parties accept therein the responsibility of not infringing Adobe's licensing policy. The ISO Central Secretariat accepts no liability in this area.

Adobe is a trademark of Adobe Systems Incorporated.

Details of the software products used to create this PDF file can be found in the General Info relative to the file; the PDF-creation parameters were optimized for printing. Every care has been taken to ensure that the file is suitable for use by ISO member bodies. In the unlikely event that a problem relating to it is found, please inform the Central Secretariat at the address given below.

© ISO 2002

All rights reserved. Unless otherwise specified, no part of this publication may be reproduced or utilized in any form or by any means, electronic or mechanical, including photocopying and microfilm, without permission in writing from either ISO at the address below or ISO's member body in the country of the requester.

ISO copyright office
Case postale 56 • CH-1211 Geneva 20
Tel. + 41 22 749 01 11
Fax + 41 22 749 09 47
E-mail copyright@iso.ch
Web www.iso.ch

Printed in Switzerland

Contents

Page

Foreword	iv
Introduction.....	v
1 Scope.....	1
2 Normative references.....	1
3 Symbols and abbreviations.....	2
3.1 Symbols.....	2
3.2 Abbreviations	3
4 Material.....	3
4.1 Raw material	3
4.2 Sealing ring retaining means	3
4.3 Fire behaviour.....	3
5 General characteristics.....	4
5.1 Appearance	4
5.2 Colour.....	4
6 Geometrical characteristics	4
6.1 General	4
6.2 Dimensions of pipes	4
6.3 Dimensions of fittings.....	8
6.4 Diameters and lengths of sockets and spigots	13
6.5 Types of fitting.....	20
7 Mechanical characteristics of pipes.....	23
7.1 General characteristics.....	23
7.2 Additional characteristics	25
8 Physical characteristics	26
8.1 Physical characteristics of pipes	26
8.2 Physical characteristics of fittings.....	26
9 Performance requirements.....	27
10 Sealing rings	27
11 Adhesives	27
12 Marking.....	27
12.1 General	27
12.2 Minimum required marking of pipes	28
12.3 Minimum required marking of fittings.....	28
13 Installation of piping systems.....	29
Bibliography.....	30

Foreword

ISO (the International Organization for Standardization) is a worldwide federation of national standards bodies (ISO member bodies). The work of preparing International Standards is normally carried out through ISO technical committees. Each member body interested in a subject for which a technical committee has been established has the right to be represented on that committee. International organizations, governmental and non-governmental, in liaison with ISO, also take part in the work. ISO collaborates closely with the International Electrotechnical Commission (IEC) on all matters of electrotechnical standardization.

International Standards are drafted in accordance with the rules given in the ISO/IEC Directives, Part 3.

The main task of technical committees is to prepare International Standards. Draft International Standards adopted by the technical committees are circulated to the member bodies for voting. Publication as an International Standard requires approval by at least 75 % of the member bodies casting a vote.

Attention is drawn to the possibility that some of the elements of this International Standard may be the subject of patent rights. ISO shall not be held responsible for identifying any or all such patent rights.

ISO 3633 was prepared by Technical Committee ISO/TC 138, *Plastics pipes, fittings and valves for the transport of fluids*, Subcommittee SC 1, *Plastics pipes and fittings for soil, waste and drainage (including land drainage)*.

This second edition cancels and replaces the first edition (ISO 3633:1991), which has been technically revised.

Introduction

Pipes and fittings conforming to this International Standard also meet the requirements of EN 1329-1 which are applicable to those pipes and fittings which, according to EN 1329-1, are intended to be used inside buildings (application area code "B", see EN 1329-1) only.

Plastics piping systems for soil and waste discharge (low and high temperature) inside buildings — Unplasticized poly(vinyl chloride) (PVC-U)

1 Scope

This International Standard specifies the requirements for unplasticized poly(vinyl chloride) (PVC-U) pipes and fittings for soil and waste discharge (low and high temperature) inside buildings, as well as the system itself. It does not include buried pipework.

It also specifies the test parameters for the test methods referred to in this International Standard.

This International Standard is applicable to PVC-U pipes and fittings, as well as assemblies of such pipes and fittings, intended to be used for the following purposes:

- a) soil and waste discharge pipework for the conveyance of domestic waste waters (low and high temperature);
- b) ventilation pipework associated with a);
- c) rainwater pipework inside the building.

This International Standard does not cover requirements for the K -value of the raw material.

2 Normative references

The following normative documents contain provisions which, through reference in this text, constitute provisions of this International Standard. For dated references, subsequent amendments to, or revisions of, any of these publications do not apply. However, parties to agreements based on this International Standard are encouraged to investigate the possibility of applying the most recent editions of the normative documents indicated below. For undated references, the latest edition of the normative document referred to applies. Members of ISO and IEC maintain registers of currently valid International Standards.

ISO 265-1, *Pipes and fittings of plastics materials — Fittings for domestic and industrial waste pipes — Basic dimensions: Metric series — Part 1: Unplasticized poly(vinyl chloride) (PVC-U)*

ISO 3126:—¹⁾, *Plastics piping systems — Plastics piping components — Measurement and determination of dimensions*

EN 580, *Plastics piping systems — Unplasticized poly(vinyl chloride) (PVC-U) pipes — Test method for the resistance to dichloromethane at a specified temperature (DCMT)*

EN 681-1, *Elastomeric seals — Materials requirements for pipe joint seals used in water and drainage applications — Part 1: Vulcanized rubber*

1) To be published. (Revision of ISO 3126:1974)

EN 681-2, *Elastomeric seals — Materials requirements for pipe joint seals used in water and drainage applications — Part 2: Thermoplastic elastomers*

EN 727, *Plastics piping and ducting systems — Thermoplastics pipes and fittings — Determination of Vicat softening temperature (VST)*

EN 743, *Plastics piping and ducting systems — Thermoplastics pipes — Determination of the longitudinal reversion*

EN 744, *Plastics piping and ducting systems — Thermoplastics pipes — Test method for resistance to external blows by the round-the-clock method*

EN 763, *Plastics piping and ducting systems — Injection-moulded thermoplastics fittings — Test method for visually assessing effects of heating*

EN 1053, *Plastics piping systems — Thermoplastics piping systems for non-pressure applications — Test method for watertightness*

EN 1054, *Plastics piping systems — Thermoplastics piping systems for soil and waste discharge — Test method for airtightness of joints*

EN 1055:1996, *Plastics piping systems — Thermoplastics piping systems for soil and waste discharge inside buildings — Test method for resistance to elevated temperature cycling*

EN 1329-1, *Plastics piping systems for soil and waste discharge (low and high temperature) within the building structure — Unplasticized poly(vinyl chloride) (PVC-U) — Part 1: Specifications for pipes, fittings and the system*

EN 1411, *Plastics piping and ducting systems — Thermoplastics pipes — Determination of resistance to external blows by the staircase method*

EN 1905, *Plastics piping systems — Unplasticized poly(vinyl chloride) (PVC-U) pipes, fittings and material — Method for assessment of the PVC content based on total chlorine content*

3 Symbols and abbreviations

3.1 Symbols

A	length of engagement
C	depth of sealing zone
d_e	outside diameter (at any point)
d_{em}	mean outside diameter
d_n	nominal outside diameter
d_s	inside diameter of the socket
d_{sm}	mean inside diameter of the socket
DN	nominal size
DN/OD	nominal size (outside-diameter related)
e	wall thickness (at any point)
e_m	mean wall thickness

e_2	wall thickness of the socket
e_3	wall thickness at the groove
H	length of chamfer
L_1	length of spigot
L_2	length of socket
l	effective length of a pipe
R	radius of swept fittings
z	design length (z -length) of a fitting
α	nominal angle of a fitting

3.2 Abbreviations

PVC-U	unplasticized poly(vinyl chloride)
TIR	true impact rate

4 Material

4.1 Raw material

The raw material shall be PVC-U to which are added those additives that are needed to facilitate the manufacture of components conforming to the requirements of this International Standard. For the use of non-virgin material, it is recommended that the specifications given in EN 1329-1 are followed.

NOTE Definitions concerning materials are given in EN 1329-1.

When calculated for a known formulation, and in cases of dispute and in cases when the formulation is not known, the PVC content, determined in accordance with EN 1905, shall be at least 80 % by mass for pipes and at least 85 % by mass for injection-moulded fittings.

4.2 Sealing ring retaining means

Sealing rings may be retained using means made from polymers other than PVC-U, provided the joints conform to the requirements given in clause 9.

4.3 Fire behaviour

No specific requirements are set by this International Standard for fire behaviour. Attention is drawn to the need to comply with any relevant national regulations in this respect.

5 General characteristics

5.1 Appearance

When viewed without magnification, the following requirements shall be met:

- the internal and external surfaces of pipes and fittings shall be smooth, clean and free from grooving, blistering, impurities, pores or any other surface irregularity likely to prevent conformity of pipes and fittings to this International Standard;
- each end of a pipe or fitting shall be cleanly cut, if applicable, and shall be square to its axis.

5.2 Colour

Pipes and fittings shall be coloured through the whole wall.

The recommended colour for pipes and fittings is grey.

6 Geometrical characteristics

6.1 General

All dimensions shall be measured in accordance with ISO 3126:—.

In cases of dispute, the reference temperature shall be (23 ± 2) °C.

The figures are schematic sketches only, to indicate the relevant dimensions. They do not necessarily represent manufactured components. The dimensions given shall be conformed to however.

6.2 Dimensions of pipes

6.2.1 Outside diameter

The mean outside diameter, d_{em} , shall conform to Table 1 or Table 2, as applicable.

6.2.2 Out-of-roundness

The out-of-roundness, measured directly after production, shall be less than or equal to $0,024d_n$.

Table 1 — Mean outside diameters
 (metric series)

Dimensions in millimetres

Nominal size DN/OD	Nominal outside diameter d_n	Mean outside diameter	
		min.	max.
32	32	32,0	32,2
40	40	40,0	40,2
50	50	50,0	50,2
63	63	63,0	63,2
75	75	75,0	75,3
80	80	80,0	80,3
82	82	82,0	82,3
90	90	90,0	90,3
100	100	100,0	100,3
110	110	110,0	110,3
125	125	125,0	125,3
140	140	140,0	140,4
160	160	160,0	160,4
180	180	180,0	180,4
200	200	200,0	200,5
250	250	250,0	250,5
315	315	315,0	315,6

Table 2 — Mean outside diameters
 (series based on inch dimensions)

Dimensions in millimetres

Nominal size DN/OD	Nominal outside diameter d_n	Mean outside diameter	
		min.	max.
36	36	36,2	36,5
43	43	42,8	43,1
56	56	55,8	56,1

6.2.3 Effective lengths of pipes

The effective length (useful length) of a pipe, l , shall be not less than that specified by the manufacturer when measured as shown in Figure 1.

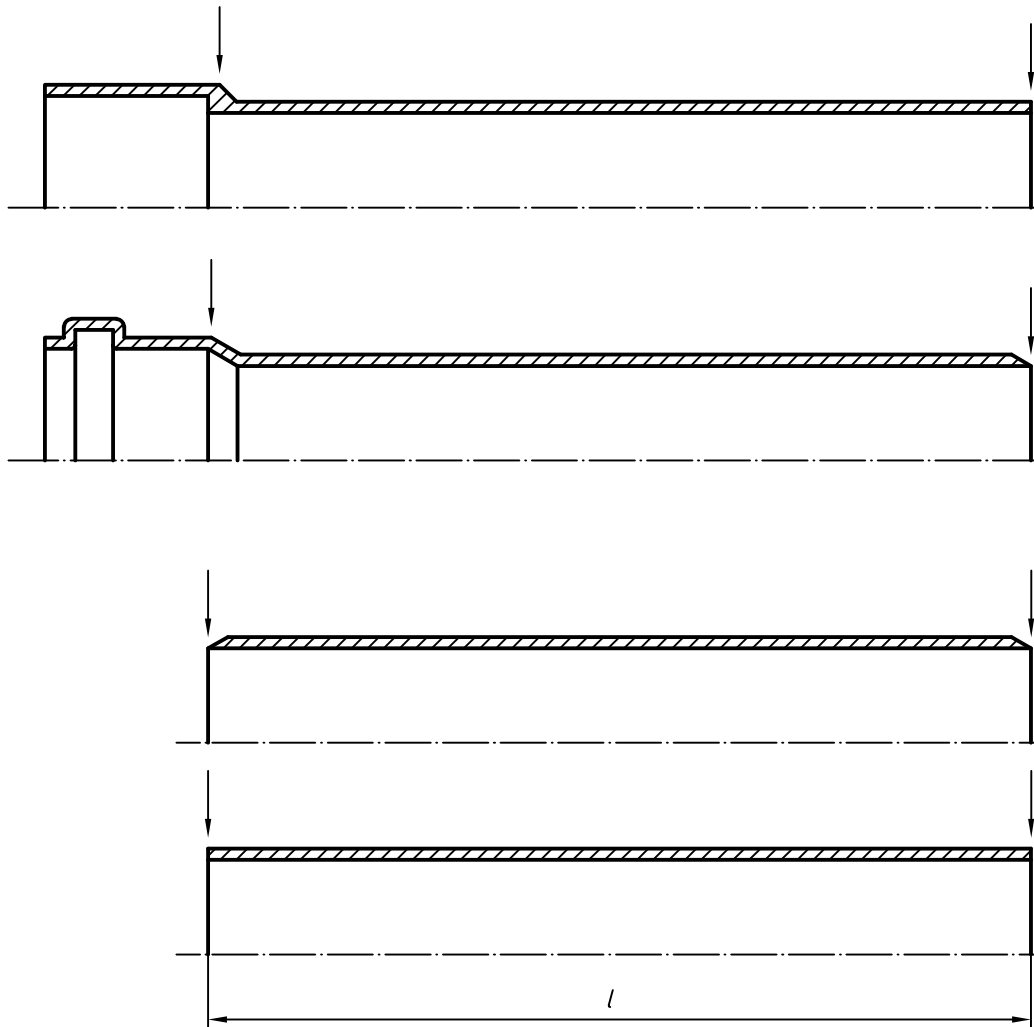

Figure 1 — Effective lengths of pipes

6.2.4 Chamfering

If a chamfer is applied, the angle of chamfering shall be between 15° and 45° to the axis of the pipe (see Figure 4 or 5). The remaining wall thickness at the end of the pipe shall be at least $1/3$ of e_{\min} .

6.2.5 Wall thickness

The wall thickness, e , shall conform to Table 3 or Table 4, as applicable, but for the metric series a maximum wall thickness at any point up to $1,2e_{\min}$ is permitted, provided that the mean wall thickness, e_m , is less than or equal to the specified $e_{m,\max}$.

Table 3 — Wall thicknesses
 (metric series)

Dimensions in millimetres

Nominal size DN/OD	Nominal outside diameter d_n	Wall thickness	
		e min.	e_m max.
32	32	3	3,5
40	40	3	3,5
50	50	3	3,5
63	63	3	3,5
75	75	3	3,5
80	80	3	3,5
82	82	3	3,5
90	90	3	3,5
100	100	3	3,5
110	110	3,2	3,8
125	125	3,2	3,8
140	140	3,2	3,8
160	160	3,2	3,8
180	180	3,6	4,2
200	200	3,9	4,5
250	250	4,9	5,6
315	315	6,2	7,1

Table 4 — Wall thicknesses
 (series based on inch dimensions)

Dimensions in millimetres

Nominal size DN/OD	Nominal outside diameter d_n	Wall thickness	
		e min.	e_m max.
36	36	3	3,5
43	43	3	3,5
56	56	3	3,5

6.2.6 Dimensions of sockets

The dimensions of solvent cement sockets (see Figure 4) and ring seal sockets (see Figure 5) of pipes shall be the same as for fittings (see 6.4).

6.3 Dimensions of fittings

6.3.1 Outside diameters

The mean outside diameter, d_{em} , of the spigot shall conform to Table 1 or Table 2, as applicable.

6.3.2 z-lengths

The design length(s) [z-length(s)] of fittings (see Figures 8 to 11 and 13 to 17) shall be given by the manufacturer.

NOTE The z-length(s) of a fitting are intended to assist in the design of moulds and are not intended to be used for quality control purposes. ISO 265-1 may be used as a guideline.

6.3.3 Wall thickness

6.3.3.1 General

Fittings and those parts of fittings not intended to come into contact with the fluid being conveyed are not required to conform to the wall thicknesses given in Tables 5 to 7, as applicable.

Where a fitting or adaptor provides a transition between two nominal sizes, the wall thickness of each connecting part shall conform to the requirements for the applicable nominal size. In such cases, the wall thickness of the fitting body is permitted to change gradually from the one wall thickness to the other.

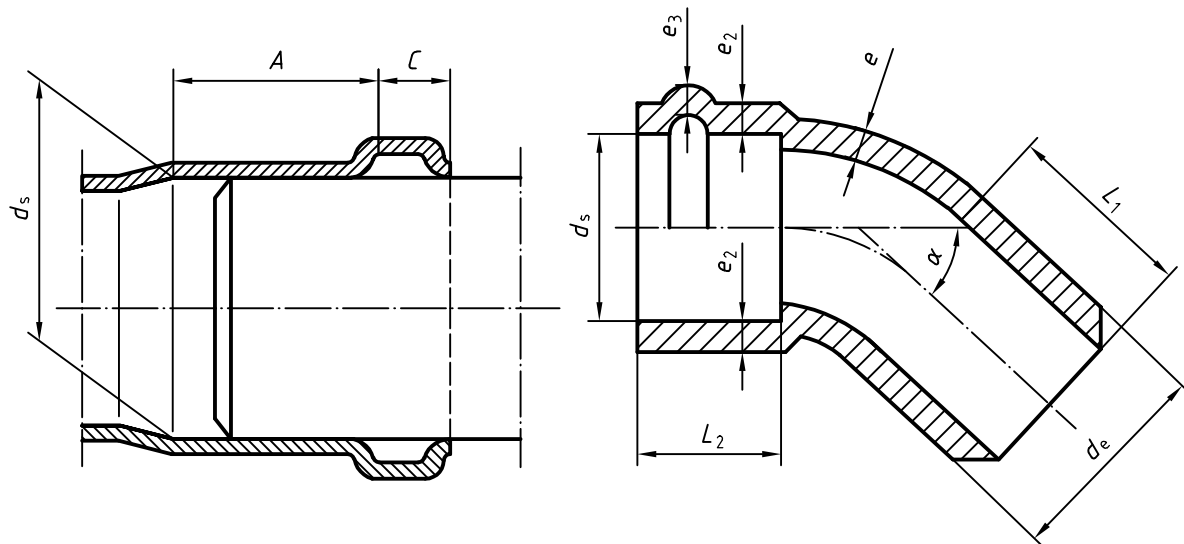

Figure 2 — Points of measurement for spigots and typical type of socket

6.3.3.2 Solvent cement fittings

For solvent cement fittings, the wall thicknesses, e and e_2 (see Figure 2), shall be equal to or greater than the values given in Table 5 or Table 6, as applicable.

For solvent cement fittings, a reduction of 5 % in wall thickness resulting from core shifting is permitted. In such a case, the average of two opposite wall thicknesses shall be equal to or greater than the values given in Table 5 or Table 6, as applicable.

Table 5 — Wall thicknesses of solvent cement fittings
 (metric series)

Dimensions in millimetres			
Nominal size	Nominal outside diameter	Wall thickness	Wall thicknesses of sockets and spigots ^a
DN/OD	d_n	e min.	e_2 min. ($e_2 = 0,75e$)
32	32	3	2 ^b
40	40	3	2 ^b
50	50	3	2 ^b
63	63	3	2 ^b
75	75	3	2 ^b
80	80	3	2,3
82	82	3	2,3
90	90	3	2,3
100	100	3	2,3
110	110	3,2	2,4
125	125	3,2	2,4
140	140	3,2	2,4
160	160	3,2	2,4
180	180	3,6	2,7
200	200	3,9	2,9
250	250	4,9	3,7
315	315	6,2	4,7

^a Where the wall thickness of spigots is below e_{min} , these fittings may only be used in a solvent cement system and shall be marked in accordance with Table 24 as being for solvent cement joints only.

^b $e_2 = 0,65e$. Fittings with such a wall thickness may only be used in a solvent cement system and shall be marked in accordance with Table 24 as being for solvent cement joints only.

Table 6 — Wall thicknesses of solvent cement fittings
 (series based on inch dimensions)

Dimensions in millimetres

Nominal size	Nominal outside diameter	Wall thickness	Wall thicknesses of sockets and spigots ^a
DN/OD	d_n	e min.	e_2 min. ($e_2 = 0,75e$)
36	36	3	2,3
43	43	3	2,3
56	56	3	2,3
For existing tools, the following values of the wall thickness are allowed, provided that the deviating value of the wall thickness, e , is marked on the fitting:			
DN/OD	d_n	e min.	e_2 min.
36	36	2,7	2
43	43	2,7	2
56	56	2,7	2
^a Where the wall thicknesses of spigots are below e_{min} , these fittings may only be used in a solvent cement system and shall be marked in accordance with Table 24 as being for solvent cement joints only.			

6.3.3.3 Ring seal fittings

For ring seal fittings, the wall thicknesses e , e_2 and e_3 (see Figure 2), shall be equal to or greater than the values given in Table 7 or Table 8, as applicable.

For ring seal fittings, a reduction of 5 % in the wall thickness resulting from core shifting is permitted. In such a case, the average of two opposite wall thicknesses shall be equal to or greater than the values given in Table 7 or Table 8, as applicable.

Where a sealing ring is located by means of a retaining cap or ring (see Figure 3), the wall thickness in this area shall be calculated by addition of the wall thickness of the socket and the wall thickness of the retaining cap or ring at the corresponding places in the same cross-sectional plane.

Table 7 — Wall thicknesses of ring seal fittings including expansion couplings
 (metric series)

Dimensions in millimetres

Nominal size	Nominal outside diameter	Wall thickness	Wall thicknesses of sockets ($e_2 = 0,9e$)	Wall thickness at groove ($e_3 = 0,75e$)
DN/OD	d_n	e min.	e_2 min.	e_3 min.
32	32	3	2,7	2,3
40	40	3	2,7	2,3
50	50	3	2,7	2,3
63	63	3	2,7	2,3
75	75	3	2,7	2,3
80	80	3	2,7	2,3
82	82	3	2,7	2,3
90	90	3	2,7	2,3
100	100	3	2,7	2,3
110	110	3,2	2,9	2,4
125	125	3,2	2,9	2,4
140	140	3,2	2,9	2,4
160	160	3,2	2,9	2,4
180	180	3,6	3,2	2,7
200	200	3,9	3,5	2,9
250	250	4,9	4,5	3,7
315	315	6,2	5,6	4,7

Table 8 — Wall thicknesses of expansion couplings
 (series based on inch dimensions)

Dimensions in millimetres

Nominal size	Nominal outside diameter	Wall thickness	Wall thicknesses of sockets ($e_2 = 0,9e$)	Wall thickness at groove ($e_3 = 0,75e$)
DN/OD	d_n	e min.	e_2 min.	e_3 min.
36	36	3	2,7	2,2
43	43	3	2,7	2,2
56	56	3	2,7	2,2

For existing tools, the following values of the wall thickness are allowed, provided that the deviating value of the wall thickness, e , is marked on the fitting:

DN/OD	d_n	e min.	e_2 min.	e_3 min.
36	36	2,7	2,4	2
43	43	2,7	2,4	2
56	56	2,7	2,4	2

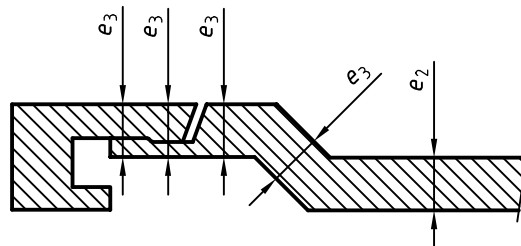

Figure 3 — Example of calculation of wall thickness of socket with retaining cap

6.4 Diameters and lengths of sockets and spigots

6.4.1 Solvent cement sockets and spigots

The diameters and lengths of solvent cement sockets and spigots (see Figure 4) shall conform to Table 9 or Table 10, as applicable.

The manufacturer shall state whether the components are designed with a tapered or a parallel socket. If the socket is tapered, the minimum and maximum values given for d_{sm} shall apply at the mid mean point of the socket with a maximum taper angle of $20'$ per side. Otherwise, these values of d_{sm} shall apply over the entire length of the socket.

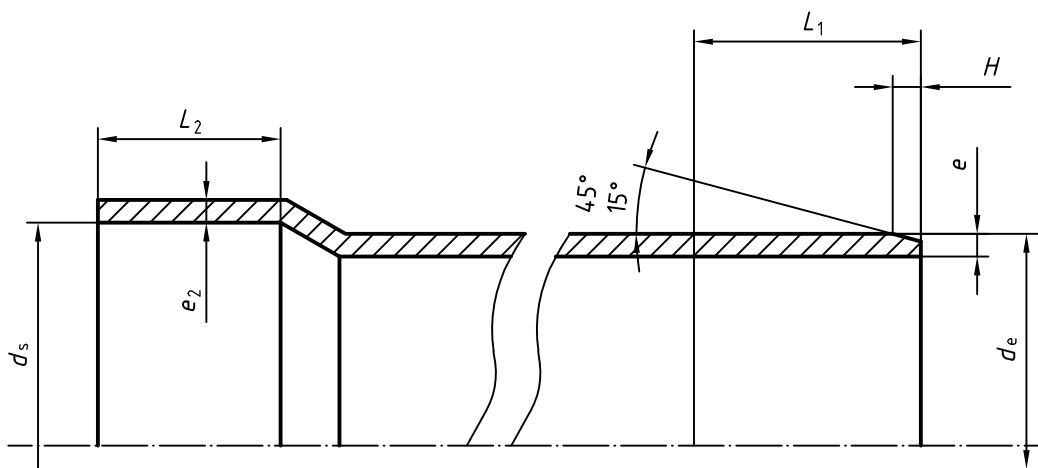

Figure 4 — Basic dimensions of sockets and spigots for solvent cement joints

Table 9 — Diameters and lengths of solvent cement sockets and spigots
 (metric series)

Dimensions in millimetres

Nominal size DN/OD	Nominal outside diameter d_n	Mean outside diameter of spigot		Mean inside diameter of socket		Lengths of sockets and spigots L_1 and L_2 ^a min.
		d_{em}		d_{sm}		
		min.	max.	min.	max.	
32	32	32,0	32,2	32,1	32,4	22
40	40	40,0	40,2	40,1	40,4	26
50	50	50,0	50,2	50,1	50,4	30
63	63	63,0	63,2	63,1	63,4	36
75	75	75,0	75,3	75,2	75,5	40
80	80	80,0	80,3	80,2	80,5	42
82	82	82,0	82,3	82,2	82,5	43
90	90	90,0	90,3	90,2	90,5	46
100	100	100,0	100,3	100,2	100,5	46
110	110	110,0	110,3	110,2	110,6	48
125	125	125,0	125,3	125,2	125,7	51
140	140	140,0	140,4	140,3	140,8	54
160	160	160,0	160,4	160,3	160,8	58
180	180	180,0	180,4	180,3	180,8	60
200	200	200,0	200,5	200,4	200,9	60
250	250	250,0	250,5	250,4	250,9	60
315	315	315,0	315,6	315,5	316,0	60

^a For joints intended for fabrication within a workshop, the values of L_2 may be reduced to C_{max} (see Table 12).

Table 10 — Diameters and lengths of solvent cement sockets and spigots
 (series based on inch dimensions)

Dimensions in millimetres

Nominal size DN/OD	Nominal outside diameter d_n	Mean outside diameter of spigot		Mean inside diameter of socket		Lengths of sockets and spigots L_1 and L_2 min.
		d_{em}		d_{sm}		
		min.	max.	min.	max.	
36	36	36,2	36,5	36,3	36,6	18
43	43	42,8	43,1	42,9	43,2	21
56	56	55,8	56,1	55,9	56,2	27

6.4.2 Ring seal sockets and spigots

The diameters and lengths of ring seal sockets and spigots (see Figure 5 and Figure 6) shall conform to one of the following tables, as applicable:

- Table 11 for type S I (short type, system I);
- Table 12 for type S II (short type, system II);
- Table 13 for type M (medium type).

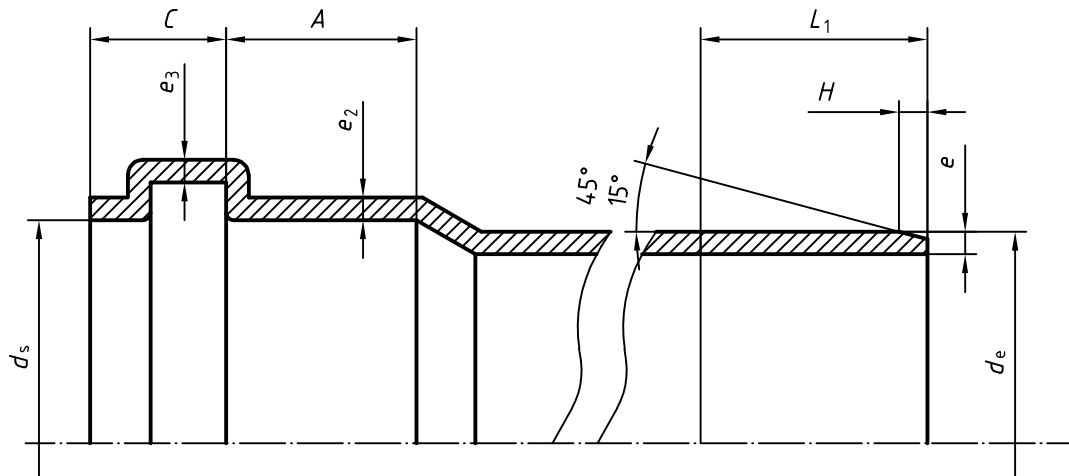

Figure 5 — Basic dimensions of sockets and spigots for elastomeric ring seal joints

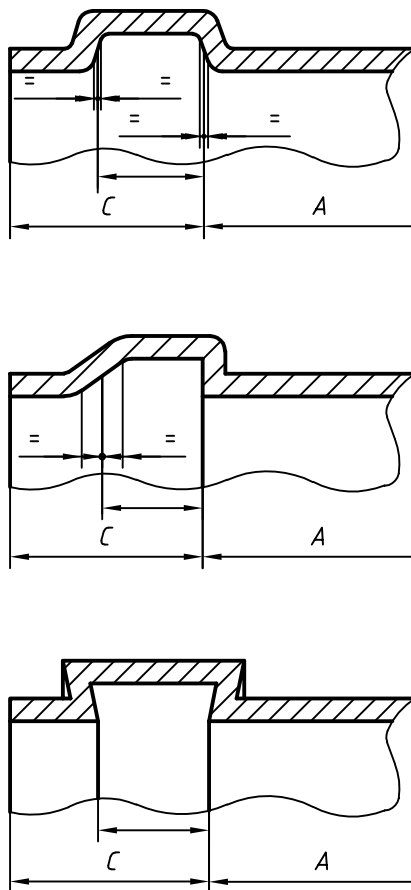

Figure 6 — Typical groove designs for elastomeric ring seal sockets

Where sealing rings are firmly retained, the minimum value for A and the maximum value for C shall be measured to the effective sealing point (see Figure 7) as specified by the manufacturer and, if applicable, in agreement with a certification body.

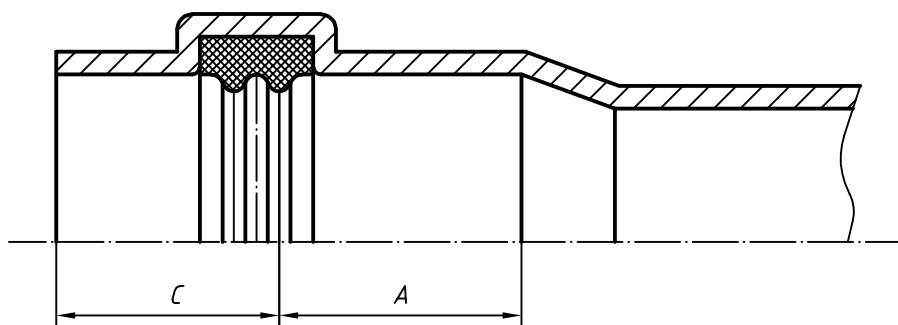

Figure 7 — Example of measurement of effective sealing point

Table 11 — Diameters and lengths of ring seal sockets and spigots, type S I (short type, system I)

Dimensions in millimetres

Nominal size DN/OD	Mean outside diameter of spigot		Mean inside diameter of socket	Lengths of sockets and spigots		
	d_{em}			A	C	L_1
	min.	max.				
32	32,0	32,2	32,3	16	18	34
40	40,0	40,2	40,3	18	18	36
50	50,0	50,2	50,3	20	18	37
63	63,0	63,2	63,3	22	20	37
75	75,0	75,3	75,4	25	20	43
80	80,0	80,3	80,4	26	21	44
82	82,0	82,3	82,4	26	21	44
90	90,0	90,3	90,4	28	22	46
100	100,0	100,3	100,4	30	22	46
110	110,0	110,3	110,4	32	26	54
125	125,0	125,3	125,4	35	26	60
140	140,0	140,4	140,5	38	26	60
160	160,0	160,4	160,5	42	32	60
180	180,0	180,4	180,5	46	36	60
200	200,0	200,5	200,6	50	40	60

Table 12 — Diameters and lengths of ring seal sockets and spigots, type S II (short type, system II)

Dimensions in millimetres

Nominal size DN/OD	Mean outside diameter of spigot		Mean inside diameter of socket	Lengths of sockets and spigots		
	d_{em}			A	C	L_1
	min.	max.				
32	32,0	32,2	32,3	16	18	42
40	40,0	40,2	40,3	18	18	44
50	50,0	50,2	50,3	20	18	46
63	63,0	63,2	63,3	22	20	49
75	75,0	75,3	75,4	25	20	51
80	80,0	80,3	80,4	26	21	52
82	82,0	82,3	82,4	26	21	52
90	90,0	90,3	90,4	28	22	56
100	100,0	100,3	100,4	30	22	56
110	110,0	110,3	110,4	32	26	60
125	125,0	125,3	125,4	35	26	67
140	140,0	140,4	140,5	38	26	70
160	160,0	160,4	160,5	42	32	81
180	180,0	180,4	180,5	46	36	90
200	200,0	200,5	200,6	50	40	99
250	250,0	250,5	250,8	55	70	125
315	315,0	315,6	316,0	62	70	132

Table 13 — Diameters and lengths of ring seal sockets and spigots, type M (medium type)

Dimensions in millimetres

Nominal size DN/OD	Mean outside diameter of spigot		Mean inside diameter of socket	Lengths of sockets and spigots		
	d_{em}			A	C	L_1
	min.	max.				
32	32,0	32,2	32,3	24	18	42
40	40,0	40,2	40,3	26	18	44
50	50,0	50,2	50,3	28	18	46
63	63,0	63,2	63,3	31	20	49
75	75,0	75,3	75,4	33	20	51
80	80,0	80,3	80,4	34	21	52
82	82,0	82,3	82,4	34	21	52
90	90,0	90,3	90,4	36	22	56
100	100,0	100,3	100,4	38	22	56
110	110,0	110,3	110,4	40	26	60
125	125,0	125,3	125,4	43	26	67
140	140,0	140,4	140,5	46	26	70
160	160,0	160,4	160,5	50	32	81
180	180,0	180,4	180,5	54	36	90
200	200,0	200,5	200,6	58	40	99

6.4.3 One-piece expansion couplings for solvent cement sockets and spigots

The diameters and lengths of one-piece expansion couplings shall conform to Table 14 for type M (medium type) or Table 15 for type L (long type), as applicable.

Table 14 — Diameters and lengths of one-piece expansion couplings, type M (medium type), for solvent cement sockets and spigots
(series based on inch dimensions)

Dimensions in millimetres

Nominal size DN/OD	Mean outside diameter of spigot		Mean inside diameter of socket	Lengths of sockets and spigots	
	d_{em}			A	L_1
	min.	max.			
36	36,2	36,5	36,6	25	37
43	42,8	43,1	43,2	25	40
56	55,8	56,1	56,2	25	43

**Table 15 — Diameters and lengths of one-piece expansion couplings, type L (long type),
 for solvent cement sockets and spigots
 (metric series)**

Dimensions in millimetres

Nominal size DN/OD	Mean outside diameter of spigot		Mean inside diameter of socket	Lengths of sockets and spigots	
	d_{em}			A	L_1
	min.	max.			
32	32,0	32,2	32,3	65	22
40	40,0	40,2	40,3	65	26
50	50,0	50,2	50,3	65	31
63	63,0	63,2	63,3	65	37
75	75,0	75,3	75,4	65	43
80	80,0	80,3	80,4	65	44
82	82,0	82,3	82,4	65	46
90	90,0	90,3	90,4	65	46
100	100,0	100,3	100,4	65	54
110	110,0	110,3	110,4	65	60
125	125,0	125,3	125,4	65	60
140	140,0	140,4	140,5	65	60
160	160,0	160,4	160,5	65	60
180	180,0	180,4	180,5	65	60
200	200,0	200,5	200,6	65	60

6.5 Types of fitting

This International Standard is applicable to the following generic types of fitting. Other designs of fitting are permitted.

a) Bends (see Figure 8, 9, 10 or 11):

- unswept or swept angle (see ISO 265-1);
- spigot/socket or socket/socket.

The nominal angle, α , may be selected from the following: 15°, 22°30', 30°, 45°, 67°30', 80°, 87°30' to 90°.

b) Couplers (see Figure 12).

c) Reducers (see Figure 13).

d) Branches and reducing branches (branching single or multiple) (see Figure 14, 15, 16 or 17):

- unswept or swept angle (see ISO 265-1);
- spigot/socket or socket/socket.

The nominal angle, α , may be selected from the following: 45°, 67°30', 80°, 87°30' to 90°.

If other angles are required, they shall be agreed between the manufacturer and purchaser and be identified accordingly.

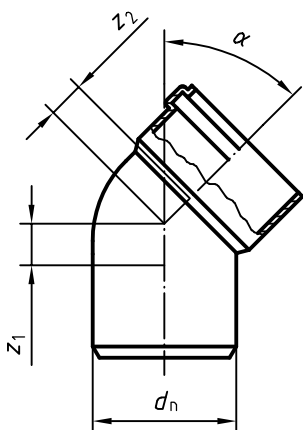

Figure 8 — Bend with single socket (unswept)

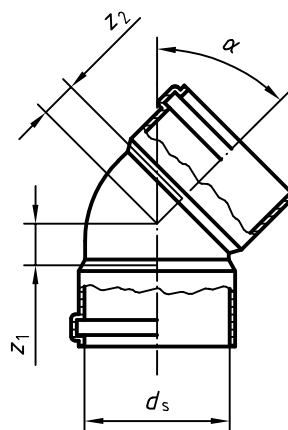

Figure 9 — Bend with only sockets (unswept)

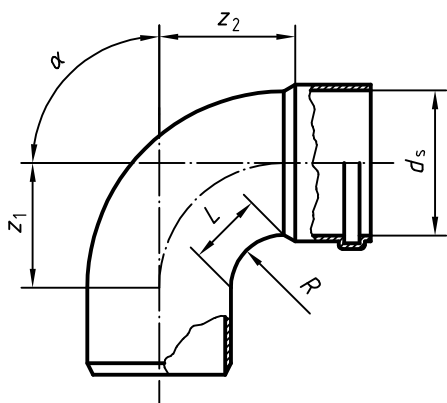

Figure 10 — Bend with single socket (swept)

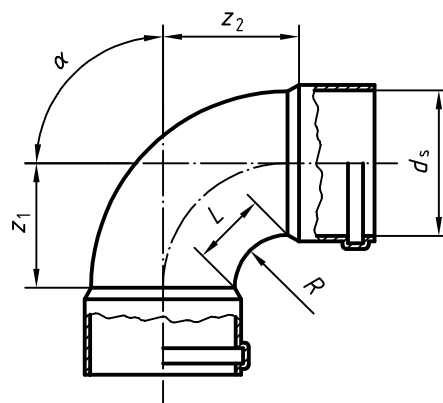

Figure 11 — Bend with only sockets (swept)

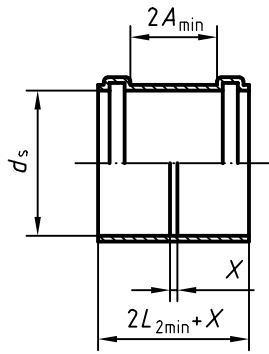

Figure 12 — Coupler

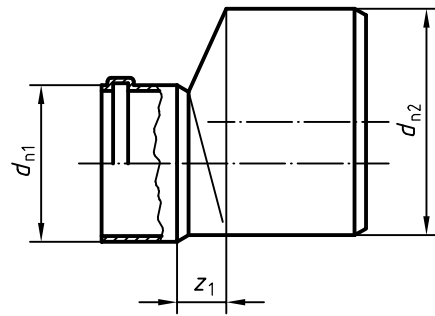

Figure 13 — Reducer

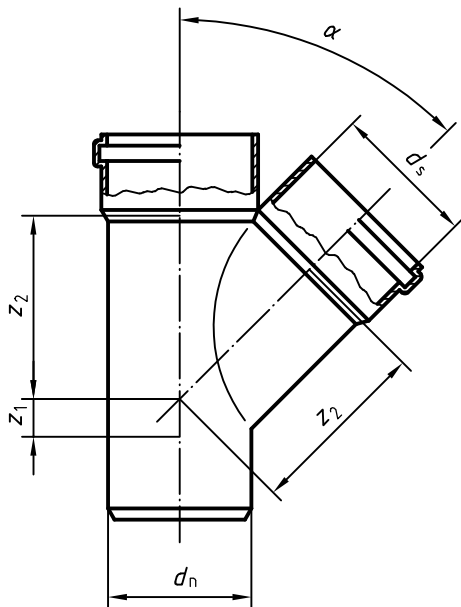

Figure 14 — Branch with single socket (unswept)

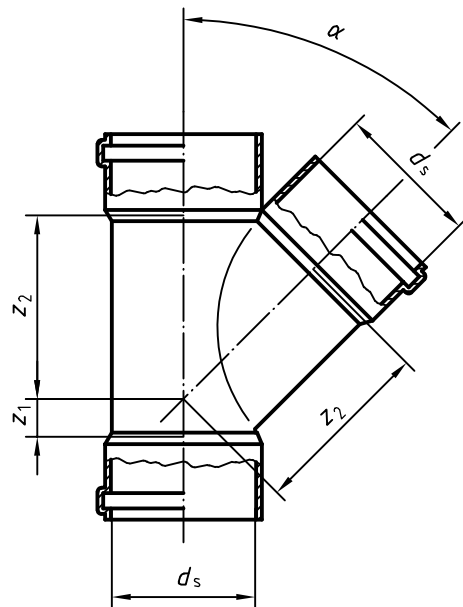

Figure 15 — Branch with only sockets (unswept)

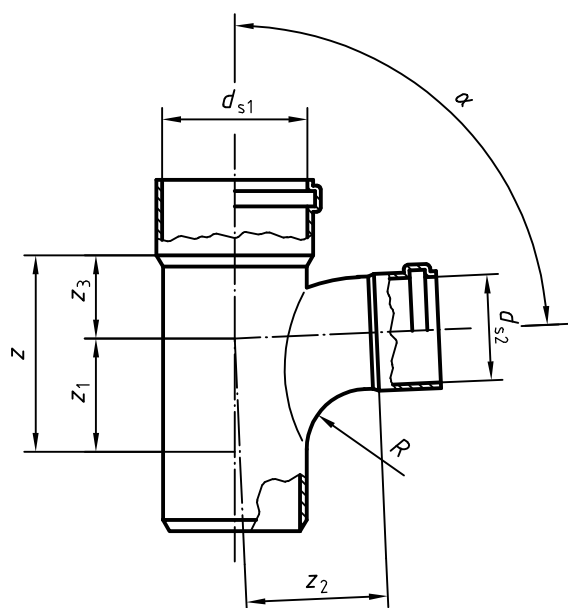

Figure 16 — Reducing branch with single socket (swept)

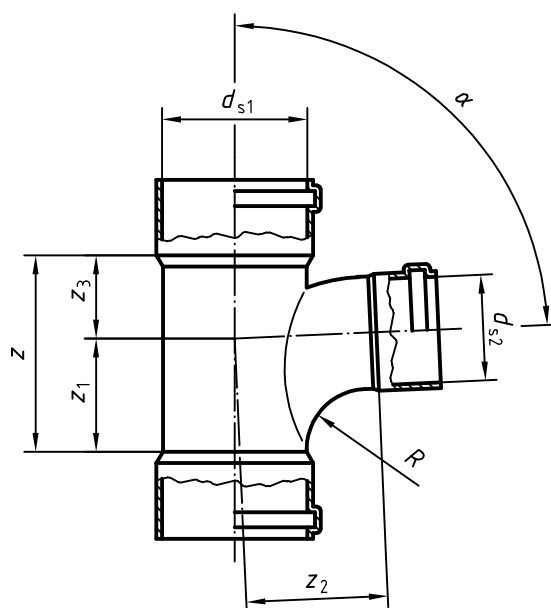

Figure 17 — Reducing branch with only sockets (swept)

7 Mechanical characteristics of pipes

7.1 General characteristics

When determined in accordance with the method specified in Table 16, using the parameters indicated, the general mechanical characteristics of pipes shall conform to the requirements given in Table 16.

The mass and drop height of the striker used in determining the impact resistance (round-the-clock method) as specified in Table 16 are given in Table 17 or Table 18, as applicable.

Table 16 — General mechanical characteristics of pipes

Characteristic	Requirements	Test parameters		Test method
Impact resistance (round-the-clock method)	TIR \leq 10 %	Type of striker for $d_n < 110$ mm $d_n \geq 110$ mm	Type d25 Type d90	EN 744
		Mass of striker	See Table 17 or Table 18, as applicable	
		Drop height of striker	See Table 17 or Table 18, as applicable	
		Conditioning medium	Water	
		Conditioning and test temperature	(0 \pm 1) °C	
NOTE In the event of indirect testing, the preferred temperature is (23 \pm 2) °C.				

Table 17 — Drop height and mass of striker for impact resistance
 (metric series)

Dimensions in millimetres

Nominal size DN/OD	Nominal outside diameter d_n	Mass of striker kg	Drop height of striker
32	32	0,5	600
40	40	0,5	800
50	50	0,5	1 000
63	63	0,8	1 000
75	75	0,8	1 000
80	80	0,8	1 000
82	82	0,8	1 000
90	90	0,8	1 200
100	100	0,8	1 200
110	110	1	1 600
125	125	1,25	2 000
140	140	1,6	1 800
160	160	1,6	2 000
180	180	2	1 800
200	200	2	2 000
250	250	2,5	2 000
315	315	3,2	2 000

Table 18 — Drop height and mass of striker for impact resistance
 (series based on inch dimensions)

Dimensions in millimetres

Nominal size DN/OD	Nominal outside diameter d_n	Mass of striker kg	Drop height of striker
36	36	0,5	600
43	43	0,5	800
56	56	0,5	1 000

7.2 Additional characteristics

Pipes intended to be used in areas where installation is usually carried out at temperatures below $-10\text{ }^{\circ}\text{C}$ shall additionally conform to the requirements of an impact test (staircase method), as specified in Table 19.

The pipes shall be marked in accordance with Table 23.

Table 19 — Additional mechanical characteristics of pipes

Characteristic	Requirements	Test parameters		Test method
Impact resistance (staircase method)	$H_{50} \geq 1\text{ m}$ Max. 1 break below 0,5 m	Conditioning and test temperature	0 °C	EN 1411
		Type of striker	Type d90	
		Mass of striker for:		
		32 mm $\leq d_n \leq$ 43 mm	1,25 kg	
		50 mm $\leq d_n \leq$ 63 mm	2 kg	
		75 mm $\leq d_n \leq$ 82 mm	2,5 kg	
		90 mm $\leq d_n \leq$ 100 mm	3,2 kg	
		$d_n = 110\text{ mm}$	4 kg	
		$d_n = 125\text{ mm}$	5 kg	
		$d_n = 140\text{ mm}$	6,3 kg	
		$d_n = 160\text{ mm}$	8 kg	
		$d_n = 180\text{ mm}$	8 kg	
$d_n = 200\text{ mm}$	10 kg			
$d_n \geq 250\text{ mm}$	12,5 kg			

8 Physical characteristics

8.1 Physical characteristics of pipes

When determined in accordance with the methods specified in Table 20, using the parameters indicated, the physical characteristics of pipes shall conform to the requirements given in Table 20.

Table 20 — Physical characteristics of pipes

Characteristic	Requirements	Test parameters		Test method
Vicat softening temperature (VST)	≥ 79 °C	Shall conform to EN 727		EN 727
Longitudinal reversion ^a	≤ 5 % The pipe shall exhibit no bubbles or cracks	Temperature	150 °C	EN 743 Method A: Liquid
		Immersion time	15 min	
		or		Temperature
Immersion time	30 min			
Resistance to dichloromethane at a specified temperature	No attack at any part of the surface of the test piece	Temperature	15 °C	EN 580
Immersion time	30 min			

^a The choice of method A or method B is in the responsibility of the manufacturer.

8.2 Physical characteristics of fittings

When determined in accordance with the methods specified in Table 21, using the parameters indicated, the physical characteristics of fittings shall conform to the requirements given in Table 21.

Table 21 — Physical characteristics of fittings

Characteristic	Requirements	Test parameters		Test method
Vicat softening temperature (VST)	≥ 79 °C	Shall conform to EN 727		EN 727
Effects of heating	^a and ^b	Temperature	150 °C	EN 763 Method A: Air oven
		Heating time	30 min	

^a

- 1) Within a radius of 15 times the wall thickness around the injection point, the depth of any cracks, delamination or blisters shall not exceed 50 % of the wall thickness at that point.
- 2) Within a distance of 10 times the wall thickness from the diaphragm zone, the depth of any cracks, delamination or blisters shall not exceed 50 % of the wall thickness in that zone.
- 3) Within a distance of 10 times the wall thickness from the ring gate, the length of any cracks shall not exceed 50 % of the wall thickness at that point.
- 4) The weld line shall not have opened by more than 50 % of the wall thickness at the line.
- 5) In all other parts of the surface, the depth of any cracks or delamination shall not exceed 30 % of the wall thickness at that point. Blisters shall not exceed a length 10 times the wall thickness.

^b After cutting through the fitting, the cut surfaces, when viewed without magnification, shall show no foreign particles.

9 Performance requirements

When determined in accordance with the methods specified in Table 22, using the parameters indicated, the fitness-for-purpose characteristics of the joints and the system shall conform to the requirements given in Table 22.

Table 22 — Fitness-for-purpose characteristics of the system

Characteristic	Requirements	Test parameters	Test method
Watertightness	No leakage	Shall conform to EN 1053	EN 1053
Airtightness	No leakage	Shall conform to EN 1054	EN 1054
Elevated-temperature cycling	No leakage Sagging for $DN \leq 50$: ≤ 3 mm Sagging for $DN > 50$: $\leq 0,05d_n$	Shall conform to EN 1055	Test assembly a) (Figure 1 and/or 3) of EN 1055:1996

10 Sealing rings

Sealing rings shall not have any detrimental effect on the properties of the pipe or fitting and shall not cause the test assembly to fail to conform to Table 22.

Materials for sealing rings shall conform to EN 681-1 or EN 681-2, as applicable.

11 Adhesives

The adhesive used shall be solvent cement, either as specified by the manufacturer of the pipes or fittings or as covered by a third-party agreement.

The adhesive shall not have any detrimental effect on the properties of the pipe or fitting and shall not cause the test assembly to fail to conform to Table 22.

12 Marking

12.1 General

12.1.1 Marking elements shall be labelled or printed or formed directly on the pipe or fitting and/or labelled or printed on the packaging.

12.1.2 Marking on a pipe or fitting shall not initiate cracks or other defects likely to prevent conformity to the requirements of this International Standard.

12.2 Minimum required marking of pipes

The minimum marking required for pipes is as specified in Table 23.

Pipes shall be marked at intervals of, at the maximum, 1 m, and at least once per pipe.

Table 23 — Minimum required marking of pipes

Item	Marking or symbol
Number of this International Standard	ISO 3633
Manufacturer's name and/or trade mark	XXX
Nominal size	e.g. DN 110
Minimum wall thickness	e.g. 3,2
Material	PVC or PVC-U
Manufacturer's information	^a
Cold-climate performance ^b	* (ice crystal)
^a To ensure traceability, the following details shall be given: <ul style="list-style-type: none"> – the production period (year and month), in figures or in code; – a name or code for the production site if the manufacturer is producing at different sites. 	
^b This marking is only applicable to pipes which have been proved, by testing, to conform to 7.2.	

12.3 Minimum required marking of fittings

The minimum marking required for fittings is as specified in Table 24.

Table 24 — Minimum required marking of fittings

Item	Marking or symbol
On the fitting:	
— Manufacturer's name and/or trade mark	XXX
— Nominal size	e.g. DN 110
— Nominal angle	e.g. 67°30'
— Material	PVC or PVC-U
On the fitting or on the packaging:	
— Number of this International Standard	ISO 3633
— Manufacturer's information	^a
— Solvent cement only	e.g. S.C.O.
— Socket type for sealing	S or M or L
^a To ensure traceability, the following details shall be given: <ul style="list-style-type: none"> – the production period (year and month), in figures or in code; – a name or code for the production site if the manufacturer is producing at different sites. 	

13 Installation of piping systems

For the installation of pipes and fittings conforming to this International Standard, national and/or local requirements and relevant codes of practice shall apply.

In addition, the pipe manufacturer may give a recommended practice for installation which covers the transport, storage and handling of the pipes and fittings as well as their installation in accordance with the applicable national and/or local instructions.

For external above-ground applications, additional requirements depending on the climate shall be agreed between the manufacturer and the purchaser.

Guidance on installation may be found in ISO/TR 7024.

Bibliography

- [1] ISO/TR 7024, *Above-ground drainage — Recommended practice and techniques for the installation of unplasticized polyvinyl chloride (PVC-U) sanitary pipework for above-ground systems inside buildings*

SLS 1325:2007

ISO 3633:2002(E)

ICS 83.140.30; 91.140.80

Price based on 29 pages

© ISO 2002 – All rights reserved

SRI LANKA STANDARDS INSTITUTION

The Sri Lanka Standards Institution (SLSI) is the National Standards Organization of Sri Lanka established under the Sri Lanka Standards Institution Act No. 6 of 1984 which repealed and replaced the Bureau of Ceylon Standards Act No. 38 of 1964. The Institution functions under the Ministry of Science & Technology.

The principal objects of the Institution as set out in the Act are to prepare standards and promote their adoption, to provide facilities for examination and testing of products, to operate a Certification Marks Scheme, to certify the quality of products meant for local consumption or exports and to promote standardization and quality control by educational, consultancy and research activity.

The Institution is financed by Government grants, and by the income from the sale of its publications and other services offered for Industry and Business Sector. Financial and administrative control is vested in a Council appointed in accordance with the provisions of the Act.

The development and formulation of National Standards is carried out by Technical Experts and representatives of other interest groups, assisted by the permanent officers of the Institution. These Technical Committees are appointed under the purview of the Sectoral Committees which in turn are appointed by the Council. The Sectoral Committees give the final Technical approval for the Draft National Standards prior to the approval by the Council of the SLSI.

All members of the Technical and Sectoral Committees render their services in an honorary capacity. In this process the Institution endeavours to ensure adequate representation of all view points.

In the International field the Institution represents Sri Lanka in the International Organization for Standardization (ISO), and participates in such fields of standardization as are of special interest to Sri Lanka.

SLS CERTIFICATION MARK

The Sri Lanka Standards Institution is the owner of the registered certification mark shown below. Beneath the mark, the number of the Sri Lanka Standard relevant to the product is indicated. This mark may be used only by those who have obtained permits under the SLS certification marks scheme. The presence of this mark on or in relation to a product conveys the assurance that they have been produced to comply with the requirements of the relevant Sri Lanka Standard under a well designed system of quality control inspection and testing operated by the manufacturer and supervised by the SLSI which includes surveillance inspection of the factory, testing of both factory and market samples.

Further particulars of the terms and conditions of the permit may be obtained from the Sri Lanka Standards Institution, 17, Victoria Place, Elvitigala Mawatha, Colombo 08.

