

SLS ISO 11363 PART 1: 2021
(= ISO 11363-1:2018)
UDC 696.2

GAS CYLINDERS –
17E AND 25E TAPER THREADS FOR
CONNECTION OF VALVES TO GAS
CYLINDERS –
PART 1: SPECIFICATIONS

SRI LANKA STANDARDS INSTITUTION

**GAS CYLINDERS - 17E AND 25E TAPER THREADS FOR CONNECTION OF
VALVES TO GAS CYLINDERS - PART 1: SPECIFICATIONS**

**SLS ISO 11363 PART 1: 2021
(= ISO 11363-1:2018)**

Gr. E

**SRI LANKA STANDARDS INSTITUTION
17, Victoria Place
Elvitigala Mawatha
Colombo 8
Sri Lanka.**

Sri Lanka Standards are subject to periodical revision in order to accommodate the progress made by industry. Suggestions for improvement will be recorded and brought to the notice of the Committees to which the revisions are entrusted.

This Standard does not purport to include all the necessary provisions of a contract

© SLSI 2021

All right reserved. Unless otherwise specified, no part of this publication may be reproduced or utilized in any form or by any means, electronic or mechanical, including photocopying and microfilm, without permission in writing from the SLSI.

Sri Lanka Standard
GAS CYLINDERS - 17E AND 25E TAPER THREADS FOR CONNECTION OF VALVES TO
GAS CYLINDERS - PART 1 : SPECIFICATIONS.

NATIONAL FOREWORD

This draft standard was approved by the Sectoral Committee on Materials, Mechanical systems and Manufacturing Engineering and was authorized for adoption and publication as a Sri Lanka Standard by the Council of the Sri Lanka Standards Institution on 2021- 04 - 30.

This standard is identical with ISO 11363: 2018, Gas cylinders - 17E and 25E taper threads for connection of valves to gas cylinders - Part 1: Specifications., published by International Standardization Organization (ISO).

This standard specifies the requirements for the dimensions and tolerances for taper screw threads of nominal diameter 17.4mm (designated as 17E) and 25.8mm (designated as 25E) used for the connection of valves to gas cylinders.

TERMINOLOGY AND CONVENTIONS

The text of the International Standard has been accepted as suitable for publication, without deviation, as a Sri Lanka Standard. However, certain terminology and conventions are not identical with those used in Sri Lanka Standards. Attention is therefore drawn to the following;

- a) Wherever the word “International Standard” appear referring to this standard should be interpreted as “Sri Lanka Standard”.
- b) The comma has been used throughout as a decimal marker. In Sri Lanka standard it is the current practice to use the full point at the basic as the decimal marker.
- c) Wherever page numbers are quoted, they are ISO page numbers.

CROSS REFERENCES

There are no cross references in this document.

INTERNATIONAL
STANDARD

ISO
11363-1

Second edition
2018-01

**Gas cylinders — 17E and 25E taper
threads for connection of valves to gas
cylinders —**

**Part 1:
Specifications**

*Bouteilles à gaz — Filetages coniques 17E et 25E pour le
raccordement des robinets sur les bouteilles à gaz —*

Partie 1: Spécifications



Reference number
ISO 11363-1:2018(E)

© ISO 2018



COPYRIGHT PROTECTED DOCUMENT

© ISO 2018

All rights reserved. Unless otherwise specified, or required in the context of its implementation, no part of this publication may be reproduced or utilized otherwise in any form or by any means, electronic or mechanical, including photocopying, or posting on the internet or an intranet, without prior written permission. Permission can be requested from either ISO at the address below or ISO's member body in the country of the requester.

ISO copyright office
CP 401 • Ch. de Blandonnet 8
CH-1214 Vernier, Geneva, Switzerland
Tel. +41 22 749 01 11
Fax +41 22 749 09 47
copyright@iso.org
www.iso.org

Published in Switzerland

Contents

Page

Foreword	iv
Introduction	v
1 Scope	1
2 Normative references	1
3 Terms and definitions	1
4 Requirements	4
4.1 Thread rotation.....	4
4.2 Taper.....	4
4.3 Thread profile.....	4
4.4 Pitch, <i>P</i>	4
4.5 Dimensions.....	4
5 Thread end finish	6
6 Marking	8
Bibliography	9

Foreword

ISO (the International Organization for Standardization) is a worldwide federation of national standards bodies (ISO member bodies). The work of preparing International Standards is normally carried out through ISO technical committees. Each member body interested in a subject for which a technical committee has been established has the right to be represented on that committee. International organizations, governmental and non-governmental, in liaison with ISO, also take part in the work. ISO collaborates closely with the International Electrotechnical Commission (IEC) on all matters of electrotechnical standardization.

The procedures used to develop this document and those intended for its further maintenance are described in the ISO/IEC Directives, Part 1. In particular the different approval criteria needed for the different types of ISO documents should be noted. This document was drafted in accordance with the editorial rules of the ISO/IEC Directives, Part 2 (see www.iso.org/directives).

Attention is drawn to the possibility that some of the elements of this document may be the subject of patent rights. ISO shall not be held responsible for identifying any or all such patent rights. Details of any patent rights identified during the development of the document will be in the Introduction and/or on the ISO list of patent declarations received (see www.iso.org/patents).

Any trade name used in this document is information given for the convenience of users and does not constitute an endorsement.

For an explanation on the voluntary nature of standards, the meaning of ISO specific terms and expressions related to conformity assessment, as well as information about ISO's adherence to the World Trade Organization (WTO) principles in the Technical Barriers to Trade (TBT) see the following URL: www.iso.org/iso/foreword.html.

This document was prepared by Technical Committee ISO/TC 58, *Gas cylinders*, Subcommittee SC 2, *Cylinder fittings*.

This second edition cancels and replaces the first edition (ISO 11363-1:2010), which has been technically revised to allow option C by modifying [Figure 2](#). It also incorporates the Technical Corrigenda ISO 11363-1:2010/Cor 1:2011 and ISO 11363-1:2010/Cor 2:2012.

A list of all parts in the ISO 11363 series can be found on the ISO website.

Introduction

Gas cylinders intended to contain compressed, liquefied or dissolved gas under pressure are fitted with accessories to allow release and refilling of gas. Hereinafter, the term “valve” will apply to such accessories.

Where the connection between cylinder and valve is obtained by assembly of two taper threads (and external one on the valve stem and an internal one in the cylinder neck), both will have the same nominal taper, thread pitch and thread profile.

Gas cylinders — 17E and 25E taper threads for connection of valves to gas cylinders —

Part 1: Specifications

1 Scope

This document specifies dimensions and tolerances for taper screw threads of nominal diameter 17,4 mm (designated as 17E) and 25,8 mm (designated as 25E) used for the connection of valves to gas cylinders.

It does not cover the connection requirements for

- mechanical strength,
- gas tightness, and
- capability of repeated assembly and dismounting operations.

Gauge inspection is covered by ISO 11363-2.

2 Normative references

There are no normative references in this document.

3 Terms and definitions

For the purposes of this document, the following terms and definitions apply.

ISO and IEC maintain terminological databases for use in standardization at the following addresses:

- IEC Electropedia: available at <http://www.electropedia.org/>
- ISO Online browsing platform: available at <http://www.iso.org/obp>

3.1 General

3.1.1

basic profile

theoretical profile, when the profile of the external thread coincides with the profile of the internal thread

3.1.2

design profile

profile which differs from the basic profile due to the radius of the root, necessary for manufacturing and strength requirements

Note 1 to entry: For such a profile, manufacturing tolerances are taken into account.

3.1.3
length of external thread

l_2
length of full form thread on the *valve stem* (3.1.8), measured along the cone axis from the *reference plane A* (3.4.3)

Note 1 to entry: See [Figure 1](#), [Table 1](#) and [Table 3](#).

3.1.4
length of internal thread

L_2
length of full form thread in the cylinder neck, measured along the cone axis from the *reference plane F* (3.4.5)

Note 1 to entry: See [Figure 1](#), [Table 2](#) and [Table 4](#).

3.1.5
pitch

P
distance, measured parallel to the cone surface, between two homologous points of two parallel consecutive flanks of the same thread

Note 1 to entry: See [Figures 2](#) and [3](#).

3.1.6
taper

ratio of the difference of two diameters corresponding to planes normal to the axis of the reference cone, and the axial distance between the same planes

Note 1 to entry: Taper can be expressed as a ratio, as an angle or as a percentage.

3.1.7
thread profile

thread shape obtained by the intersection of a plane through the thread axis and the threaded surface

3.1.8
valve stem

tapered end of the valve body (inlet connection), with a thread formed on the external surface of the truncated cone

Note 1 to entry: See [Figure 1](#).

3.1.9
cylinder neck thread

tapered axial hole in the cylinder neck, with a thread formed on the internal surface of the truncated cone

Note 1 to entry: See [Figure 1](#).

3.2 Terms relating to cones

3.2.1
major cone

cone bounding the crests of the thread of the *valve stem* (3.1.8), or the roots of the *cylinder neck thread* (3.1.9)

3.2.2
minor cone

cone bounding the roots of the thread, of the *valve stem* (3.1.8), or the crests of the *cylinder neck thread* (3.1.9)

3.2.3

pitch cone

cone passing coaxially and midway between the *major* (3.2.1) and *minor cones* (3.2.2)

3.3 Terms relating to diameter (see Figure 1)

3.3.1

major diameter

d_{1e}

diameter of the *major cone* (3.2.1) at the *valve stem* (3.1.8) thread *reference plane A* (3.4.3) (before any chamfer is cut)

3.3.2

major diameter

D_{1e}

diameter of the *major cone* (3.2.1) at *reference plane G* (3.4.6)

3.3.3

minor diameter

d_{1i}

diameter of the *minor cone* (3.2.2) at the *valve stem* (3.1.8) thread *reference plane A* (3.4.3) (before any chamfer is cut)

3.3.4

minor diameter

D_{1i}

diameter of the *minor cone* (3.2.2) at *reference plane G* (3.4.6)

3.3.5

pitch diameter

d_{1p}

diameter of the *pitch cone* (3.2.3) at the *valve stem* (3.1.8) thread *reference plane A* (3.4.3) (before any chamfer is cut)

3.3.6

pitch diameter

d_{2p}

diameter of the *pitch cone* (3.2.3) at *reference plane B* (3.4.4)

3.3.7

pitch diameter

D_{1p}

diameter of the *pitch cone* (3.2.3) at *reference plane G* (3.4.6)

3.3.8

pitch diameter

D_{2p}

diameter of the *pitch cone* (3.2.3) at *reference plane F* (3.4.5) (before any chamfer is cut)

3.4 Terms relating to reference (see Figure 1)

3.4.1

reference length

l_1

reference dimension being the distance between the parallel *reference planes A* (3.4.3) and *B* (3.4.4)

3.4.2

reference length

L_1

reference dimension being the distance between the parallel *reference planes F* (3.4.5) and *G* (3.4.6)

3.4.3

reference plane A

reference plane coincident with the small end face of the threaded *valve stem* (3.1.8) and corresponding to diameters d_{1i} (3.3.3), d_{1p} (3.3.5) and d_{1e} (3.3.1)

3.4.4

reference plane B

reference plane at a distance l_1 (3.4.1) from *reference plane A* (3.4.3) and corresponding to diameter d_{2p} (3.3.6)

3.4.5

reference plane F

reference plane coincident with the entry section face of the *cylinder neck thread* (3.1.9) and corresponding to *pitch diameter* D_{2p} (3.3.8)

3.4.6

reference plane G

reference plane at a distance L_1 (3.4.2) from *reference plane F* (3.4.5) and corresponding to diameter D_{1e} (3.3.2), D_{1p} (3.3.7) and D_{1i} (3.3.4)

4 Requirements

4.1 Thread rotation

The thread shall be a right-hand thread, such that it moves away from an observer when rotated clockwise.

4.2 Taper

The nominal values for the taper are the following:

- taper ratio: 3/25;
- taper angle: 6° 52';
- taper slope: 12 %.

4.3 Thread profile

The thread profile is a British Standard Whitworth (BSW) form with a 55° angle. The form and thread height measurements are perpendicular to the cone surface (see [Figure 3](#)).

NOTE BSW is a coarse thread devised and standardized in 1841 by British engineer Sir Joseph Whitworth (1803-87). It has an angle of thread of 55° and ranges in size from 1/16 in to 2 1/2 in. It is used in many types of engineering throughout the world, although in the UK, its use is now being superseded by the ISO metric system (see ISO 68-1).

It is crucial that the thread profile is cut in this way and not perpendicular to the axis of the cone.

4.4 Pitch, P

The nominal pitch is 1,814 mm (derived from $\frac{25,4}{14}$ mm) (see [Figure 3](#)).

4.5 Dimensions

Dimensions are given in [Figure 1](#) and the values are given in [Table 4](#).

Dimensions in millimetres

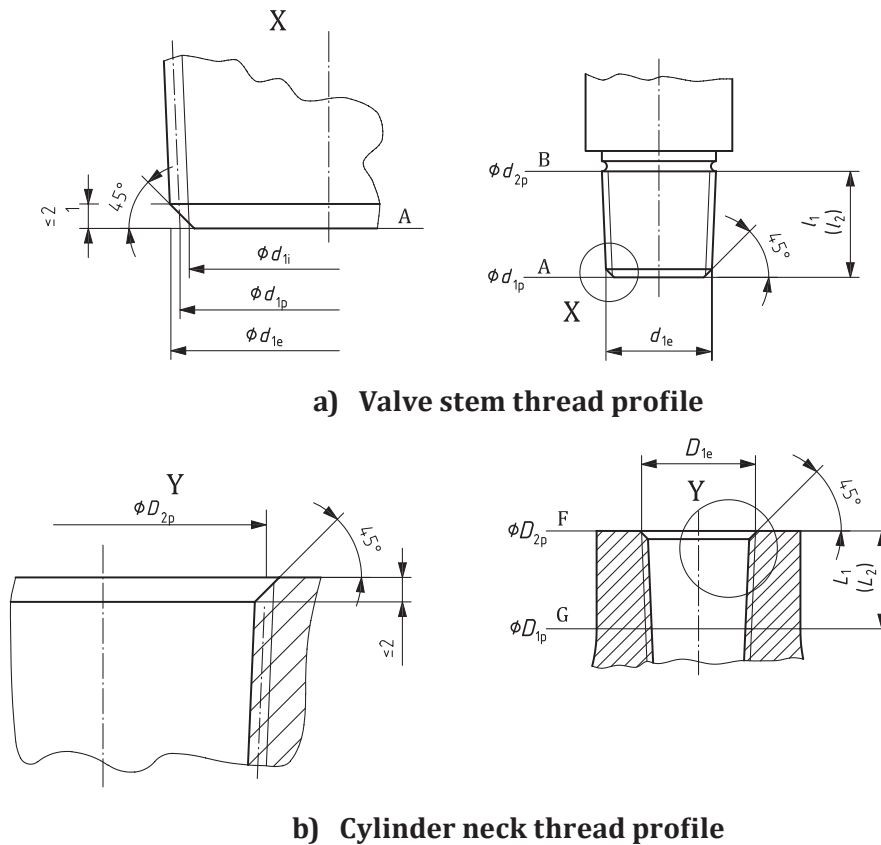

Key

D_{1p}, D_{2p}	pitch diameter	A	reference plane, A
L_1, l_1, l_2	reference length	B	reference plane, B
L_2	length of internal thread	F	reference plane, F
d_{1e}	major diameter	G	reference plane, G
d_{1i}	minor diameter		
d_{1p}	pitch diameter		
d_{2p}	pitch diameter		

Figure 1 — Thread reference planes and diameters

Table 1 — Valve stem thread dimensions for 17E

Dimensions in millimetres

Valve stem	Major diameter	Pitch diameter	Minor diameter	Pitch diameter	Reference length	Minimum length of full form thread
	d_{1e}	d_{1p}	d_{1i}	d_{2p}	l_1	l_2
Dimension	17,28	16,118	14,956	18,638	21	≥ 21
Tolerance	+0,12 0	+0,12 0	+0,12 0	+0,12 0	—	—

Table 2 — Cylinder neck thread dimensions for 17E

Dimensions in millimetres

Cylinder neck thread	Major diameter D_{1e}	Pitch diameter D_{1p}	Minor diameter D_{1i}	Pitch diameter D_{2p}	Reference length L_1	Minimum length of full form thread L_2
Dimension	17,16	15,998	14,834	18,038	17	≥17
Tolerance	0 -0,12	0 -0,12	0 -0,12	0 -0,12	—	—

Table 3 — Valve stem thread dimensions for 25E

Dimensions in millimetres

Valve stem	Major diameter d_{1e}	Pitch diameter d_{1p}	Minor diameter d_{1i}	Pitch diameter d_{2p}	Reference length l_1	Minimum length of full form thread l_2
Dimension	25,68	24,518	23,356	27,638	26	≥26
Tolerance	+0,12 0	+0,12 0	+0,12 0	+0,12 0	—	—

Table 4 — Cylinder neck thread dimensions for 25E

Dimensions in millimetres

Cylinder neck thread	Major diameter D_{1e}	Pitch diameter D_{1p}	Minor diameter D_{1i}	Pitch diameter D_{2p}	Reference length L_1	Minimum length of full form thread L_2
Dimension	25,16	23,998	22,836	26,638	22	≥24
Tolerance	0 -0,12	0 -0,12	0 -0,12	0 -0,12	—	—

5 Thread end finish

The thread of the valve stem shall have a 45° chamfer positioned 1 mm to 2 mm (maximum) from reference plane A at the bottom part and a groove at the top (see [Figure 1](#)). The first thread (small end) shall be fully formed and shall exhibit maximum clearance (d_{1i} shall be minimum).

The thread of the cylinder neck shall have a 45° chamfered opening between 1 mm and 2 mm maximum from plane F (see [Figure 1](#)). The execution of the neck thread shall be as shown in [Figure 2](#).

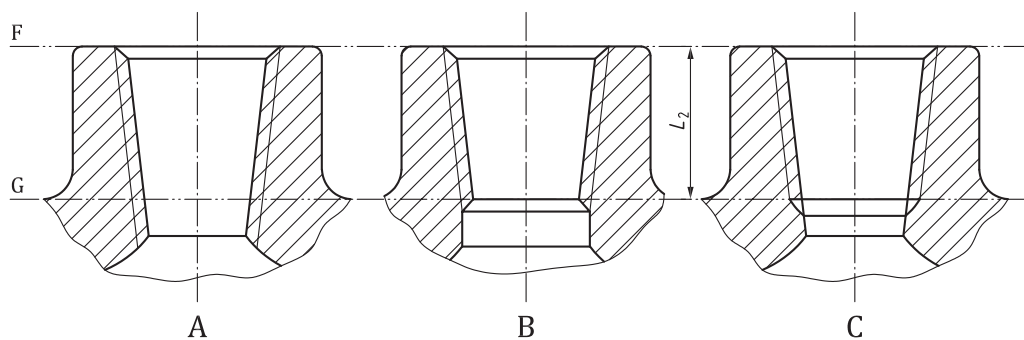

Key

- A option A
- B option B
- C option C
- L_2 length of internal thread
- F reference plane, F
- G reference plane, G

Figure 2 — Execution of cylinder neck threads

If option C is chosen, the taper hole shall be through-drilled into the cylinder before the thread is cut.

Dimensions in millimetres

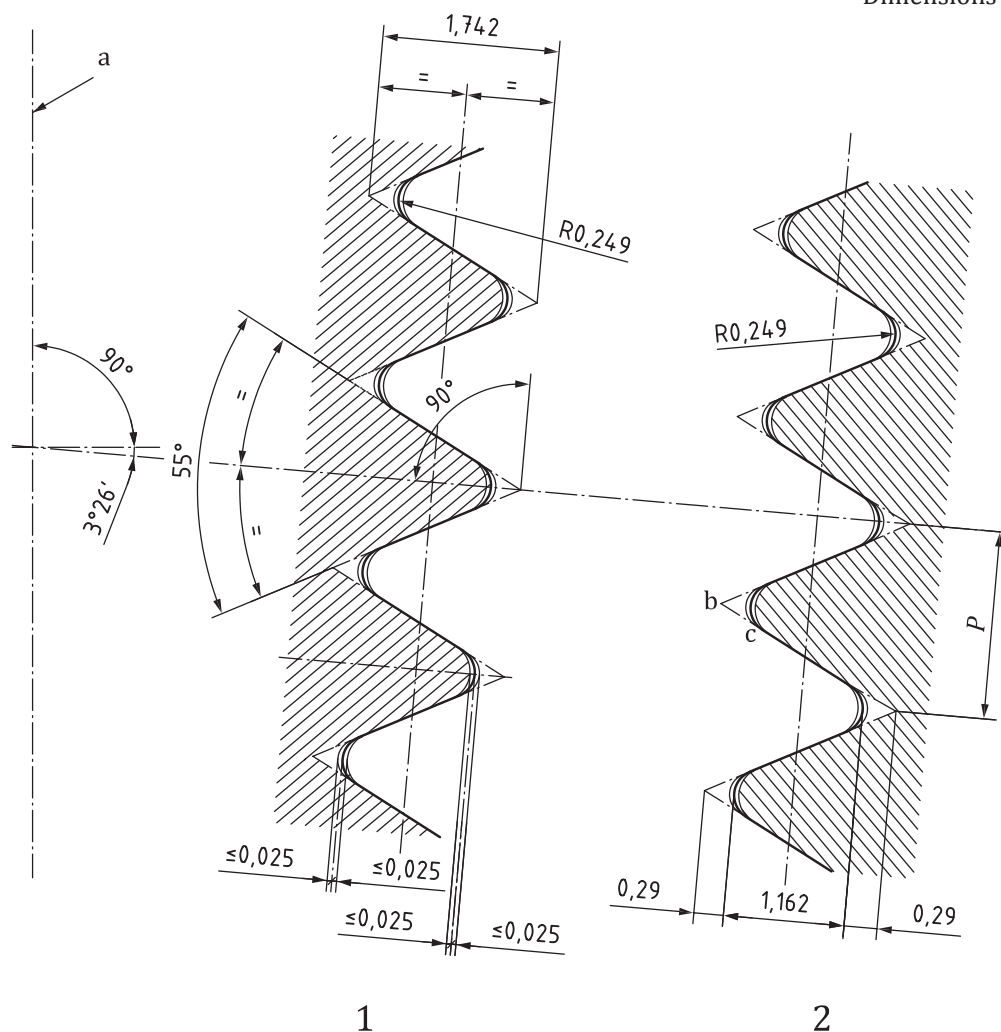

Key

- P pitch
- 1 valve stem thread profile
- 2 cylinder neck thread profile
- a Thread axis.
- b Basic profile.
- c Design profile.

Figure 3 — Thread profiles

6 Marking

Valves and cylinders threaded in accordance with this document shall be marked by the symbol “17E” or “25E” as applicable.

Bibliography

- [1] ISO 68-1, *ISO general purpose screw threads — Basic profile — Part 1: Metric screw threads*
- [2] ISO 10920¹⁾, *Gas cylinders — 25E taper thread for connection of valves to gas cylinders — Specification*
- [3] ISO 11116-1²⁾, *Gas cylinders — 17E taper thread for connection of valves to gas cylinders — Part 1: Specifications*
- [4] ISO 11363-2, *Gas cylinders — 17E and 25E taper threads for connection of valves to gas cylinders — Part 2: Gauge inspection*

1) Withdrawn and replaced by ISO 11363-1:2010.

2) Withdrawn and replaced by ISO 11363-1:2010.

SLS CERTIFICATION MARK

The Sri Lanka Standards Institution is the owner of the registered certification mark shown below. Beneath the mark, the number of the Sri Lanka Standard relevant to the product is indicated. This mark may be used only by those who have obtained permits under the SLS certification marks scheme. The presence of this mark on or in relation to a product conveys the assurance that they have been produced to comply with the requirements of the relevant Sri Lanka Standard under a well designed system of quality control inspection and testing operated by the manufacturer and supervised by the SLSI which includes surveillance inspection of the factory, testing of both factory and market samples.

Further particulars of the terms and conditions of the permit may be obtained from the Sri Lanka Standards Institution, 17, Victoria Place, Elvitigala Mawatha, Colombo 08.



SRI LANKA STANDARDS INSTITUTION

The Sri Lanka Standards Institution (SLSI) is the National Standards Organization of Sri Lanka established under the Sri Lanka Standards Institution Act No. 6 of 1984 which repealed and replaced the Bureau of Ceylon Standards Act No. 38 of 1964. The Institution functions under the Ministry of Science & Technology.

The principal objects of the Institution as set out in the Act are to prepare standards and promote their adoption, to provide facilities for examination and testing of products, to operate a Certification Marks Scheme, to certify the quality of products meant for local consumption or exports and to promote standardization and quality control by educational, consultancy and research activity.

The Institution is financed by Government grants, and by the income from the sale of its publications and other services offered for Industry and Business Sector. Financial and administrative control is vested in a Council appointed in accordance with the provisions of the Act.

The development and formulation of National Standards is carried out by Technical Experts and representatives of other interest groups, assisted by the permanent officers of the Institution. These Technical Committees are appointed under the purview of the Sectoral Committees which in turn are appointed by the Council. The Sectoral Committees give the final Technical approval for the Draft National Standards prior to the approval by the Council of the SLSI.

All members of the Technical and Sectoral Committees render their services in an honorary capacity. In this process the Institution endeavours to ensure adequate representation of all view points.

In the International field the Institution represents Sri Lanka in the International Organization for Standardization (ISO), and participates in such fields of standardization as are of special interest to Sri Lanka.