

SLS 1118 : 1995
ISO 8790 : 1987

Sri Lanka Standard
INFORMATION PROCESSING SYSTEMS – COMPUTER SYSTEM
CONFIGURATION DIAGRAM SYMBOLS AND CONVENTIONS

Gr. G

SRI LANKA STANDARDS INSTITUTION

SLS 1118 : 1995
ISO 8790 : 1987

Sri Lanka Standard
INFORMATION PROCESSING SYSTEMS - COMPUTER SYSTEM CONFIGURATION
DIAGRAM SYMBOLS AND CONVENTIONS

NATIONAL FOREWORD

This standard was approved by the Sectoral Committee on Information Technology on 1994.10.11 and was authorized for adoption and publication as a Sri Lanka Standard by the Council of Sri Lanka Standards Institution on 1995.12.14.

This Sri Lanka Standard is identical with ISO 8790 : 1987 Information processing systems - Computer system configuration diagram symbols and conventions, published by the International Organization for Standardization (ISO).

TERMINOLOGY AND CONVENTIONS

The text of the International Standard has been accepted as suitable for publication without deviation, as a Sri Lanka Standard. However, certain terminology and conventions are not identical with those used in Sri Lanka standards, attention is therefore drawn to the following;

a) Wherever the words "International standard" appear, referring to this standard, they should be interpreted as "Sri Lanka standard".

Wherever page numbers are quoted, they are ISO page numbers.

INTERNATIONAL STANDARD

**ISO
8790**

First edition
1987-09-01



INTERNATIONAL ORGANIZATION FOR STANDARDIZATION
ORGANISATION INTERNATIONALE DE NORMALISATION
МЕЖДУНАРОДНАЯ ОРГАНИЗАЦИЯ ПО СТАНДАРТИЗАЦИИ

Information processing systems — Computer system configuration diagram symbols and conventions

*Systèmes de traitement de l'information — Symboles et conventions s'appliquant aux
schémas des configurations de systèmes informatiques*

Foreword

ISO (the International Organization for Standardization) is a worldwide federation of national standards bodies (ISO member bodies). The work of preparing International Standards is normally carried out through ISO technical committees. Each member body interested in a subject for which a technical committee has been established has the right to be represented on that committee. International organizations, governmental and non-governmental, in liaison with ISO, also take part in the work.

Draft International Standards adopted by the technical committees are circulated to the member bodies for approval before their acceptance as International Standards by the ISO Council. They are approved in accordance with ISO procedures requiring at least 75 % approval by the member bodies voting.

International Standard ISO 8790 was prepared by Technical Committee ISO/TC 97, *Information processing systems*.

Users should note that all International Standards undergo revision from time to time and that any reference made herein to any other International Standard implies its latest edition, unless otherwise stated.

Contents	Page
1 Scope	1
2 Field of application	1
3 Configuration diagram symbols	1
3.1 Physical unit or its enclosure	1
3.2 Connection line	5
4 Conventions	6
4.1 Symbol shape	6
4.2 Connection lines	6
4.3 Identification of symbols	9
4.4 Representation of multiple units in a single enclosure	9
4.5 Proper use of symbols	10
4.6 Representation of a selection unit	10
4.7 Representation of future installations	10
4.8 Repetitive representation of the same units	11
4.9 Overlaid representation of different units	11
4.10 Representation of omission	11
5 Consolidated table of symbols	12

This page intentionally left blank

Information processing systems — Computer system configuration diagram symbols and conventions

1 Scope

This International Standard establishes graphical symbols and their conventions for use in configuration diagrams for computer systems, including automatic data processing systems.

2 Field of application

The graphical symbols included in this International Standard are intended to represent major hardware units of a computer system configuration. This International Standard does not cover:

- detailed representation of hardware, such as logical or electronic circuit diagrams;
- or pictorial type diagrams that utilize pictures or drawings to depict a system;
- nor does it include any abbreviations or mnemonics used to identify a specific kind of unit.

The configuration diagram is used to represent the physical structure of computer systems such as the physical equipment and the connection cables.

A configuration diagram can represent

- the maximum configuration in which all hardware units are included;
- the configuration resulting from reallocation of hardware units and temporary withdrawal of service;
- the minimum configuration necessary for the solution of a given problem;
- alternative configurations of the same equipment, etc.

The configuration diagram has many uses, namely:

- in commercial brochures of computer manufacturers;
- in selection and evaluation of computer configurations;
- in the technical clauses of computer contracts for purchase or lease;
- in the representation of a computer centre;
- in magazine articles describing data processing applications;
- in specifications of data processing applications;
- in education.

A configuration diagram consists of

- a) hardware symbols where each symbol represents a physical unit by its essential function;
- b) connection lines representing a local or distant (transmission line) physical connection;
- c) special conventions to facilitate the reading and the writing of the diagram.

3 Configuration diagram symbols

This clause defines the symbols for describing physical units and the means used to connect them. Additional methods used to facilitate the reading and writing of the diagram are defined in clause 4.

Four levels of symbols are presented to permit various levels of detail to be shown in the diagram. The highest level represents only physical units and their connections. The second level represents the principal functional units of computer systems, such as processors, storage, input-output units, communications units, and means of connection. The third level represents the basic types of media or means of input-output used for storage and input-output. The lowest level provides the most detailed distinction between the various kinds of units. (See consolidated table of symbols in clause 5.)

The same symbol is used at several different levels where there is no necessity for further details. Identification in such cases is supplied by the use of symbol identification (see 4.3).

3.1 Physical unit or its enclosure

These symbols are basic symbols representing any kind of physical unit or set of physical units. These symbols also represent an enclosure of a unit or set of units (see 4.4).

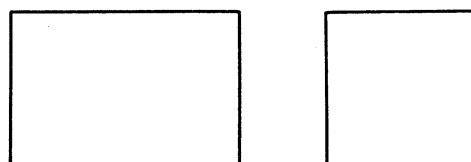

3.1.1 Processing or control unit

These symbols represent any kind of processing or control unit, for example, central processing unit, auxiliary processing unit, arithmetic unit, main storage control unit, auxiliary storage control unit, input-output control unit, communication control unit, configuration control unit, channel unit, communication node, modem, multi-component terminals, multi-component consoles.

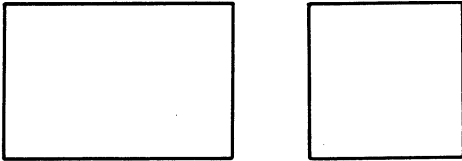

3.1.1.1 Processing or control unit

This symbol represents a processing or a control unit.

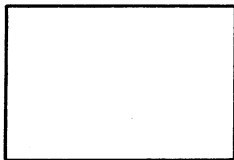

3.1.1.2 Selection unit

This symbol represents a selection unit.

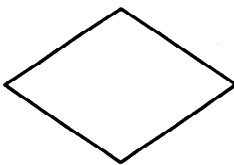

3.1.1.3 Conversion unit

This symbol is a generic symbol representing any kind of conversion unit; for example, sensor, modulator, decoder, concentrator.

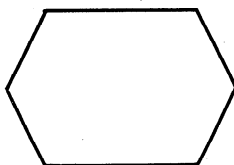

3.1.2 Storage unit

This symbol is a generic symbol representing any kind of storage unit.

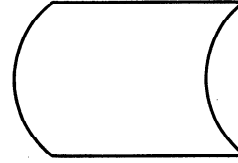

3.1.2.1 Main storage unit

This symbol represents a main storage unit.

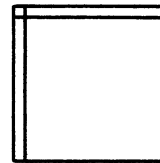

The basic symbols for a physical unit may be used if a suitable identifier is supplied; this is only used in depicting a composite item, as illustrated in 4.4c).

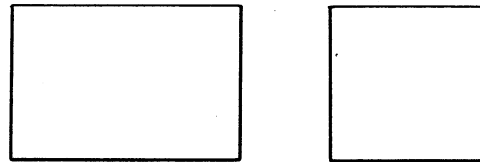

3.1.2.2 Sequential access storage unit

This symbol is a generic symbol representing any kind of sequential access storage unit which is only sequentially accessible; for example, magnetic tape unit, cartridge tape unit, cassette tape unit.

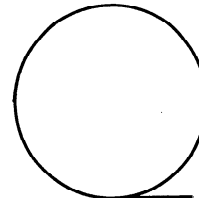

3.1.2.2.1 Magnetic tape unit

This symbol represents a magnetic tape unit.

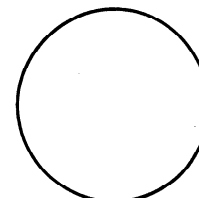

3.1.2.2.2 Cartridge or cassette unit

This symbol represents a cartridge or cassette unit.

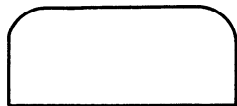

3.1.2.3 Direct access storage unit

This symbol is a generic symbol representing any kind of direct access storage unit; for example, magnetic disk pack unit, fixed disk unit, disk cartridge unit, drum unit, flexible disk unit.



3.1.2.3.1 Magnetic disk or drum unit

This symbol represents a magnetic disk or drum unit; for example, disk pack unit, fixed disk unit, disk cartridge unit, drum unit.

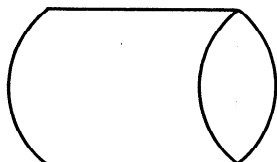

3.1.2.3.2 Flexible disk unit

This symbol represents a flexible disk unit.

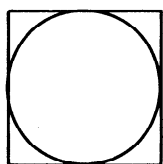

3.1.2.3.3 Solid-state or magnetic core peripheral unit

This symbol is a generic symbol representing any kind of solid-state or magnetic core peripheral storage unit; for example, CCD, magnetic core, or magnetic bubble peripheral storage unit.

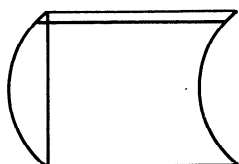

3.1.2.4 Mass storage unit

This symbol is a generic symbol representing any kind of mass storage unit; for example, tape-cartridge-based mass storage unit, optical disk storage unit, video disk storage unit, laser beam storage unit, electron beam storage unit.

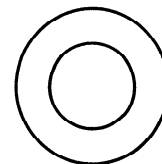

3.1.2.4.1 Mass storage unit

This symbol represents a mass storage unit.

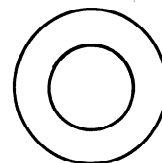

3.1.2.4.2 Tape-cartridge-based mass storage unit

This symbol represents a tape-cartridge-based mass storage unit.

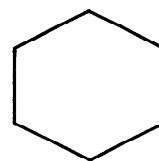

3.1.3 Input-output unit

This symbol is a generic symbol representing any kind of input-output unit.

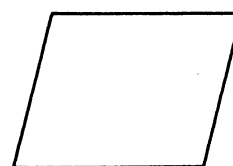

3.1.3.1 Input-output unit for human-readable document

This symbol is a generic symbol representing any kind of input-output unit for human-readable documents; for example, printer, OCR, MICR, microfilm, tally roll, X-Y plotter, facsimile, scanner.

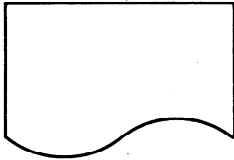

3.1.3.1.1 Printer

This symbol represents a printer.

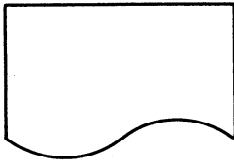

3.1.3.1.2 X-Y plotter

This symbol represents an X-Y plotter.

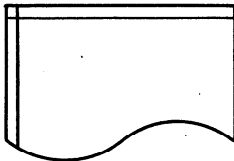

3.1.3.2 Manual input unit

This symbol is a generic symbol representing any kind of input unit where the information is entered manually at the time of processing; for example, online keyboard, switch, push button, light pen, bar-code wand, mouse, digitizer.



3.1.3.2.1 Online keyboard

This symbol represents an online keyboard.



3.1.3.3 Card unit

This symbol is a generic symbol representing any kind of card unit; for example, punched-card unit, magnetic card unit, mark-sense card unit, stub card unit, mark-scan card unit.



3.1.3.3.1 Punched card unit

This symbol represents a punched card unit.

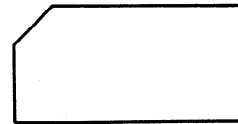

3.1.3.4 Punched tape unit

This symbol represents any kind of punched tape unit.

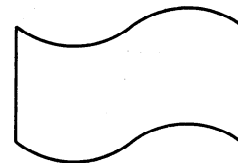

3.1.3.5 Display unit

This symbol is a generic symbol representing any kind of visual display unit for human use; for example, cathode-ray tube display unit, liquid quartz display unit, plasma display unit, display board, online indicator.

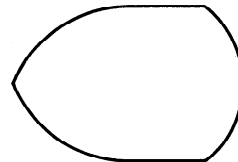

3.1.3.5.1 Cathode-ray tube display unit

This symbol represents a cathode-ray tube display unit.

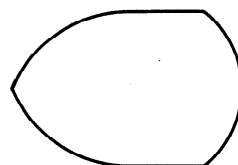

3.1.3.6 Sound input-output unit

This symbol is a generic symbol representing any kind of sound input-output unit; for example, telephone set, audio recognition unit, audio response unit.



3.1.3.6.1 Telephone set

This symbol represents a telephone set.

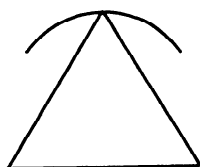

3.1.3.6.2 Audio recognition unit

This symbol represents an audio recognition unit.

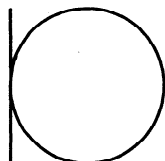

3.1.3.6.3 Audio response unit

This symbol represents an audio response unit.

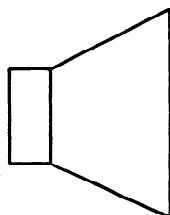

3.2 Connection line

This symbol is the basic symbol representing any connection, including a communication link.



3.2.1 Connecting cable

This symbol is a generic symbol representing any type of connecting cable.



3.2.1.1 Ordinary connecting cable

This symbol represents an ordinary connecting cable.



3.2.1.2 Bus connection

These symbols represent any kind of bus connection.

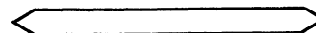
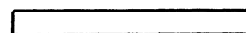

The ends of the parallel lines shall be closed.

The symbol on the bottom signifies that the bus can be extended.

3.2.2 Communication link

This symbol is a generic symbol representing any kind of communication link.



3.2.2.1 Wired transmission

This is a generic symbol representing a wired communication link.



3.2.2.2 Wireless transmission

This is a generic symbol representing a wireless communication link.



3.2.2.2.1 Single-channel wireless transmission

This symbol represents a single-channel wireless communication link.



3.2.2.2.2 Multi-channel wireless transmission

This symbol represents a multi-channel wireless communication link.



Thus, a satellite can be represented by combining the processing unit symbol and the wireless transmission symbol as illustrated.

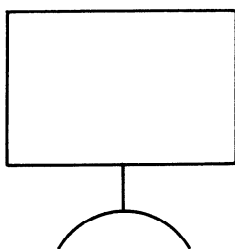

4 Conventions

4.1 Symbol shape

This International Standard does not give exact specifications for height and width ratios; the user shall not, however, vary these to such an extent that the symbol is not immediately recognizable.

Symbols may be drawn in any orientation, but the horizontal orientation should be preferred where possible. The mirror image of a shape implies the same function, but is not preferred.

4.2 Connection lines

4.2.1 Basic conventions for connection lines

- a) There is no preferred side for a connection line to enter or leave a symbol for a unit. Nor is any meaning implied in the direction a connection line takes. Also the position of units along a connection line does not imply any additional meaning unless otherwise clearly indicated. Multiple connection lines may be simplified to a single connection line.
- b) Arrows indicating the direction of flow may be used if necessary.
- c) An identifier or a description may be added to the connection line.
- d) The crossing and the junction of two or more connection lines are shown below. Crossing of lines means that they are not connected.

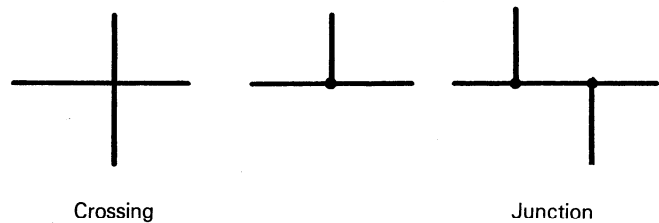

The junction mark (●) may be omitted when the junction cannot be interpreted as a crossing.

Example:

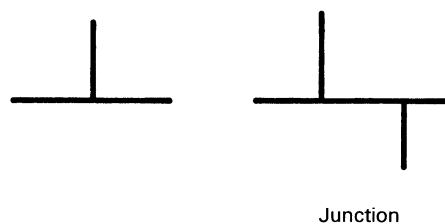

4.2.2 Common connections

Common connections may be depicted by multiple junctions to a single line or by the use of the bus symbol. The bus symbol, if used, shall be closed at the ends.

Example:

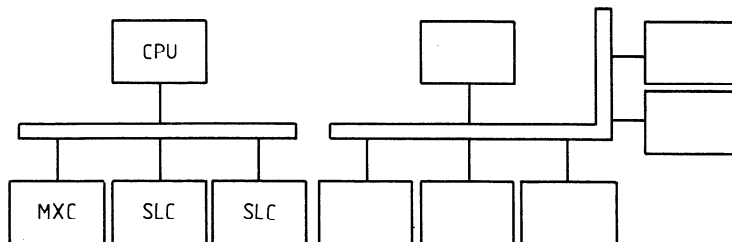

4.2.3 Representation of daisy-chained or star-burst connections

c) Star-burst connection may also be drawn as follows:

a) The following representation may be used for both daisy-chained and star-burst connections:

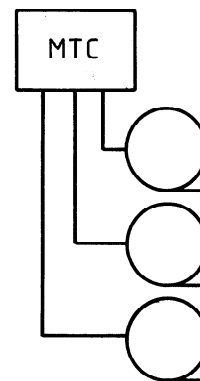
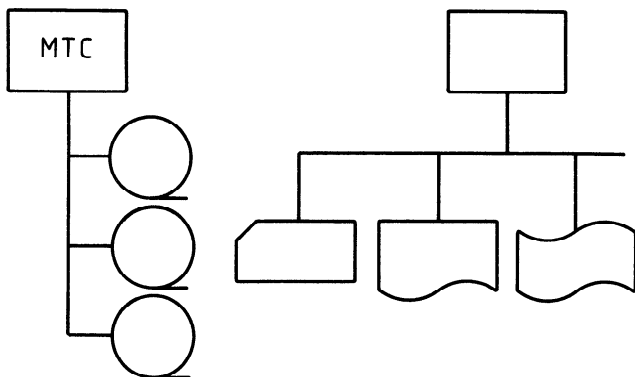

b) Daisy-chained connection may also be drawn as follows:

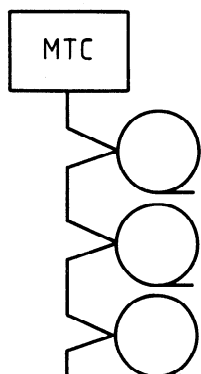

4.2.4 Representation of crosscall functions

a) When the crosscall function is contained in input-output units, the connection shall be drawn as follows:

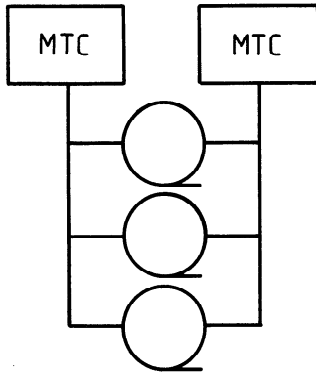

b) When the crosscall function is contained in control units, the connection shall be drawn as follows:

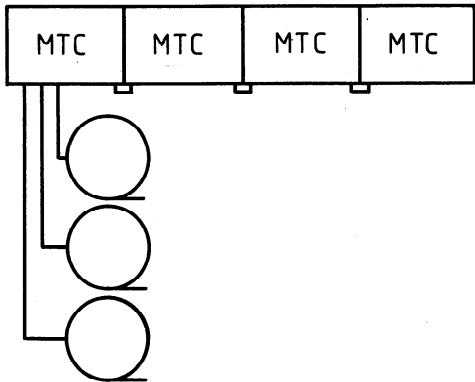

The above diagram may be simplified as shown in the following example. In this case, the crosscall function shall be clarified by the use of additional information.

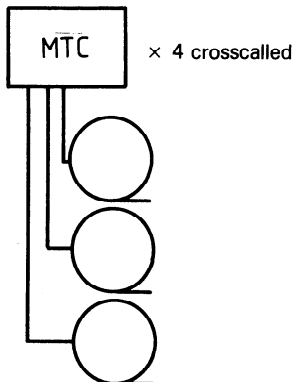

4.2.5 Representation of line continuation

When a connection line cannot be drawn directly between two units, the fact that the line is continued may be shown in the following way:



The same unique identifier shall be contained in the corresponding circles.

4.2.6 Representation of grouped connections

The fact that connections are physically grouped may be indicated as follows:



4.2.7 Omission of connection source or destination

The source or destination of a connection may be omitted but the fact that the connection exists should be made evident. For example:

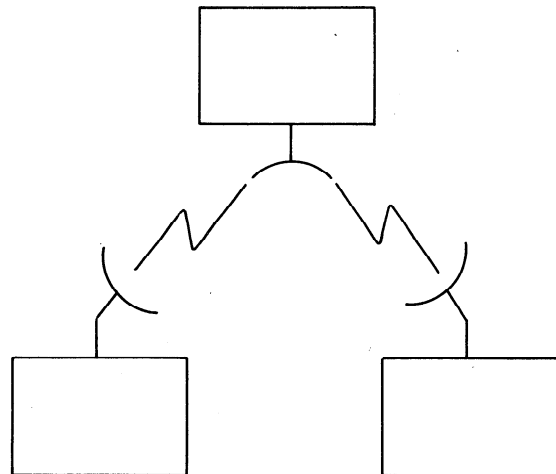

4.3 Identification of symbols

A symbol may be identified with a specific kind of unit or specific level of description by placing in or near the symbol the name, mnemonic, or model number for specific devices, or a generic name for higher levels of description (for example, node, major node, message switcher).

Examples:

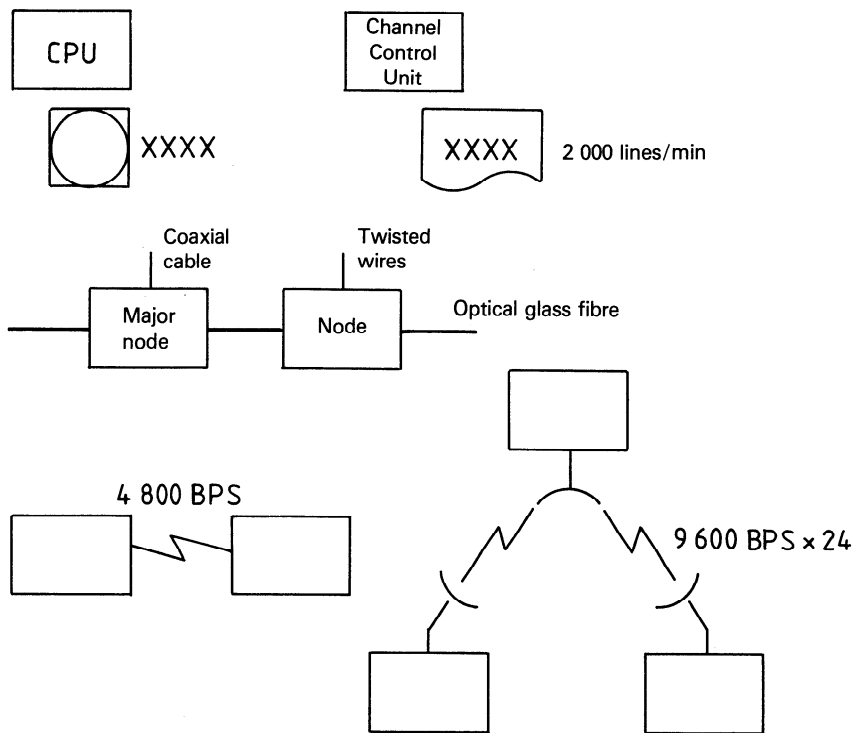

4.4 Representation of multiple units in a single enclosure

a) Multiple magnetic tape units may be drawn as follows:

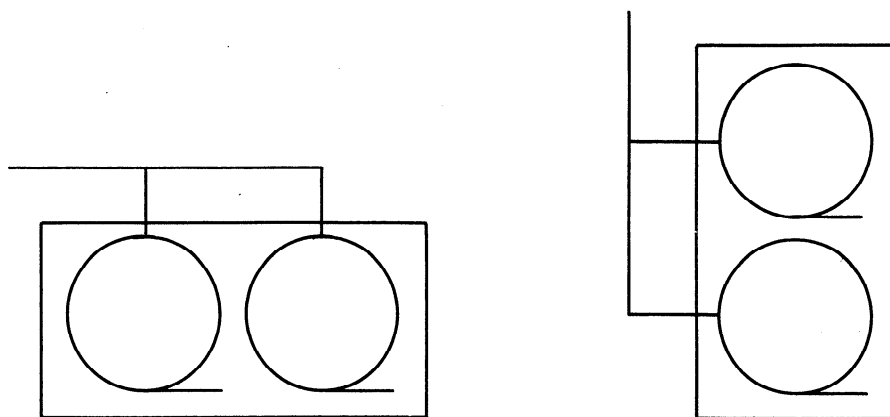

b) Multiple magnetic disk units may be drawn as follows:

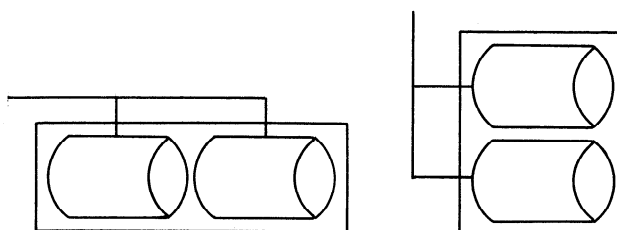

c) Multiple units, such as a central processor unit, storage unit, and channel units contained in a single enclosure, may be drawn as follows:

MSU		512 KB	
CPU			
B	M	S	S
M	X	L	L
C	C	C	C

4.5 Proper use of symbols

When an intelligent terminal or an input-output unit with multiple functions is to be represented as a single symbol, a symbol representing the principal input-output function shall be used.

Examples:

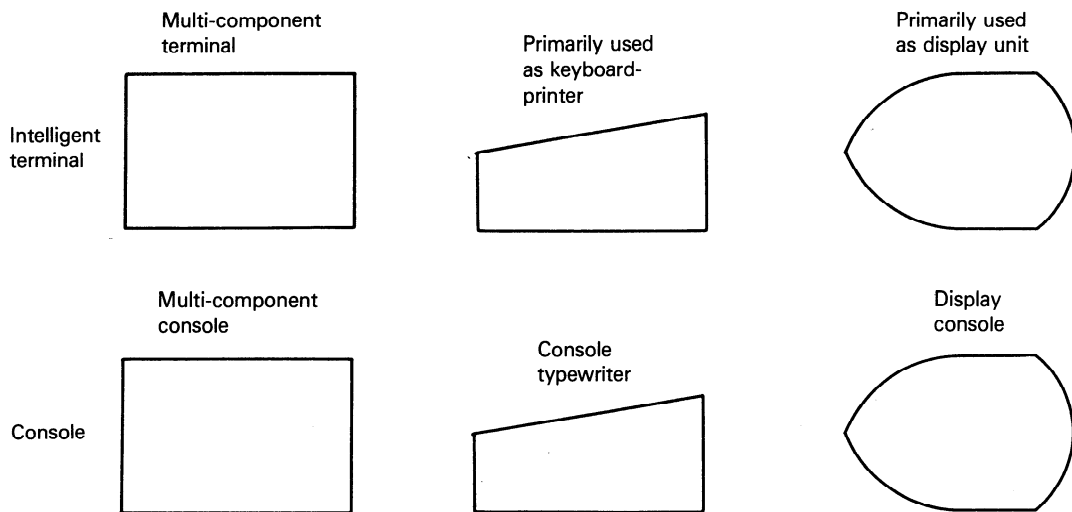

4.6 Representation of a selection unit

This symbol represents a selection unit which may take the form of a telephone exchange, message switching unit, device switch or a distributor.

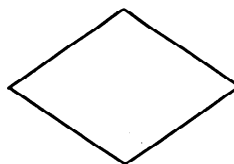

4.7 Representation of future installations

Units for installation some time in the future shall be represented by dotted lines.

Example:

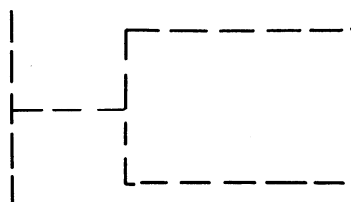

4.8 Repetitive representation of the same units

As an alternative to multiple, independent symbols, the same unit symbol may be shown in an overlay-pattern as shown below.

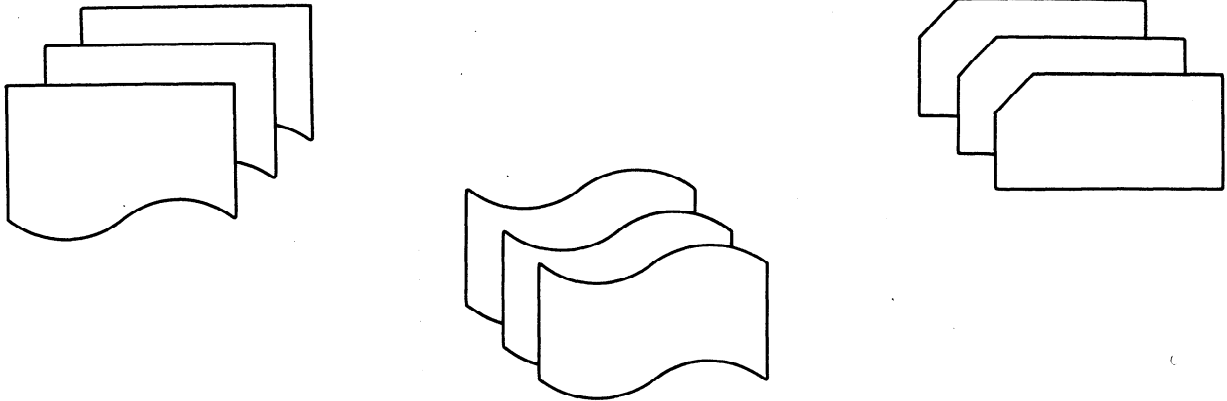

4.9 Overlaid representation of different units

If two different units are built or used together in such a way as to be a single unit for all practical purposes, they may be shown by an overlaid representation.

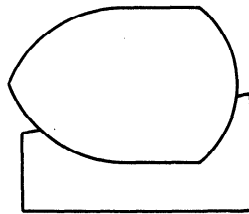





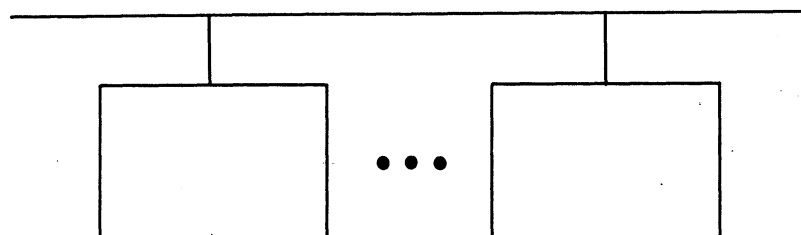



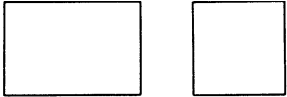

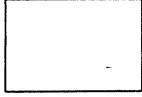
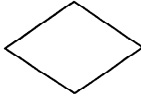

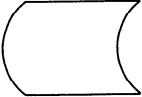
4.10 Representation of omission

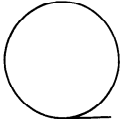
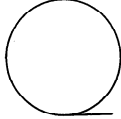
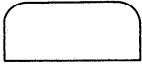
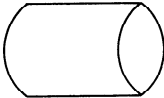
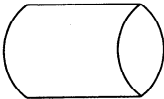



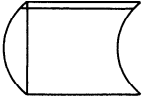
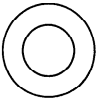

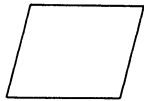
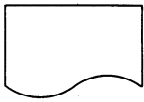
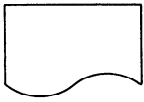
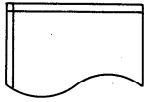
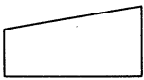
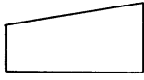
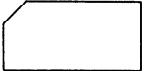
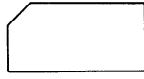





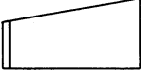

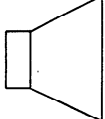
Ellipses may be used to represent the omission of symbols when graphical representation of the exact number of units is not required.

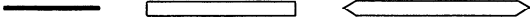

5 Consolidated table of symbols

Level 1	Level 2	Level 3	Level 4
<p>Physical unit or its enclosure (see 3.1)</p> 	<p>Processing or control unit (see 3.1.1)</p> 	<p>Processing or control unit (see 3.1.1.1)</p> 	
		<p>Selection unit (see 3.1.1.2)</p> 	
		<p>Conversion unit (see 3.1.1.3)</p> 	
	<p>Storage unit (see 3.1.2)</p> 	<p>Main storage unit (see 3.1.2.1)</p> 	<p>(See text for alternative representation)</p>
		<p>Sequential access storage unit (see 3.1.2.2)</p> 	<p>Magnetic tape unit (see 3.1.2.2.1)</p> 
			<p>Cartridge or cassette unit (see 3.1.2.2.2)</p> 
		<p>Direct access storage unit (see 3.1.2.3)</p> 	<p>Magnetic disk or drum unit (see 3.1.2.3.1)</p> 
			<p>Flexible disk unit (see 3.1.2.3.2)</p> 

Level 1	Level 2	Level 3	Level 4	
Physical unit or its enclosure <i>(continued)</i> (see 3.1)	Storage unit <i>(continued)</i> (see 3.1.2)	Direct access storage unit <i>(continued)</i> (see 3.1.2.3)	Solid-state or magnetic core peripheral unit (see 3.1.2.3.3) 	
		Mass storage unit (see 3.1.2.4)	Mass storage unit (see 3.1.2.4.1)	
			Tape-cartridge-based mass storage unit (see 3.1.2.4.2) 	
		Input-output unit (see 3.1.3)	Input-output unit for human-readable document (see 3.1.3.1)	Printer (see 3.1.3.1.1)
				X-Y plotter (see 3.1.3.1.2)
			Manual input unit (see 3.1.3.2)	Online keyboard (see 3.1.3.2.1)
Card unit (see 3.1.3.3)	Punched card unit (see 3.1.3.3.1)			
Punched tape unit (see 3.1.3.4)				
				
				
				
				

Level 1	Level 2	Level 3		Level 4
Physical unit or its enclosure <i>(continued)</i> (see 3.1)	Input-output unit <i>(continued)</i> (see 3.1.3)	Display unit (see 3.1.3.5) 	Cathode-ray tube display unit (see 3.1.3.5.1) 	
		Sound input-output unit (see 3.1.3.6) 	Telephone set (see 3.1.3.6.1) 	
			Audio recognition unit (see 3.1.3.6.2) 	
			Audio response unit (see 3.1.3.6.3) 	
Connection line (see 3.2) 	Connecting cable (see 3.2.1) 	Ordinary connecting cable (see 3.2.1.1) 		
		Bus connection (see 3.2.1.2) 		
	Communication link (see 3.2.2) 	Wired transmission (see 3.2.2.1) 		
		Wireless transmission (see 3.2.2.2) 	Single-channel wireless transmission (see 3.2.2.2.1) 	
	Multi-channel wireless transmission (see 3.2.2.2.2) 			

This page intentionally left blank

SLS 1118 : 1995

ISO 8790 : 1987 (E)

UDC 681.3.02 : 003.63

Descriptors : data processing, data processing equipment, data processing system configuration, schematic representation.

Price based on 14 pages
