

SRI LANKA STANDARD 1239 Part 1: 2011
IEC 61347-2-3: 2011

SPECIFICATION FOR
AC AND/OR DC- SUPPLIED ELECTRONIC
BALLAST FOR TUBULAR
FLUORESCENT LAMPS
PART 1: SAFETY REQUIREMENTS

SRI LANKA STANDARDS INSTITUTION

Sri Lanka Standard
SPECIFICATION FOR AC AND/OR DC- SUPPLIED ELECTRONIC BALLAST
FOR TUBULAR FLUORESCENT LAMPS
PART 1: SAFETY REQUIREMENTS

SLS 1239 Part 1: 2011
IEC 61347-2-3: 2011

Gr.S

Copyright Reserved
SRI LANKA STANDARDS INSTITUTION
No. 17, Victoria Place,
Elvitigala Mawatha,
Colombo – 08,
SRI LANKA.

Sri Lanka Standards are subject to periodical revision in order to accommodate the progress made by industry. Suggestions for improvement will be recorded and brought to the notice of the Committees to which the revisions are entrusted.

This standard does not purport to include all the necessary provisions of a contract.

© SLSI 2010

All right reserved. Unless otherwise specified, no part of this publication may be reproduced or utilized in any form or by any means, electronic or mechanical, including photocopying and microfilm, without permission in writing from the SLSI.

Sri Lanka Standard
SPECIFICATION FOR AC AND/OR DC- SUPPLIED ELECTRONIC BALLAST
FOR TUBULAR FLUORESCENT LAMPS
PART 1: SAFETY REQUIREMENTS

NATIONAL FOREWORD

This standard was approved by the Sectoral Committee on Electrical Appliances and Accessories and was authorized for adoption and publication as a Sri Lanka Standard by the Council of Sri Lanka Standards Institution on 2011-07-08.

SLS 1239 Part 1 and **SLS 1239 Part 2** supersede **SLS 1239: 2002** A.C. supplied electronic ballasts for tubular fluorescent lamps –Performance requirements.

SLS 1239 Specification for AC and/or DC- supplied electronic ballast for tubular fluorescent lamps, is published in two parts as follows:

- Part 1 Safety requirements
- Part 2 Performance requirements

This part of the standard is identical with **IEC 61347-2-3: 2011**, Edition 2.0 2011-05 Lamp control gear – Part 2-3: Particular requirements for a.c. and/or d.c. supplied electronic control gear for fluorescent lamps, published by the International Electrotechnical Commission (IEC).

For the purpose of deciding whether a particular requirement of this standard is complied with the final value, observed or calculated, expressing the results of a test or an analysis shall be rounded off in accordance with **SLS 102**. The number of significant places to be retained in the rounded off value shall be the same as that of the specified value in the standard.

Terminology and conventions

The text of the International Standard has been accepted as suitable for publication without deviation, as a Sri Lanka Standard. However, certain terminology and conventions are not identical with those used in Sri Lanka Standards; attention is therefore drawn to the following:

- a) Wherever the words “International Standard” appear referring to this standard they should be interpreted as “Sri Lanka Standard”.
- b) Wherever the page numbers are quoted they are page number of IEC standard.
- c) The comma has been used as a decimal marker. In the Sri Lanka Standards it is the current practices to use full point on the base line as a decimal marker.

CROSS REFERENCES

International Standards

Corresponding Sri Lanka Standards

IEC 60929 AC and /or DC-supplied electronic control gear for tubular fluorescent lamps –Performance requirements

SLS 1239 AC and/or DC- supplied electronic ballast for tubular fluorescent lamps- Part 2: Performance requirements

IEC 61347-1: Lamps control gear- Part 1: General and safety requirements

SLS IEC 61347-1: Lamps control gear- Part 1: General and safety requirements

NOTE : *Corresponding Sri Lanka Standards for other international standards listed under references in IEC 61347-2-3 are not available.*

INTERNATIONAL STANDARD

NORME INTERNATIONALE

**Lamp control gear –
Part 2-3: Particular requirements for a.c. and/or d.c. supplied electronic control
gear for fluorescent lamps**

**Appareillages de lampes –
Partie 2-3: Exigences particulières pour les appareillages électroniques
alimentés en courant alternatif et/ou en courant continu pour lampes
fluorescentes**



THIS PUBLICATION IS COPYRIGHT PROTECTED

Copyright © 2011 IEC, Geneva, Switzerland

All rights reserved. Unless otherwise specified, no part of this publication may be reproduced or utilized in any form or by any means, electronic or mechanical, including photocopying and microfilm, without permission in writing from either IEC or IEC's member National Committee in the country of the requester.

If you have any questions about IEC copyright or have an enquiry about obtaining additional rights to this publication, please contact the address below or your local IEC member National Committee for further information.

Droits de reproduction réservés. Sauf indication contraire, aucune partie de cette publication ne peut être reproduite ni utilisée sous quelque forme que ce soit et par aucun procédé, électronique ou mécanique, y compris la photocopie et les microfilms, sans l'accord écrit de la CEI ou du Comité national de la CEI du pays du demandeur.

Si vous avez des questions sur le copyright de la CEI ou si vous désirez obtenir des droits supplémentaires sur cette publication, utilisez les coordonnées ci-après ou contactez le Comité national de la CEI de votre pays de résidence.

IEC Central Office
3, rue de Varembe
CH-1211 Geneva 20
Switzerland
Email: inmail@iec.ch
Web: www.iec.ch

About the IEC

The International Electrotechnical Commission (IEC) is the leading global organization that prepares and publishes International Standards for all electrical, electronic and related technologies.

About IEC publications

The technical content of IEC publications is kept under constant review by the IEC. Please make sure that you have the latest edition, a corrigenda or an amendment might have been published.

- Catalogue of IEC publications: www.iec.ch/searchpub

The IEC on-line Catalogue enables you to search by a variety of criteria (reference number, text, technical committee,...). It also gives information on projects, withdrawn and replaced publications.

- IEC Just Published: www.iec.ch/online_news/justpub

Stay up to date on all new IEC publications. Just Published details twice a month all new publications released. Available on-line and also by email.

- Electropedia: www.electropedia.org

The world's leading online dictionary of electronic and electrical terms containing more than 20 000 terms and definitions in English and French, with equivalent terms in additional languages. Also known as the International Electrotechnical Vocabulary online.

- Customer Service Centre: www.iec.ch/webstore/custserv

If you wish to give us your feedback on this publication or need further assistance, please visit the Customer Service Centre FAQ or contact us:

Email: csc@iec.ch
Tel.: +41 22 919 02 11
Fax: +41 22 919 03 00

A propos de la CEI

La Commission Electrotechnique Internationale (CEI) est la première organisation mondiale qui élabore et publie des normes internationales pour tout ce qui a trait à l'électricité, à l'électronique et aux technologies apparentées.

A propos des publications CEI

Le contenu technique des publications de la CEI est constamment revu. Veuillez vous assurer que vous possédez l'édition la plus récente, un corrigendum ou amendement peut avoir été publié.

- Catalogue des publications de la CEI: www.iec.ch/searchpub/cur_fut-f.htm

Le Catalogue en-ligne de la CEI vous permet d'effectuer des recherches en utilisant différents critères (numéro de référence, texte, comité d'études,...). Il donne aussi des informations sur les projets et les publications retirées ou remplacées.

- Just Published CEI: www.iec.ch/online_news/justpub

Restez informé sur les nouvelles publications de la CEI. Just Published détaille deux fois par mois les nouvelles publications parues. Disponible en-ligne et aussi par email.

- Electropedia: www.electropedia.org

Le premier dictionnaire en ligne au monde de termes électroniques et électriques. Il contient plus de 20 000 termes et définitions en anglais et en français, ainsi que les termes équivalents dans les langues additionnelles. Egalement appelé Vocabulaire Electrotechnique International en ligne.

- Service Clients: www.iec.ch/webstore/custserv/custserv_entry-f.htm

Si vous désirez nous donner des commentaires sur cette publication ou si vous avez des questions, visitez le FAQ du Service clients ou contactez-nous:

Email: csc@iec.ch
Tél.: +41 22 919 02 11
Fax: +41 22 919 03 00



INTERNATIONAL STANDARD

NORME INTERNATIONALE

Lamp control gear –

Part 2-3: Particular requirements for a.c. and/or d.c. supplied electronic control gear for fluorescent lamps

Appareillages de lampes –

Partie 2-3: Exigences particulières pour les appareillages électroniques alimentés en courant alternatif et/ou en courant continu pour lampes fluorescentes

INTERNATIONAL
ELECTROTECHNICAL
COMMISSION

COMMISSION
ELECTROTECHNIQUE
INTERNATIONALE

PRICE CODE
CODE PRIX



ICS 29.140.99

ISBN 978-2-88912-498-5

CONTENTS

FOREWORD.....	4
INTRODUCTION.....	6
1 Scope.....	7
2 Normative references	7
3 Terms and definitions	8
4 General requirements	8
5 General notes on tests	9
6 Classification.....	9
7 Marking	9
8 Protection against accidental contact with live parts	10
9 Terminals	10
10 Provisions for earthing.....	10
11 Moisture resistance and insulation.....	10
12 Electric strength	10
13 Thermal endurance test for windings	10
14 Fault conditions	10
15 Protection of associated components	10
16 Abnormal conditions	11
17 Behaviour of the control gear at end of lamp life.....	12
18 Construction.....	19
19 Creepage distances and clearances	19
20 Screws, current-carrying parts and connections.....	19
21 Resistance to heat, fire and tracking.....	19
22 Resistance to corrosion	19
Annex A (normative) Test to establish whether a conductive part is a live part which may cause an electric shock	24
Annex B (normative) Particular requirements for thermally protected lamp control gear	25
Annex C (normative) Particular requirements for electronic lamp control gear with means of protection against overheating.....	26
Annex D (normative) Requirements for carrying out the heating tests of thermally protected lamp control gear	27
Annex E (normative) Use of constant S other than 4 500 in t_w tests.....	28
Annex F (normative) Draught-proof enclosure.....	29
Annex G (normative) Explanation of the derivation of the values of pulse voltages	30
Annex H (normative) Tests	31
Annex I (normative) Measurement of high-frequency leakage current	32
Annex J (normative) Particular additional safety requirements for a.c., a.c./d.c. or d.c. supplied electronic control gear for emergency lighting	37
Annex K (informative) Components used in the asymmetric pulse test circuit (see Figure 1).....	41
Annex L (normative) Information for control gear design (from Annex E of IEC 61195).....	42
Bibliography.....	43

Figure 1 – Asymmetric pulse test circuit.....	14
Figure 2 – Asymmetric power detection circuit	16
Figure 3 – Open filament test circuits.....	19
Figure 4 – Circuit for testing rectifying effect.....	20
Figure 5 – Nomographs for the capacitive leakage current limits of HF-operated fluorescent lamps	23
Figure I.1 – Leakage current test arrangement for various fluorescent lamps	36
Table 1 – Relation between r.m.s. working voltage and maximum peak voltage	11
Table J.1 – Pulse voltages	40
Table K.1 – Material specification	41
Table K.2 – Transformer specification.....	41

INTERNATIONAL ELECTROTECHNICAL COMMISSION

LAMP CONTROL GEAR –**Part 2-3: Particular requirements for a.c. and/or d.c.
supplied electronic control gear for fluorescent lamps**

FOREWORD

- 1) The International Electrotechnical Commission (IEC) is a worldwide organization for standardization comprising all national electrotechnical committees (IEC National Committees). The object of IEC is to promote international co-operation on all questions concerning standardization in the electrical and electronic fields. To this end and in addition to other activities, IEC publishes International Standards, Technical Specifications, Technical Reports, Publicly Available Specifications (PAS) and Guides (hereafter referred to as "IEC Publication(s)"). Their preparation is entrusted to technical committees; any IEC National Committee interested in the subject dealt with may participate in this preparatory work. International, governmental and non-governmental organizations liaising with the IEC also participate in this preparation. IEC collaborates closely with the International Organization for Standardization (ISO) in accordance with conditions determined by agreement between the two organizations.
- 2) The formal decisions or agreements of IEC on technical matters express, as nearly as possible, an international consensus of opinion on the relevant subjects since each technical committee has representation from all interested IEC National Committees.
- 3) IEC Publications have the form of recommendations for international use and are accepted by IEC National Committees in that sense. While all reasonable efforts are made to ensure that the technical content of IEC Publications is accurate, IEC cannot be held responsible for the way in which they are used or for any misinterpretation by any end user.
- 4) In order to promote international uniformity, IEC National Committees undertake to apply IEC Publications transparently to the maximum extent possible in their national and regional publications. Any divergence between any IEC Publication and the corresponding national or regional publication shall be clearly indicated in the latter.
- 5) IEC itself does not provide any attestation of conformity. Independent certification bodies provide conformity assessment services and, in some areas, access to IEC marks of conformity. IEC is not responsible for any services carried out by independent certification bodies.
- 6) All users should ensure that they have the latest edition of this publication.
- 7) No liability shall attach to IEC or its directors, employees, servants or agents including individual experts and members of its technical committees and IEC National Committees for any personal injury, property damage or other damage of any nature whatsoever, whether direct or indirect, or for costs (including legal fees) and expenses arising out of the publication, use of, or reliance upon, this IEC Publication or any other IEC Publications.
- 8) Attention is drawn to the Normative references cited in this publication. Use of the referenced publications is indispensable for the correct application of this publication.
- 9) Attention is drawn to the possibility that some of the elements of this IEC Publication may be the subject of patent rights. IEC shall not be held responsible for identifying any or all such patent rights.

International Standard IEC 61347-2-3 has been prepared by subcommittee 34C: Auxiliaries for lamps, of IEC technical committee 34: Lamps and related equipment.

This standard shall be used in conjunction with IEC 61347-1 (2007) and its Amendment 1 (2010).

This second edition cancels and replaces the first edition published in 2000, its Amendment 1 (2004) and its Amendment 2 (2006)), IEC 61347-2-4 published in 2000, IEC 61347-2-5 published in 2000 and IEC 61347-2-6 published in 2000. This second edition constitutes a technical revision.

The significant revisions with respect to the first edition are:

- rectifying test conditions when dimming;
- construction requirements;
- measurement circuits and limits for HF leakage currents;
- modification of the structure to become a standard exclusively for a.c. and d.c. centrally supplied electronic control gear for general lighting and Annex J cover centrally-supplied emergency control gear.

The text of this standard is based on the following documents:

FDIS	Report on voting
34C/955/FDIS	34C/968/RVD

Full information on the voting for the approval of this standard can be found in the report on voting indicated in the above table.

This publication has been drafted in accordance with the ISO/IEC Directives, Part 2.

This part 2 supplements or modifies the corresponding clauses in IEC 61347-1 so as to convert that publication into the IEC standard: Particular requirements for a.c. and/or d.c. centrally supplied electronic control gear for fluorescent lamps.

NOTE In this standard, the following print types are used:

- Requirements proper: in roman type.
- *Test specifications: in italic type.*
- Explanatory matter: in smaller roman type.

A list of all parts of the IEC 61347 series, published under the general title: *Lamp control gear*, can be found on the IEC website.

The committee has decided that the contents of this publication will remain unchanged until the stability date indicated on the IEC web site under "<http://webstore.iec.ch>" in the data related to the specific publication. At this date, the publication will be

- reconfirmed,
- withdrawn,
- replaced by a revised edition, or
- amended.

INTRODUCTION

This second edition of IEC 61347-2-3, published in conjunction with IEC 61347-1, represents an review of the first edition of IEC 61347-2-3. The formatting into separately published parts provides for ease of future amendments and revisions. Additional requirements will be added as and when a need for them is recognized.

This standard, and the parts which make up IEC 61347-2, in referring to any of the clauses of IEC 61347-1, specify the extent to which such a clause is applicable and the order in which the tests are to be performed; they also include additional requirements, as necessary. All parts which make up IEC 61347-2 are intended to be self-contained and, therefore, do not include references to each other. However, for the case of emergency lighting lamp control gear, some cross-referencing has been necessary.

Where the requirements of any of the clauses of IEC 61347-1 are referred to in this standard by the phrase "The requirements of clause n of IEC 61347-1 apply", this phrase is interpreted as meaning that all requirements of the clause in question of part 1 apply, except any which are clearly inapplicable to the specific type of lamp control gear covered by this particular part of IEC 61347-2.

LAMP CONTROL GEAR –

Part 2-3: Particular requirements for a.c. and/or d.c. supplied electronic control gear for fluorescent lamps

1 Scope

This part of IEC 61347 specifies particular safety requirements for electronic control gear for use on a.c. and d.c. supplies up to 1 000 V at 50 Hz or 60 Hz with operating frequencies deviating from the supply frequency, associated with fluorescent lamps as specified in IEC 60081 and IEC 60901, and other fluorescent lamps for high-frequency operation.

Performance requirements are the subject of IEC 60929.

Particular requirements for electronic control gear with means protection against overheating are given in Annex C.

For emergency lighting operation, particular requirements for control gear operated from a central supply are given in Annex J. Performance requirements appropriate to the safe operation of emergency lighting are also contained in Annex J.

Requirements for emergency lighting control gear operating from non-centralised power supplies are given in IEC 61347-2-7.

NOTE Performance requirements detailed by Annex J are those considered to be safety-related with respect to reliable emergency operation.

2 Normative references

For the purposes of this document, the normative references given in Clause 2 of IEC 61347-1 which are mentioned in this standard apply, together with the following normative references.

IEC 60929: 2011, *AC and/or DC-supplied electronic control gear for tubular fluorescent lamps – Performance requirements*

IEC 61347-1:2007, *Lamp control gear – Part 1: General and safety requirements*
Amendment 1(2010)

IEC 61347-2-7, ___ *Lamp control gear – Part 2-7: Particular requirements for battery supplied electronic control gear for emergency lighting (self-contained)*¹

IEC 61547, *Equipment for general lighting purposes – EMC immunity requirements*

¹ To be published

3 Terms and definitions

For the purposes of this document, the terms and definitions of Clause 3 of IEC 61347-1 apply, together with the following.

3.1

a.c. supplied electronic control gear

mains-supplied a.c. to a.c. inverter including stabilizing elements for starting and operating one or more fluorescent lamps, generally at high frequency

3.2

maximum value of lamp power (of a controllable control gear)

lamp power (light output) which complies with 8.1 of IEC 60929, unless otherwise declared by the manufacturer or responsible vendor

3.3

maximum allowed peak voltage

highest permitted peak voltage across any insulation under open-circuit condition and any normal and abnormal operating conditions

The maximum peak voltage is related to the declared r.m.s. working voltage; see Table 1.

3.4

minimum value of lamp power (of a controllable control gear)

lowest percentage of the lamp power defined in 3.2 declared by the manufacturer or responsible vendor

3.5

a.c./d.c. supplied electronic control gear for maintained emergency lighting

mains/battery-supplied a.c./d.c. to a.c. inverter including stabilizing elements for starting and operating one or more fluorescent lamps, generally at high frequency for emergency lighting

3.6

cathode dummy resistor

cathode substitution resistor as specified on the relevant lamp data sheet of IEC 60081 or IEC 60901 or as declared by the relevant lamp manufacturer or by the responsible vendor

3.7

d.c. supplied electronic control gear

d.c. supplied electronic control gear or inverter includes stabilisation elements for starting and operating one or more tubular fluorescent lamps, generally at high frequency

4 General requirements

The requirements of Clause 4 of IEC 61347-1 apply, together with the following additional requirement:

AC/d.c. electronic control gear for emergency lighting shall comply with the requirements of Annex J.

5 General notes on tests

The requirements of Clause 5 of 61347-1 apply together with the following additional requirement:

The following number of specimens shall be submitted for testing:

- one unit for the tests of Clause 6 to 12 and 15 to 22;
- one unit for the test of Clause 14 (additional units or components, where necessary, may be required in consultation with the manufacturer).

Tests to meet the safety requirements for a.c./d.c. supplied electronic control gear for emergency lighting are made under the conditions specified in Annex J.

6 Classification

The requirements of Clause 6 of IEC 61347-1 apply.

7 Marking

Control gear which forms an integral part of the luminaire need not be marked.

7.1 Mandatory markings

In accordance with the requirements of 7.2 of IEC 61347-1, control gear, other than integral control gear, shall be clearly and durably marked with the following mandatory markings:

- items a), b), c), d), e), k) and l) of 7.1 of IEC 61347-1, together with
- the symbol for earthing, as applicable;
- for controllable control gear, the control terminals shall be identified;
- a declaration of the maximum working voltage (r.m.s.) according to 12.2 between
 - output terminals;
 - any output terminal and earth.

Marking for each of these two values shall be in steps of 10 V when the working voltage is equal to, or less than, 500 V, and in steps of 50 V when the working voltage is higher than 500 V. The marking of maximum working voltage is referenced in two situations, the maximum between output terminals and the maximum between any output terminal and earth. It is acceptable for only the higher of these two voltages to be marked.

Marking shall be U-OUT=...V.

7.2 Information to be provided, if applicable

In addition to the above mandatory markings, the following information, if applicable, shall be given either on the control gear, or be made available in the manufacturer's catalogue or similar:

- items h), i), and j) given in 7.1 of IEC 61347-1;
- information regarding voltage polarity reversal protection for d.c. supplied control gear only.

8 Protection against accidental contact with live parts

The requirements of Clause 10 of IEC 61347-1 apply.

9 Terminals

The requirements of Clause 8 of IEC 61347-1 apply.

10 Provisions for earthing

The requirements of Clause 9 of IEC 61347-1 apply.

11 Moisture resistance and insulation

The requirements of Clause 11 of IEC 61347-1 apply together with the following additional requirements:

The leakage current that may occur from contact with fluorescent lamps operated at high frequency from a.c. supplied electronic control gear shall not exceed the values in Figure 5 when measured in accordance with Annex I. The values are in r.m.s. values.

The limits of leakage current values for frequencies between the values shown in Figure 5 should be obtained by calculation according to the formula in the figure (under consideration).

NOTE Limits of leakage current values for frequencies above 50 kHz are under consideration.

Compliance with these requirements is checked in accordance with Annex I.

12 Electric strength

The requirements of Clause 12 of IEC 61347-1 apply.

13 Thermal endurance test for windings

The requirements of Clause 13 of IEC 61347-1 do not apply.

14 Fault conditions

The requirements of Clause 14 of IEC 61347-1 apply.

An additional fault condition to be applied to d.c. supplied control gear is the supply voltage polarity shall be reversed.

15 Protection of associated components

15.1 Maximum peak voltage under normal operation conditions

Under conditions of normal operation, verified with dummy cathode resistors inserted and conditions of abnormal operation, as specified in Clause 16, the voltage at the output terminals shall at no time exceed the maximum permitted peak value specified in Table 1.

Table 1 – Relation between r.m.s. working voltage and maximum peak voltage

Voltage at output terminals	
RMS working voltage V	Maximum permitted peak voltage V
250	2 200
500	2 900
750	3 100
1 000	3 200
NOTE Linear interpolation between the given voltage steps is allowed.	

15.2 Maximum working voltage under normal and abnormal operating conditions

Under normal operating conditions and abnormal operating conditions as specified in Clause 16, except for the rectifying effect, and from 5 s after the switch on or beginning of the starting process, the voltage at the output terminals shall not exceed the maximum working voltage for which the control gear is declared.

15.3 Maximum working voltage and rectifying effect

In the case of a rectifying effect, i.e. abnormal operating condition according to 16.1 d), the r.m.s. voltage at the output terminal shall not exceed the maximum permitted value for which the control gear is designed for a period longer than 30 s after switch-on, or beginning of the starting process.

For control gear which makes more than one attempt to start a failed lamp, the combined duration of voltages above the maximum working voltage for which the ballast is declared shall not exceed 30 s.

Circuit for testing the rectifying effect and the information regarding the recovery time t_{rr} of the diode are given Figure 4 (4a, 4b and 4c).

15.4 Output voltage and abnormal conditions

For the tests of 15.1 and 15.2, the output voltages measured shall be those between any output terminal and earth. Additionally, voltages that appear between output terminals shall be measured in cases where the voltage is present across insulation barriers within associated components.

15.5 Isolation of input terminals of controllable electronic control gear

For controllable electronic control gear, the control input shall be isolated from the mains circuit by insulation at least equal to basic insulation.

NOTE This requirement does not apply to those control gear where control signals are injected via the supply terminals or where the control signals are completely isolated from the ballast by being transmitted remotely from infra-red or radio wave transmitters.

If SELV is to be used, then double or reinforced insulation is required.

16 Abnormal conditions

16.1 Abnormal conditions for a.c. and d.c. control gears

The control gear shall not impair safety when operated under abnormal conditions at any voltage between 90 % and 110 % of the rated supply voltage.

Compliance is checked by the following test.

Each of the following conditions shall be applied with the control gear operating according to the manufacturer's instructions (including a heat sink, if specified) for 1 h:

- a) the lamp or one of the lamps is not inserted;*
- b) the lamp does not start because one of the cathodes is broken;*
- c) the lamp does not start although the cathode circuits are intact (de-activated lamp);*
- d) the lamp operates, but one of the cathodes is de-activated or broken (rectifying effect);*
- e) short circuit of the starter switch, if any.*

For the test simulating operation with a de-activated lamp, a resistor is connected in place of each lamp cathode. The resistor value is derived from the value of the nominal running current of the lamp prescribed in the relevant lamp data sheet of IEC 60081 and IEC 60901 and substituted in the following equation:

$$R = \frac{11,0}{2,1 \times I_n} \Omega$$

where

I_n is the rated lamp current of the lamp.

For lamps not covered by IEC 60081 and IEC 60901, the values declared by the lamp manufacturer shall be used.

When testing electronic ballasts for the rectifying effect, the circuit shown in Figure 1 is used. The anode of the rectifier is connected to the midpoints of appropriate equivalent resistors; the cathode of the rectifier is connected to the short circuited lamp electrode. The direction of the rectifying effect is chosen so as to give the most unfavourable conditions. If necessary, the lamp is started using a suitable device.

During and at the end of the tests specified under items a) to e), the control gear shall show no defect impairing safety nor shall any smoke be produced.

16.2 Additional abnormal conditions for d.c. supplied electronic control gear

If the d.c. supplied electronic control gear declared by the manufacturer as a protected control gear against the reversal polarity of the supply voltage, then the following test is applied:

The d.c. supplied electronic control gear shall be connected for 1 h with the reversal supply voltage at the maximum value of the rated voltage with the maximum lamp power declared by the manufacturer.

During and at the end of the test the electronic control gear shall operate the lamp(s) normally without any defects.

17 Behaviour of the control gear at end of lamp life

17.1 End of lamp life effects

At the end of lamp life, the control gear shall behave in such a way that no overheating of lamp cap(s) occurs at any voltage between 90 % and 110 % of the rated supply voltage.

For the test simulating end of lamp life effects, three tests are described:

- a) asymmetric pulse test (described in 17.2);
- b) asymmetric power dissipation test (described in 17.3);
- c) open filament test (described in 17.4).

Any of the three tests may be used to qualify electronic control gear. The control gear manufacturer shall determine which of the three tests will be used to test a given control gear based on the design of that particular control gear circuit. The chosen test method shall be indicated in the control gear manufacturer's literature.

NOTE 1 Checking control gear against their capability to cope with the partial rectifying effect is recommended by IEC 61195, Annex E, and IEC 61199, Annex H.

NOTE 2 In Japan, only the requirements of 17.1 b) are applied for electronic control gear.

Lamps used in the ballast test circuits shall be new lamps seasoned for 100 h.

17.2 Asymmetric pulse test

The ballast shall have adequate protection to prevent lamp cap overheating at the end of the lamp life cycle. Compliance is checked by the following test.

The following values of maximum cathode power P_{\max} apply:

- for 13 mm (T4) lamps, $P_{\max} = 5,0 \text{ W}$;
- for 16 mm (T5) lamps, $P_{\max} = 7,5 \text{ W}$.

(Other diameters are under study.)

Test procedure:

Refer to the schematic diagram in Figure 1.

If only one connection per electrode is available at the control gear and/or lamp, T1 shall be removed and then the control gear shall be connected to J2 and the lamp to J4. The control gear manufacturer should be asked which of the output terminals has to be connected to J4 and, in case two output terminals per electrode exist, whether they can be short-circuited or be bridged with a resistor.

- (1) Close switches S1 and S4, and set switch S2 to position A.
- (2) Turn on the control gear under test and allow lamp(s) to warm up for 5 min.
- (3) Close S3, open S1, and wait for 15 s. Open S4 and wait for 15 s.
- (4) Measure the sum of the average power dissipated in the power resistors, R1A to R1C and R2A and R2B, and the Zener diodes, D5 to D8.

NOTE The power should be measured as the average value of the product of the voltage between terminals J5 and J6 times the current flowing from J8 to J7. The voltage should be measured with a differential voltage probe, and the current should be measured with a d.c. current probe. A digital oscilloscope can be used for the multiplication and averaging functions. If the control gear operates in a cycling mode, the averaging interval should be set to cover an integer number of cycles. (Each cycle is typically greater than 1 s.) The sampling rate and number of samples included in the calculations should be sufficient to avoid aliasing errors.

The power dissipation shall be below P_{\max} .

If the power dissipation is greater than P_{\max} , the control gear has failed and the test is discontinued.

- (5) Close S1 and S4.
- (6) Set S2 to position B.

- (7) Repeat steps (2), (3) and (4).
The control gear shall pass both position "A" and position "B" tests.
- (8) For multi-lamp control gear, repeat steps (1) to (7) for each lamp position.
A multi-lamp control gear shall pass the tests for each lamp position.
- (9) For control gear that operate multiple lamp types (e.g. 26 W, 32 W, 42 W), each lamp type specified shall be tested. Repeat steps (1) to (8) for each lamp type.

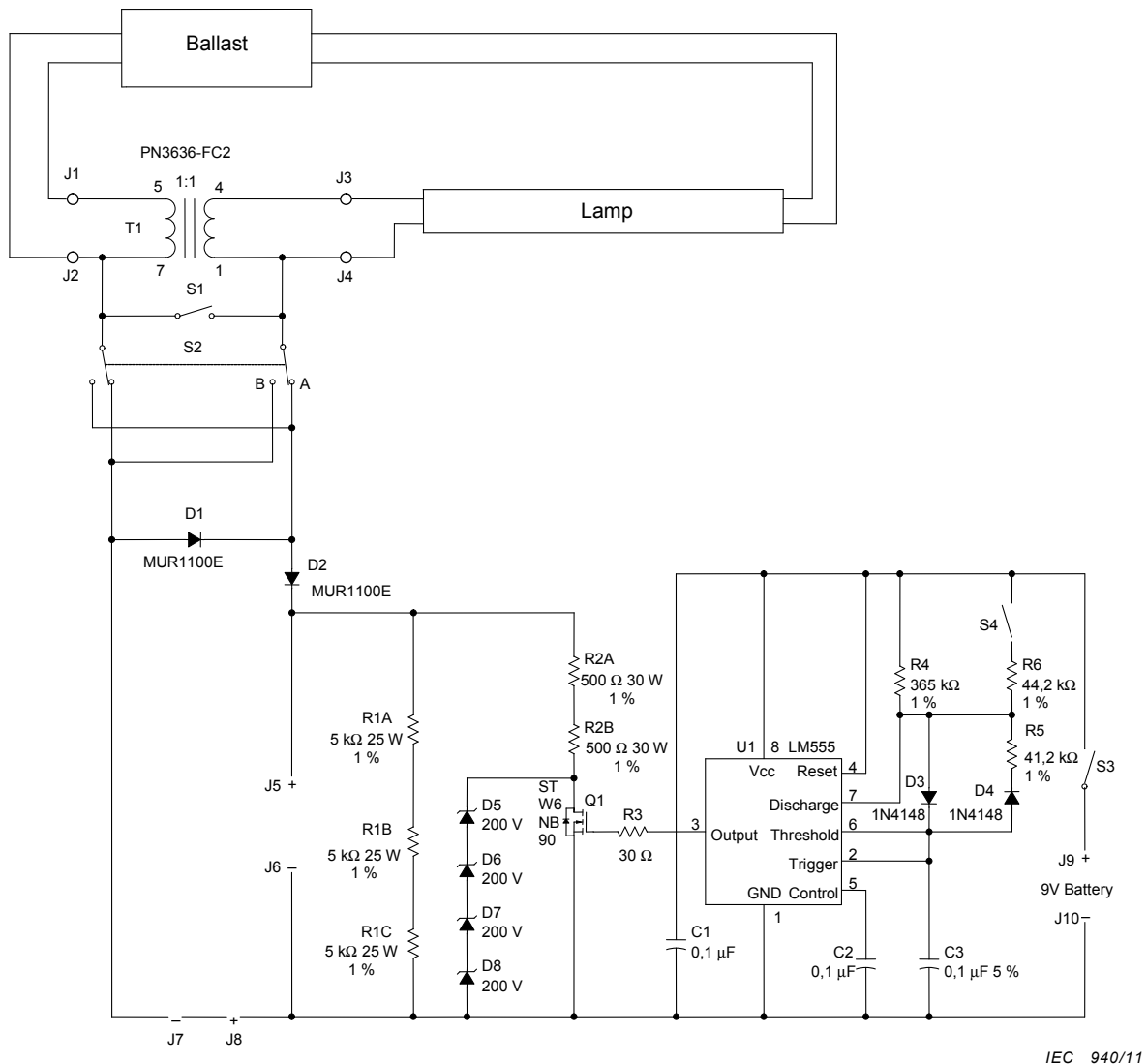

IEC 940/11

Figure 1 – Asymmetric pulse test circuit

NOTE FET Q1 should be on for 3 ms and off for 3 ms when S4 is closed, and on for 27 ms and off for 3 ms when S4 is open.

A list of material and transformer specifications is given in Annex K. Any other transformer components with the same functionality are permitted.

17.3 Asymmetric power test

The control gear shall have adequate protection to prevent lamp cap overheating at the end of the lamp life cycle. Compliance is checked by the following test.

The following values of maximum cathode power P_{\max} apply:

- for 13 mm (T4) lamps, $P_{\max} = 5,0 \text{ W}$;
- for 16 mm (T5) lamps, $P_{\max} = 7,5 \text{ W}$.

(Other diameters are under study.)

Test procedure:

Refer to the schematic diagram in Figure 2.

- (1) Set switch S1 to position A.
- (2) Set resistance of resistor R1 to 0 (zero) Ω .
- (3) Start lamp(s) by turning on power to control gear under test and allow lamp(s) to warm up for 5 min.
- (4) Increase the resistance of R1 rapidly, (within 15 s) until the power dissipated by resistor R1 equals the test wattage value of 10 W for a T4 lamp or 15 W for a T5 lamp. If the control gear limits the power in R1 to a value less than the test wattage, set R1 at the value which produces the maximum wattage. If the control gear switches off before reaching the test wattage, continue with (5). If the control gear does not switch off and limits the power in R1 to a value less than the test wattage, set R1 at the value which produces the maximum wattage.
- (5) If the test wattage value was reached in step (4), wait for an additional 15 s. If the test wattage value was not reached in step (4), wait for an additional 30 s. Measure the power in R1.

The power dissipation in resistor R1 shall be below or equal to P_{\max} . If the power dissipation in resistor R1 is greater than P_{\max} , The control gear has failed and the test is discontinued.

- (6) Turn off power to control gear. Set switch S1 to position B.
- (7) Repeat test procedure steps (3) to (5) above.
The control gear shall pass both position "A" and position "B" tests.
- (8) For multi-lamp control gear, repeat test procedure steps (1) to (7) for each lamp position.

A multi-lamp control gear shall pass the tests for each lamp position.

- (9) For control gear that operate multiple lamp types (e.g. 26 W, 32 W, 42 W) each lamp type specified shall be tested. Repeat steps (1) to (8) for each lamp type.

17.4.3 Test procedure A

Refer to schematic diagram in Figure 3a.

- (1) Set S to position 1.
- (2) Turn on the ballast under test and allow lamp(s) to warm up for 5 min.
- (3) Set S to position 2 and wait for 30 s.
- (4) Measure the r.m.s. current value of I_{lamp} with the current probe near to the lamp end. If I_{lamp} is pulsing, the r.m.s. value shall be computed over one complete pulse cycle including the off time.

The lamp discharge current I_{lamp} shall not be greater than I_{max} .

If the lamp discharge current is greater than I_{max} , the control gear has failed and the test is discontinued.

Refer to Figure 3b.

- (5) Set S to position 1.
- (6) Turn on the control gear under test and allow lamp(s) to warm up for 5 min.
- (7) Set S to position 2 and wait for 30 s.
- (8) Measure the r.m.s. current value of I_{lamp} with the current probe near to the lamp end. If I_{lamp} is pulsing, the r.m.s. value shall be computed over one complete pulse cycle including the off time.

The lamp discharge current I_{lamp} shall not be greater than I_{max} .

- (9) For multi-lamp control gear, repeat test procedure steps (1) to (8) for each lamp position.

A multi-lamp control gear shall pass the tests for each lamp position to pass the end-of-lamp-life test.

- (10) For control gear that operate multiple lamp types (e.g. 26 W, 32 W, 42 W), each lamp type specified shall be tested. Repeat steps (1) to (9) for each lamp type.

17.4.4 Test procedure B

Connect the lamp as shown in Figures 3a and 3b with the measurement arrangement according to Figure 3c. If the control gear has an isolation transformer, connect the 1 MΩ resistor to the corresponding terminal defined in 17.4.2.

- (1) Set S to position 1.
- (2) Turn on the control gear under test and allow lamp(s) to warm up for 5 min.
- (3) Set S to position 2 wait for 30 s.
Measure the r.m.s. voltage value with the differential probe placed as indicated in Figure 5c. If the voltage is pulsing, the r.m.s. value shall be computed over one complete pulse cycle including the off time.
- (4) The voltage shall not be greater than 25 % of the rated lamp voltage. If the voltage is greater than 25 %, discontinue the test.

Refer to Figure 3b.

- (5) Repeat test procedure steps (1) to (4) above.
- (6) For multi-lamp control gear, repeat test procedure steps (1) to (5) for each lamp position.

A multi-lamp control gear shall pass the test for each lamp position to pass the end-of-lamp life test.

- (7) For control gear which operate multiple lamp types (e.g. 26 W, 32 W, 42 W), each lamp type specified shall be tested.

Repeat steps (1) to (6) for each lamp type. A multiple lamp control gear shall pass the test for each lamp type.

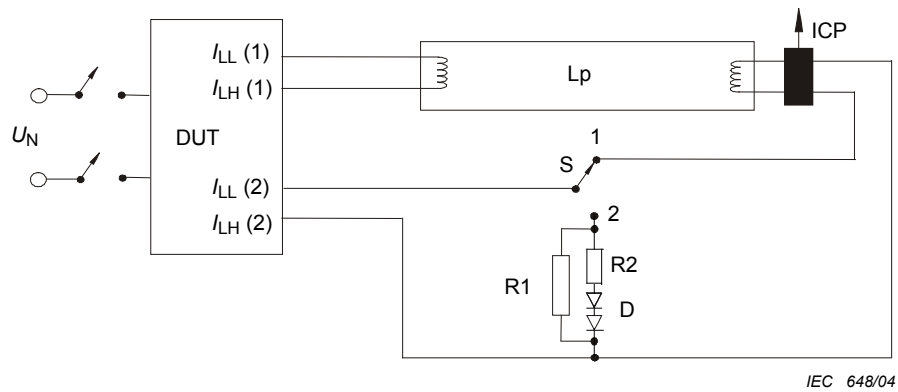

Figure 3a – Open filament test circuit; electrode (1) check

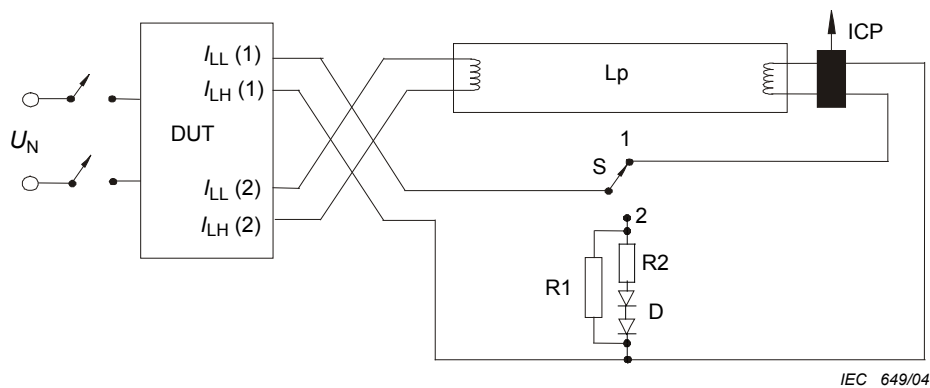
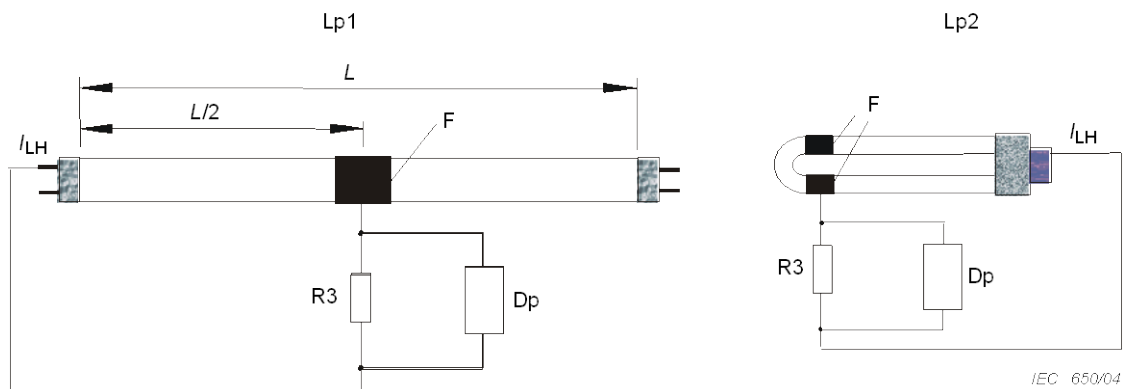

Figure 3b – Open filament test circuit; electrode (2) check



NOTE Use terminal $I_{LH}(2)$ of Figure 3a or $I_{LH}(1)$ of Figure 3b.

Figure 3c – Detection of lamp current

Key to Figures 3a, 3b and 3c

Lp lamp

Lp1 straight lamp; copper foil width 4 cm

Lp2 bended lamp (single capped and circular); copper foil width: twice 2 cm; both foils connected together

U_N supply

F copper foil, width 4 cm and 2 cm × 2 cm

ICP I_{lamp} current probe

R1 = 10 kΩ

R2 = 22 Ω, 7 W

R3 = 1 MΩ

D fast diodes

DUT device (control gear) under test

Dp differential probe < 10 pF

L lamp length

Figure 3 – Open filament test circuits

18 Construction

The requirements of Clause 15 of IEC 61347-1 apply.

19 Creepage distances and clearances

The requirements of Clause 16 of IEC 61347-1 apply.

20 Screws, current-carrying parts and connections

The requirements of Clause 17 of IEC 61347-1 apply.

21 Resistance to heat, fire and tracking

The requirements of Clause 18 of IEC 61347-1 apply.

22 Resistance to corrosion

The requirements of Clause 19 of IEC 61347-1 apply.

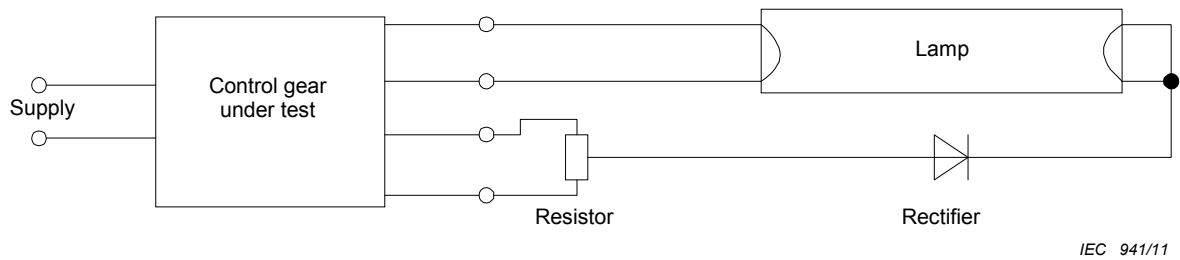

Figure 4a – Testing the first direction of the rectifying effect

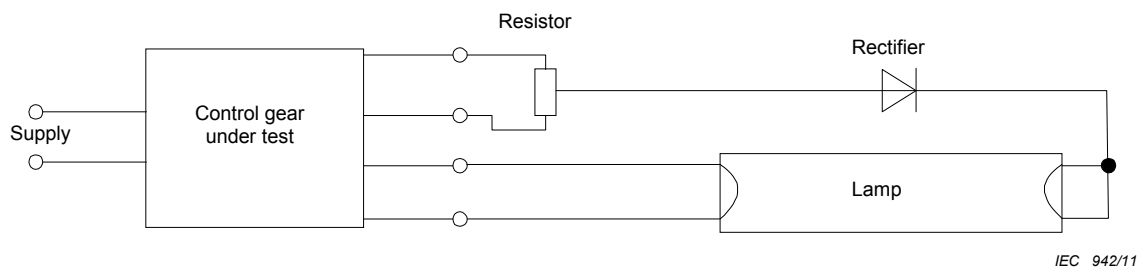
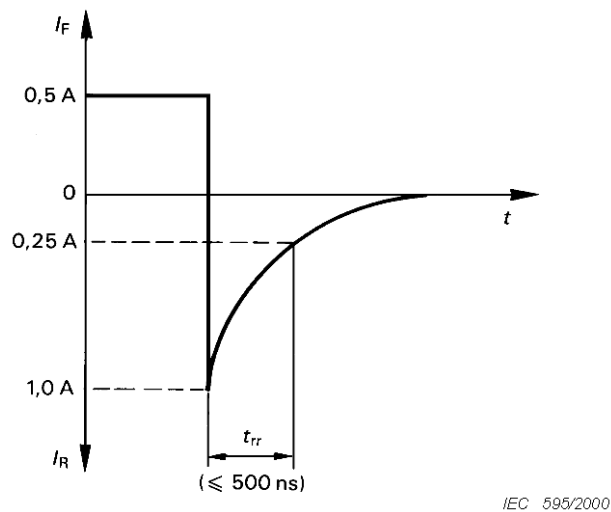

Figure 4b – Testing the opposite direction of the rectifying effect

Figure 4c – Recovery time t_{rr} of the diode**Key to figures 4a, 4b and 4c**

The rectifier characteristics shall be:

Peak inverse voltage	U_{RRM}	\geq	3 000 V
Reverse leakage current	I_R	\leq	10 μ A
Forward current	I_F	\geq	three times nominal lamp running current
Reverse recovery time (maximum frequency: 150 kHz)	t_{rr}	\leq	500 ns (measured with $I_F = 0,5$ A and $I_R = 1$ A to $I_R = 0,25$ A)

NOTE The following types of diodes (three diodes in series) are recommended as a suitable rectifier: RGP 30 M, BYM 96 E, BYV 16.

Figure 4 – Circuit for testing rectifying effect

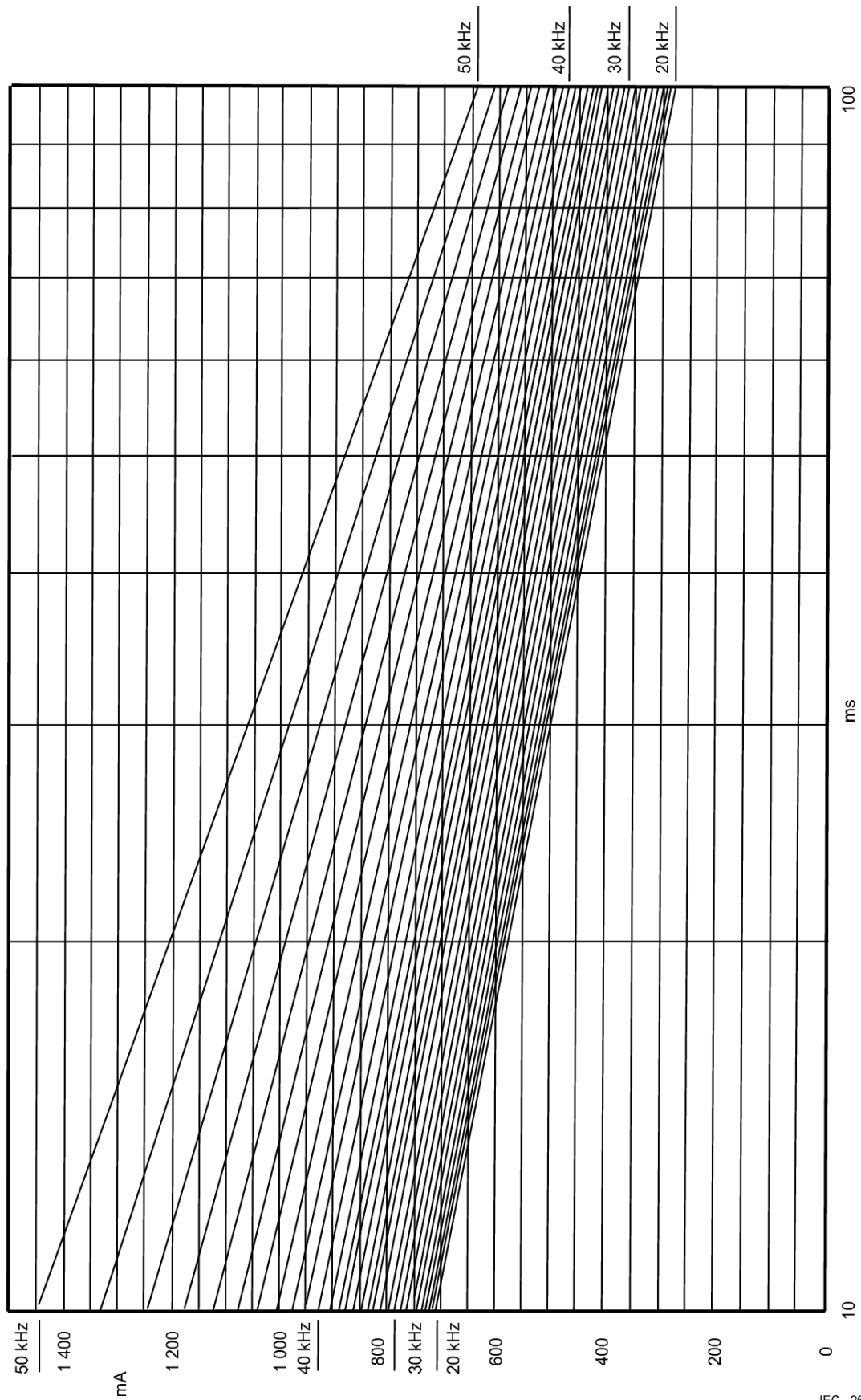

IEC 2624/05

Figure 5a – Limits for capacitive leakage current (in mA_{r.m.s.}) of HF-operated fluorescent lamps – Range 10 ms to 100 ms

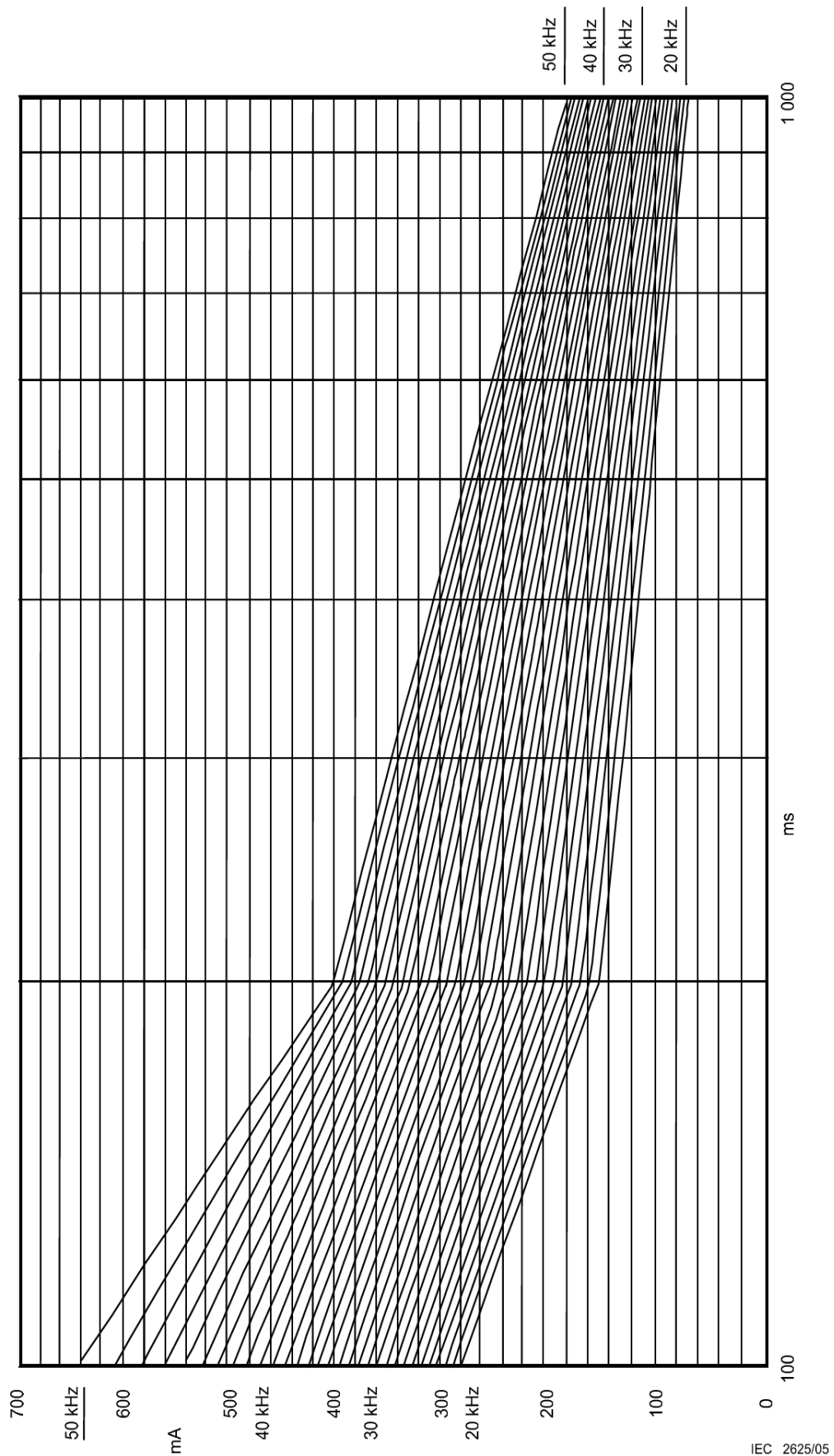

Figure 5b – Limits for capacitive leakage current (in mA_{r.m.s.}) of HF-operated fluorescent lamps – Range 100 ms to 1 000 ms

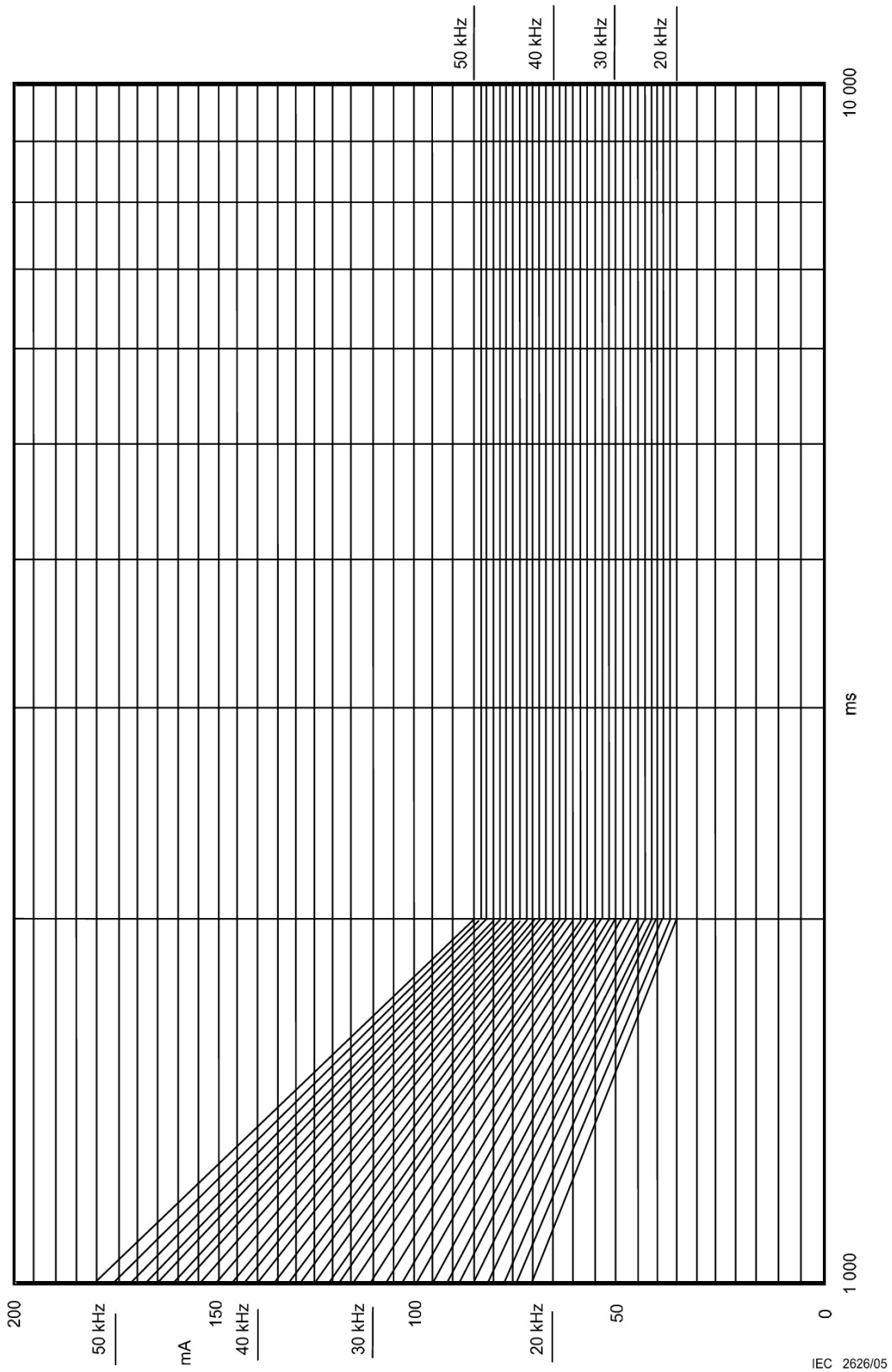

Figure 5c – Limits for capacitive leakage current (in mA_{r.m.s.}) of HF-operated fluorescent lamps – Range 1 000 ms to 10 000 ms

Figure 5 – Nomographs for the capacitive leakage current limits of HF-operated fluorescent lamps

Annex A
(normative)

**Test to establish whether a conductive part
is a live part which may cause an electric shock**

The requirements of Annex A of IEC 61347-1 apply.

Annex B
(normative)

**Particular requirements for thermally protected
lamp control gear**

The requirements of Annex B of IEC 61347-1 are not applicable.

Annex C
(normative)

**Particular requirements for electronic lamp control gear
with means of protection against overheating**

The requirements of Annex C of IEC 61347-1 apply.

Annex D
(normative)

**Requirements for carrying out the heating tests
of thermally protected lamp control gear**

The requirements of Annex D of IEC 61347-1 apply.

Annex E
(normative)

Use of constant S other than 4 500 in t_w tests

The requirements of Annex E of IEC 61347-1 are not applicable.

Annex F
(normative)

Draught-proof enclosure

The requirements of Annex F of IEC 61347-1 are not applicable.

Annex G
(normative)

Explanation of the derivation of the values of pulse voltages

The requirements of Annex G of IEC 61347-1 are not applicable.

Annex H
(normative)

Tests

The requirements of Annex H of IEC 61347-1 apply.

Annex I (normative)

Measurement of high-frequency leakage current

Electronic control gears are tested for capacitive high-frequency leakage current, as follows.

The ballast is tested in the circuit shown in Figure I.1 with two normal lamps, each being connected to the circuit at only one end ("crossed pair of lamps"). This method would also provide the worst-case leakage to earth.

The glass tube of one of the two lamps, whichever gives the worst value, is wrapped with a 75 mm wide metal foil, together with a non-inductive 2 000 Ω resistor and a measuring device suitable for the test circuit.

The test shall be conducted with the lamps supported on two 75 mm high wooden blocks and placed on a wooden table, such that no external influence from metallic surfaces is caused.

The leakage current (i.e. the high-frequency current flowing from the metal foil through the 2 000 $\Omega \pm 50 \Omega$ resistor to earth) is measured under the following simulated operating conditions.

- Two normal lamps, each being inserted at only one end into a pair of holders, with the supply voltage switched on.
- In order to take care of the most adverse condition (that is to ensure that the highest leakage current which may occur will be measured) the procedure shall be carried out in such a way that all of the four possible holder contact/cap-pin combinations are covered.
- For control gear with multi-lamp operation, the leakage current from each lamp position is measured separately.
- Where a range of control gear are submitted for test, each ballast type shall be checked, not just the higher or lower power variants.
- Under each of the specified operation conditions, the capacitive leakage current measured shall not exceed the limits specified in Figure 5 (with the time ranges given in 5a, 5b and 5c).

NOTE Leakage currents are derived from IEC 60479-2.

Dimensions in millimeters

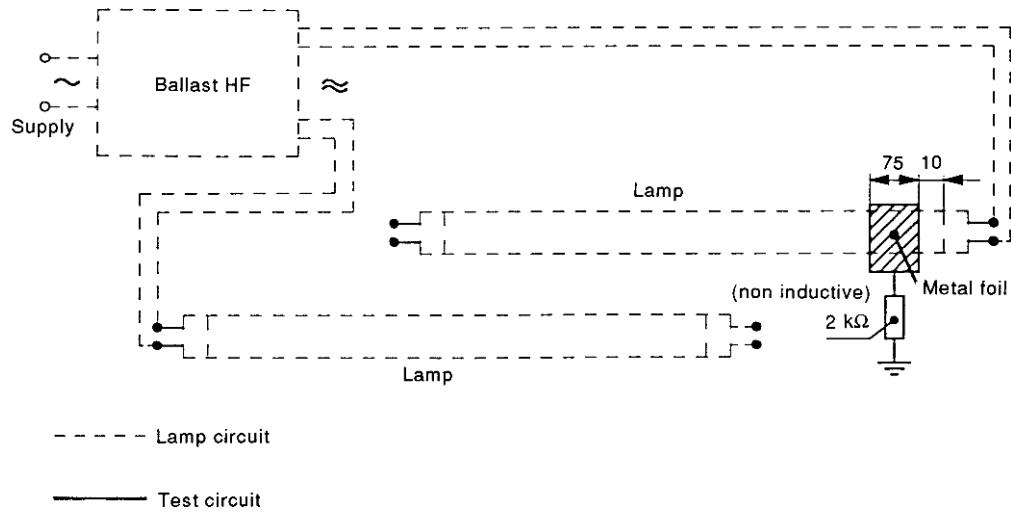

IEC 597/2000

Figure I.1a – Test arrangement for bar-shaped tubular fluorescent lamps

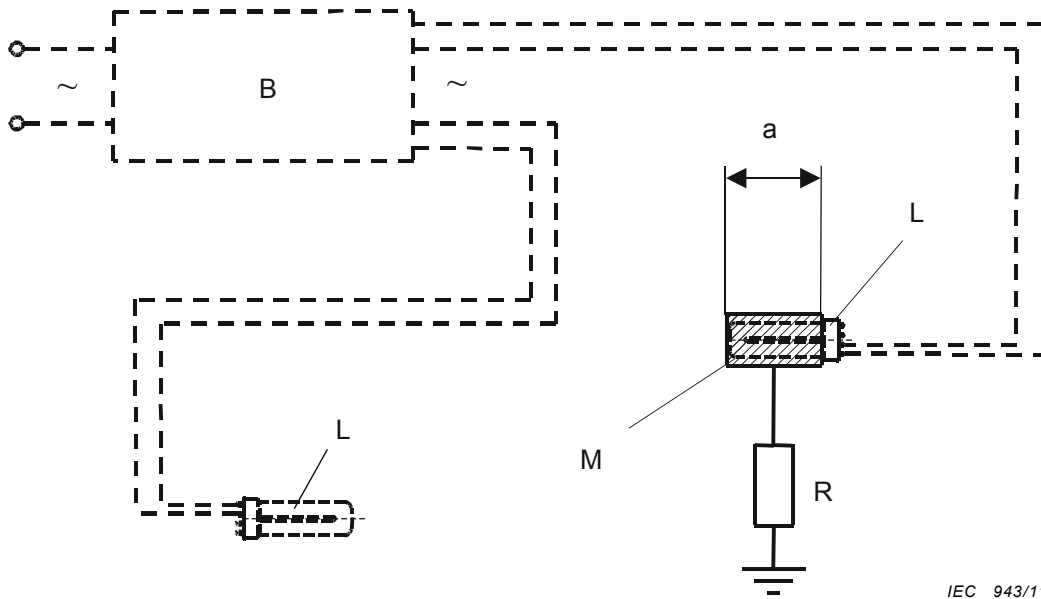

IEC 943/11

Figure I. 1b – Test arrangement for lamps with ILCOS FSD (H)...

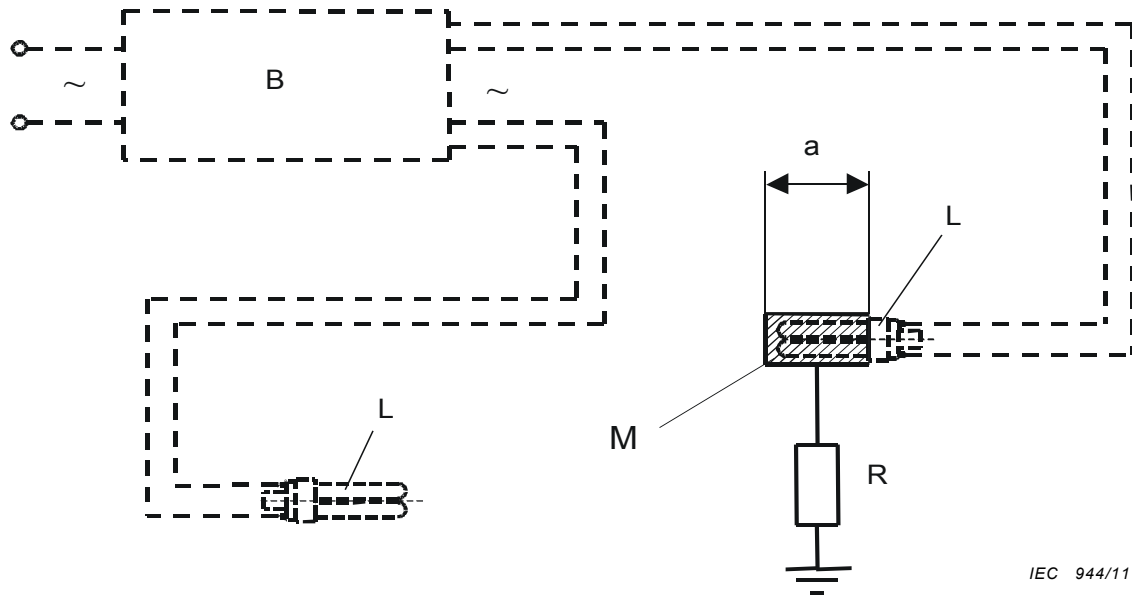

Figure I. 1c- Test arrangement for lamps with ILCOS FSQ...

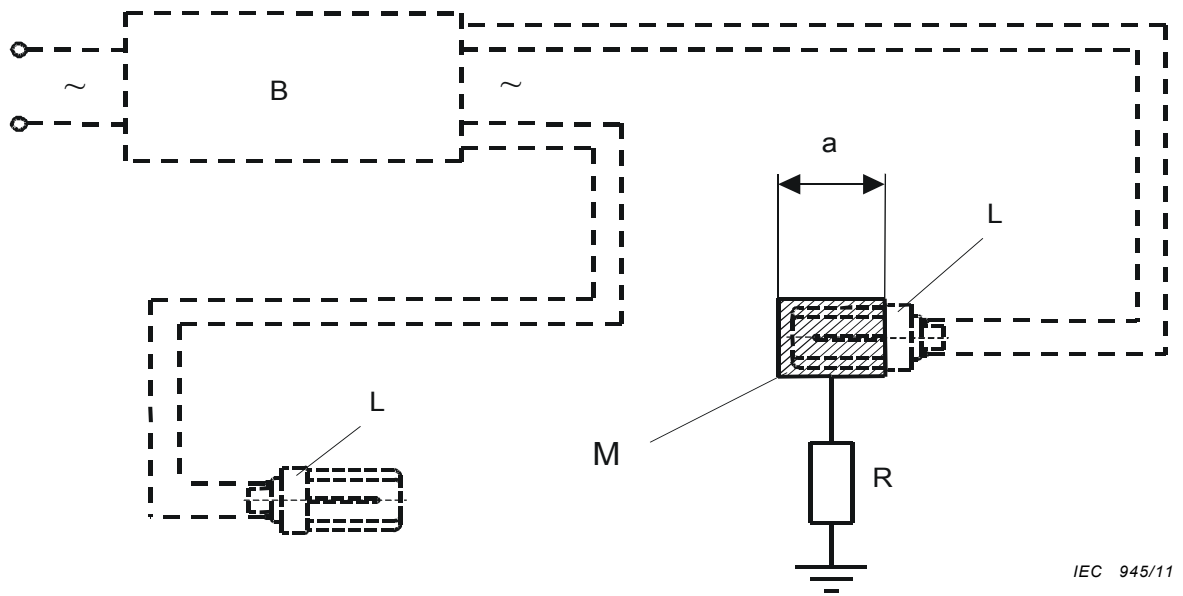

Figure I. 1d - Test arrangement for lamps with ILCOS FSM (H)...

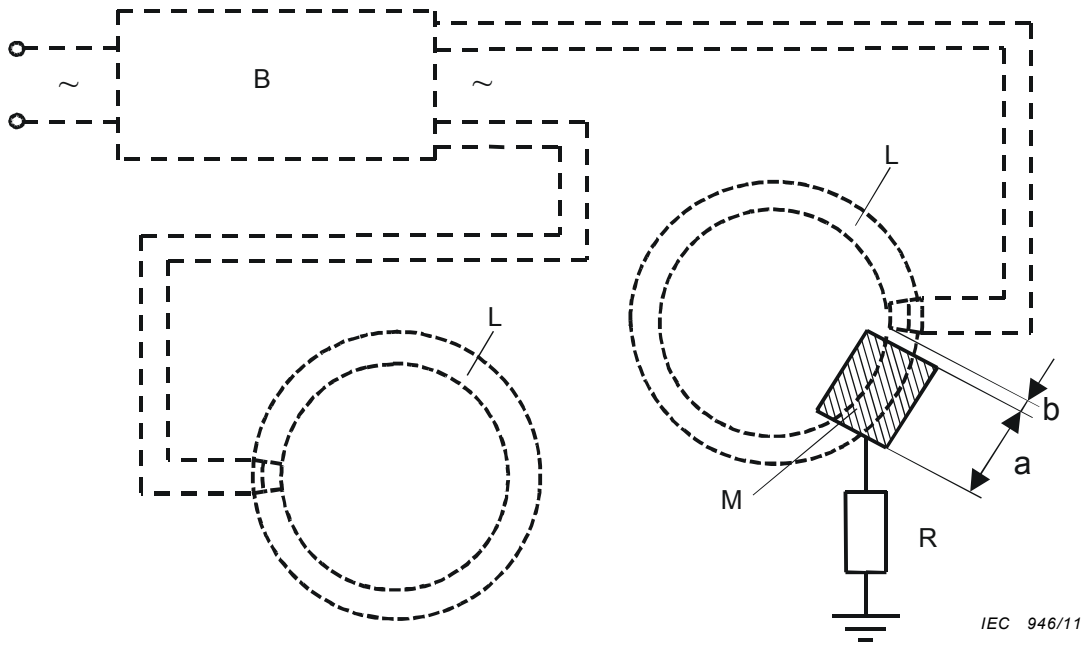

Figure I. 1e – Test arrangement for lamps with ILCOS FSC...

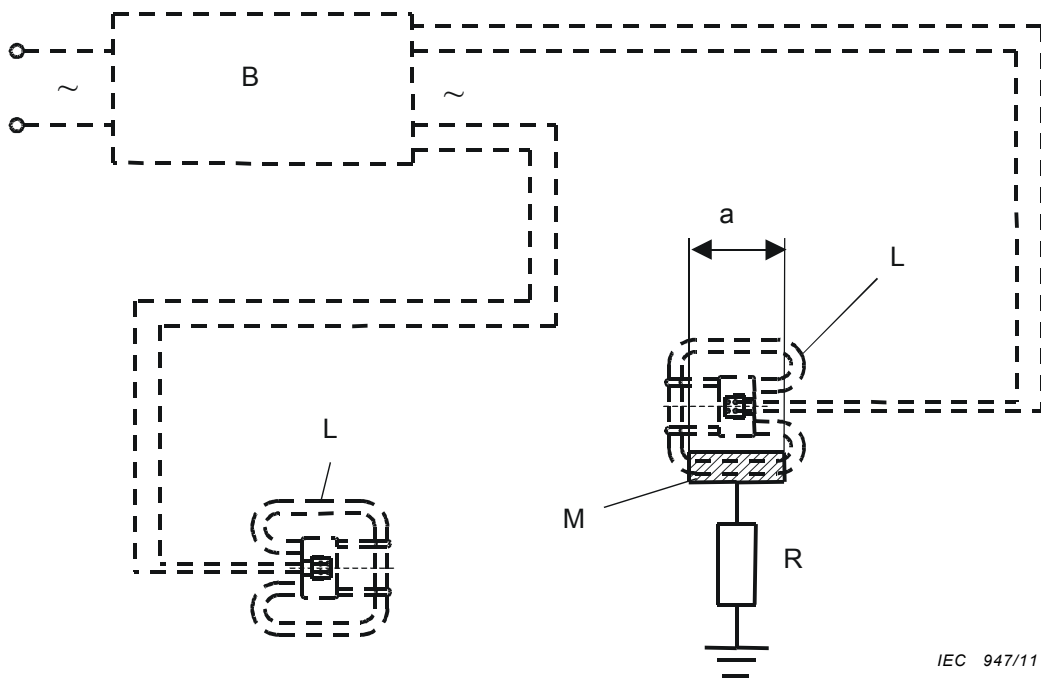

Figure I.1f– Test arrangement for lamps with ILCOS FSS...and GR10q cap

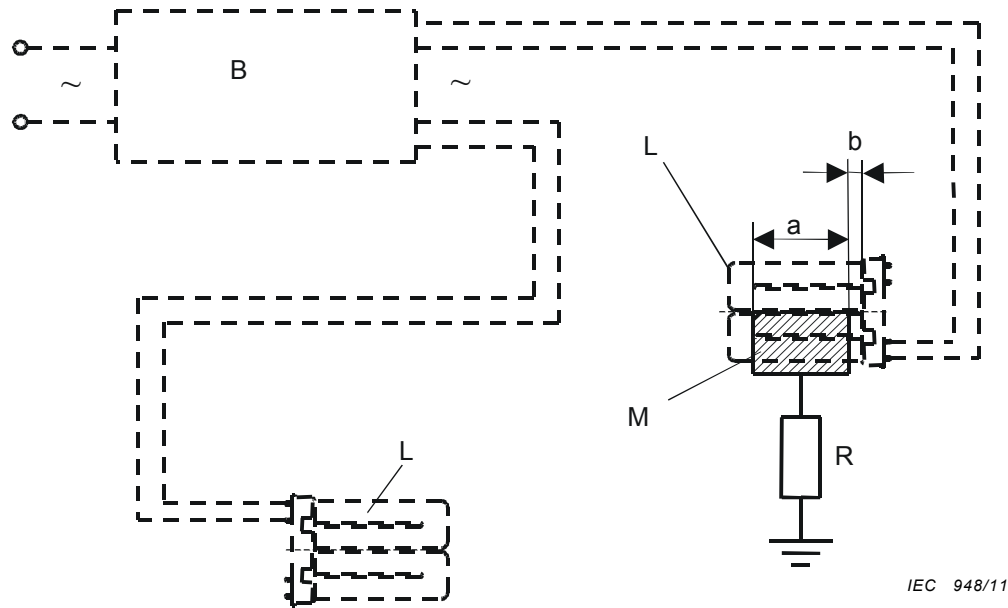

Figure I.1g – Test arrangement for lamps with ILCOS FSS...and 2G10 cap

Key to Figures I.1a to I.1g

M	metal foil	-----	lamp circuit
L	lamp	—————	test circuit
B	ballast HF		
R =	2 k Ω (non inductive)		
a =	length of the metal foil (maximum 75 mm, minimum the length of the lamp)		
b =	10 mm		

Figure I.1 – Leakage current test arrangement for various fluorescent lamps

Annex J (normative)

Particular additional safety requirements for a.c., a.c./d.c. or d.c. supplied electronic control gear for emergency lighting

J.1 General

This annex specifies particular safety requirements of a.c., a.c./d.c. or d.c. supplied electronic control gear for emergency lighting purposes intended for connection to a centralised emergency power supply, as, for example, central battery supply system.

It does not apply to electronic control gear used in self-contained emergency lighting luminaires as this is covered by IEC 61347-2-7.

J.2 Terms and definitions

The terms and definitions in Clause 3 apply together with the following.

J.2.1

emergency lighting

lighting provided for use when the supply to the normal lighting fails; it includes escape lighting and standby lighting

J.2.2

rated battery voltage

voltage declared by the battery manufacturer

J.2.3

rated emergency power supply voltage

rated voltage of the emergency power supply claimed by the manufacturer for the information of the installer or user

J.2.4

starting aid

device which facilitates the starting of the lamp

NOTE A conductive strip affixed to the outer surface of the lamp and a conductive plate which is spaced within an appropriate distance from a lamp are examples of starting aids.

J.2.5

ballast lumen factor

ratio of the luminous flux of a reference lamp when the control gear under test is operated at its rated voltage and frequency compared with the luminous flux of the same lamp operated with the appropriate reference ballast supplied at its rated voltage and frequency

J.2.6**emergency ballast lumen factor****EBLF**

ratio of the emergency luminous flux of the lamp supplied by the emergency control gear to the luminous flux of the same lamp operated with the appropriate reference ballast at its rated voltage and frequency

The emergency ballast lumen factor is the minimum of the values measured at the appropriate time after failure of the normal supply and continuously.

J.2.7**total circuit power**

total power dissipated by ballast and lamp in combination, at rated voltage and frequency of the ballast

J.2.8**preheat starting**

type of circuit in which the lamp electrodes are brought to emission temperature before the lamp actually ignites

J.2.9**non-preheat starting**

type of circuit which utilizes a high open-circuit voltage causing field emission from electrodes

J.3 Marking**J.3.1 Mandatory markings**

Control gear shall, in addition to the requirements of 7.1, be clearly marked with the following mandatory marking:

- a) a.c., a.c./d.c. or d.c. maintained emergency electronic control gear shall be marked with the symbol:



- b) rated emergency power supply voltage and voltage range.

J.3.2 Information to be provided if applicable

In addition to the above mandatory markings and the requirements of 7.2, the following information shall either be given on the control gear or be made available in the manufacturer's catalogue or similar:

- a) a clear indication regarding the type of starting, i.e. preheat or non-preheat;
b) indication whether a starting aid is needed for the lamp(s);
c) limits of the ambient temperature range within which an independent control gear will operate satisfactorily at the declared voltage (range);
d) emergency ballast lumen factor (EBLF).

J.4 General statement

The provisions of Clause 6 of IEC 60929 apply at 90 % and 110 % of the rated emergency power supply voltage.

Furthermore, starting and operation of lamps shall be guaranteed across the widest rated voltage range.

NOTE 1 The electrical characteristics, as given on the lamp data sheets of IEC 60081 and IEC 60901, and applying to operation on a reference ballast at rated voltage with a frequency of 50 Hz or 60 Hz, may deviate when operating on a high-frequency ballast and the conditions of item c) of J.3.2 above.

NOTE 2 A starting aid is only effective when it has an adequate potential difference from one end of the lamp.

J.5 Starting conditions

The provisions of Clause 7 of IEC 60929 apply at 90 % and 110 % of the rated emergency power supply voltage. Where control gear is declared for operation at temperatures lower than 10 °C then the starting condition shall be made at the lowest declared temperature and 90 % of rated voltage.

J.6 Operating conditions

The provisions of Clause 8 of IEC 60929 apply. In addition, tests shall be made with rated d.c. supply voltage.

J.7 Current

At the rated operating voltage, the supply current shall not differ by more than ± 15 % from the declared value when the control gear is operated with a reference lamp.

The supply shall be of low impedance and low inductance.

Compliance is checked by measurement.

J.8 Maximum current in any lead to a cathode

The provisions of Clause 11 of IEC 60929 apply at 90 % and 110 % of the rated emergency power supply voltage.

J.9 Lamp operating current waveform

The provisions of Clause 12 of IEC 60929 apply. In addition, tests shall be made with rated emergency power supply voltage.

J.10 EMC immunity

For emergency supplied electronic control gear, the requirements of IEC 61547 apply.

J.11 Pulse voltage from central battery systems

The d.c. supplied emergency control gear shall withstand, without failure, any pulses caused by switching other equipment in the same circuit.

Compliance is checked by operating the ballast at the maximum voltage of the rated voltage range in association with the appropriate number of lamps and in an ambient temperature of 25 °C. The control gear shall withstand, without failure, the number of pulse voltages given in Table J.1 superimposed, with the same polarity, on the supply voltage.

Table J.1 – Pulse voltages

Number of voltage pulses	Pulse voltage		Period between each pulse
	Peak value V	Pulse width at half peak ms	
3	Equal to design voltage	10	2
NOTE A suitable measuring circuit is shown in Figure G.2 of IEC 61347-1.			

J.12 Tests for abnormal conditions

The provisions of Clause 14 of IEC 60929 apply.

J.13 Temperature cycling test and endurance test

The provisions of Clause 26 of IEC 61347-2-7 apply.

J.14 Functional safety (EBLF)

The appropriate lamp associated to the control gear shall provide the necessary light output after change over to the emergency mode. This is verified if the declared emergency ballast lumen factor (EBLF) is achieved during emergency operation at 25 °C.

Compliance is checked by the following test:

Measurement of EBLF shall be made at 25 °C, using a lamp which has been aged for at least 100 h of the appropriate type and having not been lit for 24 h. The first measurement is made at maximum power supply voltage range after 5 s and 60 s and then in steady conditions at minimum power supply voltage range.

The lowest value of the values measured at 60 s with maximum power supply voltage or in steady conditions at minimum power supply voltage shall be retained and compared with the one measured with the same lamp operating by the appropriate reference ballast. The ratio shall reach at least the declared EBLF.

The value measured at 5 s at maximum power supply voltage shall reach at least 50 % of declared EBLF.

NOTE 1 Replace 60 s by 0,5 s for ballasts declared for use in luminaires for high-risk task area lighting.

NOTE 2 Other methods may apply for determining EBLF, in particular methods which record permanently the luminous flux of the lamp associated to the ballast under test.

Annex K
(informative)

Components used in the asymmetric pulse test circuit
(see Figure 1)

Table K.1 – Material specification

Reference designation	Description
U1	555 timer ic
T1	1:1 transformer
D1, D2	Ultra fast recovery diode, 1 000 V, 1 A, 75 ns
D3, D4	Signal diode 75 V 200 mA
D5...D8	200 V Zener diode
Q1	Mosfet 900 V 6 A
R1A to R1C	Resistor 5 kΩ 25 W 1 %
R2A and B	Resistor 500 Ω 30 W 1 %
S1, S3, S4	Switch
S2	Switch – double
Battery	Battery 9 V
C1, C2, C3	Capacitor 0,1 μF 50 V 5 %
R3	Resistor 30 Ω ¼ W 5 %
R4	Resistor 365 kΩ ¼ W 1 %
R5	Resistor 41,2 kΩ ¼ W 1 %
R6	Resistor 44,2 kΩ ¼ W 1 %

Table K.2 – Transformer specification

Component	Description
Core	Two EI187 (E19/8/5), Core area 22,6 mm ² , P material or equivalent
Bobbin	8-pin, horizontal mount
Primary winding	38 turns #26 AWG HN, 19 turns/layer. Start pin 5, finish pin 7
Inter-winding insulation	5 layers 3M #56 3/8" or equivalent
Secondary winding	38 turns #26 AWG HN, 19 turns/layer. Start pin 4, finish pin 1
Wrapper	2 layers 3M #56 3/8" or equivalent
Inter-winding capacitance	Approximately 22 pF
HIPOT	2 500 V _{rms}

Annex L (normative)

Information for control gear design (from Annex E of IEC 61195)

L.1 Guideline for safe lamp operation

To ensure safe lamp operation, it is essential to observe Clause L.2

L.2 Limitation of working voltage

For G5-capped lamps with diameter 16 mm, the working voltage between any lamp terminal and earth shall not exceed 430 V r.m.s.

Bibliography

IEC/TS 60479-2, *Effects of currents on human beings and livestock – Part 2: Special aspects*

IEC 60598-2-22, *Luminaires – Part 2-22: Particular requirements – Luminaires for emergency lighting*

IEC 61195, *Double-capped fluorescent lamps – Safety specifications*

IEC 61199, *Single-capped fluorescent lamps – Safety specifications*

INTERNATIONAL
ELECTROTECHNICAL
COMMISSION

3, rue de Varembé
PO Box 131
CH-1211 Geneva 20
Switzerland

Tel: + 41 22 919 02 11
Fax: + 41 22 919 03 00
info@iec.ch
www.iec.ch

SRI LANKA STANDARDS INSTITUTION

The Sri Lanka Standards Institution (SLSI) is the National Standards Organization of Sri Lanka established under the Sri Lanka Standards Institution Act No. 6 of 1984 which repealed and replaced the Bureau of Ceylon Standards Act No. 38 of 1964. The Institution functions under the Ministry of Technology & Research.

The principal objects of the Institution as set out in the Act are to prepare standards and promote their adoption, to provide facilities for examination and testing of products, to operate a Certification Marks Scheme, to certify the quality of products meant for local consumption or exports and to promote standardization and quality control by educational, consultancy and research activity.

The Institution is financed by Government grants, and by the income from the sale of its publications and other services offered for Industry and Business Sector. Financial and Administrative control is vested in a Council appointed in accordance with the provisions of the Act.

The development and formulation of National Standards is carried out by Technical Experts and representatives of other interest groups, assisted by the permanent officers of the Institution. These Technical Committees are appointed under the purview of the Sectoral Committees which in return are appointed by the Council. The Sectoral Committees give the final Technical approval for the Draft National Standards prior to the approval by the Council of the SLSI.

All members of the Technical and Sectoral Committees render their services in an honorary capacity. In this process the Institution endeavours to ensure adequate representation of all view points.

In the International field the Institution represents Sri Lanka in the International Organization for Standardization (ISO), and participates in such fields of Standardization as are of special interest to Sri Lanka.

SLS CERTIFICATION MARK

The Sri Lanka Standards Institution is the owner of the registered certification mark shown below. Beneath the mark, the number of the Sri Lanka Standard relevant to the product is indicated. This mark may be used only by those who have obtained permits under the SLS certification marks scheme. The presence of this mark on or in relation to a product conveys the assurance that they have been produced to comply with the requirements of the relevant Sri Lanka Standard under a well designed system of quality control inspection and testing operated by the manufacturer and supervised by the SLSI which includes surveillance inspection of the factory, testing of both factory and market samples.

Further particulars of the terms and conditions of the permit may be obtained from the Sri Lanka Standards Institution, 17, Victoria Place, Elvitigala Mawatha, Colombo 08.

