

SRI LANKA STANDARD 1216 : 2001
IEC 247 : 1978

MEASUREMENT OF
RELATIVE PERMITTIVITY, DIELECTRIC
DISSIPATION FACTOR AND D.C
RESISTIVITY OF INSULATING LIQUIDS

SRI LANKA STANDARDS INSTITUTION

**MEASUREMENT OF
RELATIVE PERMITTIVITY, DIELECTRIC DISSIPATION FACTOR AND D.C
RESISTIVITY OF INSULATING LIQUIDS**

**SLS 1216 : 2001
IEC 247 : 1978**

Gr. J

**SRI LANKA STANDARDS INSTITUTION
17, Victoria Place,
Elvitigala Mawatha,
Colombo 8,
Sri Lanka.**

Sri Lanka Standards are subject to periodical revision in order to accommodate the progress made by industry. Suggestions for improvement will be recorded and brought to the notice of the Committees to which the revisions are entrusted.

This standard does not purport to include all the necessary provisions of a contract.

© SLSI 2001

All rights reserved. Unless otherwise specified, no part of this publication may be reproduced or utilized in any form or by any means, electronic or mechanical, including photocopying and microfilm, without permission in writing from the SLSI.

SLS 1216 :2001
IEC 247 : 1978

Sri Lanka Standard
MEASUREMENT OF RELATIVE PERMITTIVITY, DIELECTRIC DISSIPATION
FACTOR AND D.C. RESISTIVITY OF INSULATING LIQUIDS

NATIONAL FORWAORD

This standard was approved by the sectoral committee on Electric Cables and Conductors on 2000-11-24 and was authorized for adoption as a Sri Lanka Standard by the Council of the Sri Lanka Standards Institution on 2001-05-22.

This Sri Lanka Standard is identical with IEC 247 : 1978 Measurement of relative permittivity, electric dissipation factor and d,c, resistivity of insulating liquids, published by International Electrotechnical Commission(IEC).

Although reference has been made to 'askarels' the usage of the same is not encouraged as askarels can cause a number potential environmental hazards.

Terminology and conventions

The text of the International Standard has been accepted as suitable for publication, without any deviation as a Sri Lanka Standard. However certain terminology and conventions are not identical with those used in Sri Lanka Standards attention is therefore drawn to the following.

- a) Wherever the words "International Standard" appear referring to this standard they should be interpreted as "Sri Lanka Standard"
- b) Wherever page numbers are quoted they are page numbers of IEC standard.

CONTENTS

Clause	Page
FOREWORD	5
PREFACE	5
1. Scope	7
2. Definitions	7
3. General considerations	9
4. Apparatus	11
5. Cleaning solvent	15
6. Cleaning the test cell	15
7. Sampling	17
8. Conditioning and preparation of specimens	17
9. Filling the test cell	19
10. Test temperature	19
11. Measurement of dissipation factor	19
12. Measurement of relative permittivity	21
13. Measurement of d.c. resistivity	23
APPENDIX A – Alternative procedures for routine testing of dielectric dissipation factor and resistivity of insulating liquids	27



INTERNATIONAL ELECTROTECHNICAL COMMISSION

**MEASUREMENT OF RELATIVE PERMITTIVITY,
DIELECTRIC DISSIPATION FACTOR AND
D.C. RESISTIVITY OF INSULATING LIQUIDS**

FOREWORD

- 1) The formal decisions or agreements of the IEC on technical matters, prepared by Technical Committees on which all the National Committees having a special interest therein are represented, express, as nearly as possible, an international consensus of opinion on the subjects dealt with.
- 2) They have the form of recommendations for international use and they are accepted by the National Committees in that sense.
- 3) In order to promote international unification, the IEC expresses the wish that all National Committees should adopt the text of the IEC recommendation for their national rules in so far as national conditions will permit. Any divergence between the IEC recommendation and the corresponding national rules should, as far as possible, be clearly indicated in the latter.

PREFACE

The first edition of this standard was prepared by IEC Technical Committee No. 15, Insulating Materials, and was published in 1967 with the title: Recommended Test Cells for Measuring the Resistivity of Insulating Liquids and Methods of Cleaning the Cells.

Following the publication of this standard, in view of amendments made to the scopes of both Technical Committee No. 15 and Technical Committee No. 10, it was agreed that responsibility for its revision, or for the publication of such supplements as might be required, would pass to Technical Committee No. 10, Liquid and Gaseous Dielectrics.

In 1970 Technical Committee No. 10 considering that it was advisable to cover the whole subject of the measurement of dielectric properties of insulating liquids in a single publication, undertook revision of this standard with an extended scope.

Drafts were discussed at the meeting held in Baden-Baden in 1975. As a result of this meeting, a draft, Document 10(Central Office)222, was submitted to the National Committees for approval under the Six Months' Rule in September 1976.

The following countries voted explicitly in favour of publication:

Australia	Japan
Austria	Netherlands
Belgium	Norway
Canada	Poland
Czechoslovakia	Spain
Denmark	South Africa (Republic of)
Egypt	Switzerland
Finland	Turkey
France	Union of Soviet Socialist Republics
Germany	United Kingdom
Hungary	United States of America
Italy	Yugoslavia

Other IEC publications quoted in this standard:

- Publications Nos. 93: Recommended Methods of Test for Volume and Surface Resistivities of Electrical Insulating Materials.
- 250: Recommended Methods for the Determination of the Permittivity and Dielectric Dissipation Factor of Electrical Insulating Materials at Power, Audio and Radio Frequencies including Metre Wavelengths.
- 475: Method of Sampling Liquid Dielectrics.

MEASUREMENT OF RELATIVE PERMITTIVITY, DIELECTRIC DISSIPATION FACTOR AND D.C. RESISTIVITY OF INSULATING LIQUIDS

1. Scope

This standard describes methods for the determination of dielectric dissipation factor, relative permittivity and d.c. resistivity of hydrocarbons and askarels* which are liquid at the test temperature.

The methods are primarily intended for making reference tests on unused liquids but they may also be applied to liquids in service in transformers, cables and other electrical apparatus. However, when it is desired to make routine determinations, simplified procedures, as described in Appendix A, may be adopted.

The test procedures described may be used successfully with insulating liquids other than hydrocarbon liquids and askarels, though it is recognized that alternative cleaning procedures may be required.

2. Definitions

2.1 Permittivity (*relative*)

The relative permittivity of an insulating material is the ratio of capacitance C_x of a capacitor in which the space between and around the electrodes is entirely and exclusively filled with the insulating material in question, to the capacitance C_0 of the same configuration of electrodes in vacuum.

The capacitance C_a of the configuration of electrodes in air can normally be used instead of C_0 to determine the relative permittivity with sufficient accuracy.

2.2 Dielectric dissipation factor

The dielectric dissipation factor ($\tan \delta$) of an insulating material is the tangent of the loss angle.

The loss angle is the angle by which the phase difference between applied voltage and the resulting current deviates from $\pi/2$ rad when the dielectric of the capacitor consists exclusively of the insulating material.

2.3 D.C. resistivity (*volume*)

The volume resistivity of an insulating material is the quotient of a d.c. electrical field strength and the steady state current density within the material.

The unit of resistivity is the ohm meter (Ωm).

* The term askarel describes a broad class of insulating liquids that, being totally or partly based on polychlorobiphenyls, can be persistent environmental contaminants.

Care is needed in handling or disposing of them to prevent entry into the environment.

3. General considerations

3.1 *Permittivity and dielectric dissipation factor*

The permittivity and the dielectric dissipation factor of electrical insulating liquids depend to a considerable extent on the test conditions under which they are measured, in particular on the temperature and on the frequency of the applied voltage. Permittivity and dissipation factor are the results of dielectric polarization and conductance of the material.

At power frequency and sufficiently high temperature, as recommended in these methods, the losses may exclusively be attributable to the conductance of the liquid, that is, to the presence of free charge carriers in the liquid. Measurements of the dielectric properties of high purity insulating liquids are therefore of value as an indication of the presence of ionizable contaminants.

The contribution to dielectric losses from the conductance of the liquid is inversely dependent on measuring frequency and varies with the viscosity of the medium. The value of the test voltage when measuring the dissipation factor is less important. It is often governed by the sensitivity of the measuring bridge. However, it must be borne in mind that too high a voltage stress results in secondary phenomena at the electrodes, dielectric heating, discharges, etc.

While relatively large amounts of impurities produce a comparatively small change in permittivity, the dissipation factor of insulating liquids may be strongly affected by traces of ionizable dissolved contaminants or colloidal particles. Askarels are much more sensitive to contamination than hydrocarbon liquids due to their higher polarity, which results in turn in higher solvent power and dissociation capability. Therefore they require comparatively greater care in handling than hydrocarbon liquids.

Unreliable results usually originate from contamination due to improper sampling or handling of liquid specimens, from incomplete cleaning of the cells or from the presence of undissolved water.

Long exposure to strong light during storage may lead to deterioration with high results. Standardized procedures for the storage and transfer of the liquid samples and for the construction and cleaning of test cells shall be recommended so that errors caused by contamination are minimized.

Erratic results may arise from the time dependence of dissipation factor measurements. In fact, when an insulating liquid is introduced into a cell heated to a constant temperature, its dissipation factor may significantly change with time even in absence of electrical stress. The magnitude of the time effect is more important with askarels. The rate of the change depends on the ratio of area of electrodes to volume of liquid and on the test temperature.

Since the initial value is thought to be representative of the actual condition of the liquid it appears most desirable that dissipation factor should be measured as soon as temperature equilibrium has been reached. The dissipation factor is very sensitive to changes of temperature, the dependence on $1/K$ being exponential. It is therefore necessary to carry out measurements under sufficiently precise temperature conditions. The procedure described below allows the time necessary for the test specimen to attain temperature equilibrium with the test cell to be kept to a minimum.

3.2 Resistivity

Measurements of d.c. resistivity of liquids depend on a number of test conditions, namely:

a) *Temperature*

Resistivity is particularly sensitive to changes of temperature, the dependence on $1/K$ being exponential. It is therefore necessary to carry out measurements under sufficiently precise temperature conditions.

b) *Magnitude of the electrical field*

The resistivity of a given specimen may be influenced by the applied stress. For results to be comparable, measurements shall be made with approximately equal voltage gradients.

c) *Time of electrification*

Upon the application of d.c. voltage the current flow through the specimen decreases towards a limiting value due to the sweep of charge carriers to the electrodes. The conventional arbitrary time of electrification is 1 min. Variation in the time of electrification can result in appreciable variation in the test results.

D.C. resistivity is strongly affected by contamination of the specimen and is time dependent. Exactly the same precautions as described in Sub-clause 3.1 should be strictly followed in order to prevent erratic results from improper handling of the liquid sample and test cells or from time effects. As with dissipation factor, ionizable and colloidal impurities also affect resistivity. The presence of water in a dispersed state may significantly reduce resistivity. Dissolved water may become significant when it approaches saturation levels.

Despite all the above factors which influence the scientific significance of the results, d.c. resistivity continues to be a useful criterion.

3.3 *Sequence of the determinations*

When permittivity, dissipation factor and resistivity measurements are to be made consecutively on the same specimen, the a.c. determination shall always be made before applying the d.c. voltage to the specimen. The cell electrodes should be short-circuited for 1 min after the a.c. test and resistivity measurement started immediately after.

4. Apparatus

4.1 *Test cell*

The same test cell can be used for measurements of permittivity, dissipation factor and d.c. resistivity. A cell suitable for these purposes shall meet the following general requirements:

- 1) The design of the cell shall be such as to allow easy dismantling for cleaning of all its parts and reassembling without significantly changing the capacitance of the empty cell. The design shall also permit the use of the cell in a suitable constant temperature bath or oven and shall provide means to measure the temperature of the inner electrode.

- 2) The materials used in constructing the cell shall be non-porous and capable of withstanding the required temperature satisfactorily. The alignment of the electrodes shall not be influenced by change of temperature.
- 3) The surfaces of the electrodes in contact with the liquid under test shall have a mirror-like finish to make their cleaning easier. There should be no chemical interactions between the liquids under test and the electrodes. These should also be unaffected by the cleaning materials. Cells made of stainless steel have been found satisfactory for testing all types of insulating liquids. Aluminium or its alloys should not be used because they may be attacked by alkaline detergents.

Note. — Generally, plated surfaces have been found less satisfactory than solid metal electrodes. However, surfaces plated with gold, nickel or rhodium have been found satisfactory provided they are well plated and remain undamaged. Rhodium-plated invar has been found satisfactory and has the additional advantage of low thermal expansion. Nickel- or gold-plated brass and nickel-plated stainless steel have also been used.

- 4) Solid insulation materials used to support the electrodes shall have a low dissipation factor and a high resistivity. They should not absorb or be adversely affected by reference liquids, test liquids or cleaning materials.

Note. — Fused silica is generally considered to be a suitable material for use as an insulating material in the cell. As a consequence of the difference between the coefficients of linear expansion of usual metals and of fused silica, a sufficient radial clearance is necessary between the joints. This clearance may decrease the accuracy of electrode centring.

- 5) The distance, across the surface of the liquid and across the solid insulating material, between the guard electrode and the measuring electrode shall be great enough to withstand the test voltage used.
- 6) Examples of cells which may be used with low viscosity liquids and up to 2000 V are shown diagrammatically in Figure 1, page 30 (three-terminal cell), and in Figure 2, page 32 (two-terminal cell). Any similar cell which meets the requirements given above may be used. In the three-terminal cells provision is made for an efficient guard-ring system which adequately shields the measuring electrode. Three-terminal cells are to be preferred when the most accurate determinations are to be made. In the case of measurements for which special screening is required a removable screening cup can be added and electrically bonded to the outer conductor of the coaxial cable used for the connection to the bridge (see Figure 1a, page 31).

With two-terminal cells, the shield on the lead usually connected to the guard electrode shall be securely clipped to the cable insulation in order to prevent contact with any other surface. When these cells are used for resistivity measurements it should be established that the resistance across the insulators, with the cell empty, is at least 100 times the resistance which is measured through the liquid. For a.c. measurements corresponding values for dissipation factor shall be established.

The cell shall always be cleaned immediately before use in a reference test. Cleaning need not precede a routine measurement made subsequent to one in which the property measured was within the limiting value specified. After use and when test cells are not to be used for several days, they shall be cleaned and dried in accordance with Clause 6, assembled and stored in a dry and dust-free cabinet.

It may be found desirable to restrict the use of a cell to a particular class of liquid.

4.2 Test chamber

The test chamber shall be adequate to maintain its temperature within $\pm 0.5^{\circ}\text{C}$ of the prescribed value. It may consist of a forced draught air oven or of an oil or glycerol filled thermostatically controlled bath fitted with a shelf to support the cell.

The test chamber shall provide screened electrical connections to the cell. The test cell shall be properly insulated from the earthed enclosure of the chamber.

4.3 *Glassware*

Ordinary chemical glassware made of borosilicate glass such as beakers, graduated cylinders, pipettes, etc., shall be used.

All glassware used in handling samples shall be cleaned at least to the standard specified in Clause 6, and carefully dried.

4.4 *Measuring instrument for permittivity and dissipation factor*

An a.c. (power frequency) bridge, capable of measuring loss tangent with a resolution down to 1×10^{-4} for normal application but preferably capable of measuring down to 1×10^{-5} in a capacitance of 100 pF.

Full details of a.c. capacitance bridge and testing circuit may be found in IEC Publication 250: "Recommended Methods for the Determination of the Permittivity and Dielectric Dissipation Factor of Electrical Insulating Materials at Power, Audio and Radio Frequencies Including Metre Wavelengths".

4.5 *Measuring instrument for d.c. resistivity*

Suitable instruments and test circuit are described in IEC Publication 93: Recommended Methods of Test for Volume and Surface Resistivities of Electrical Insulating Materials.

4.6 *Time-measuring device*

Accurate to 0.5 s, for measuring the time of electrification.

5. **Cleaning solvent**

Solvent used for cleaning the test cell shall have a purity at least corresponding to the requirements for technical grades and shall be stored in brown glass bottles.

If delivered in drums it shall be filtered and stored in brown glass bottles.

Chlorinated solvents, such as 1.1.1 trichloroethane, perchloroethylene and chloroform, are required for testing askarels. Hydrocarbon solvents, such as petroleum spirit (boiling point 60°C to 80°C), n-heptane and toluene, are suitable for hydrocarbon oils.

Note.— Chlorinated solvents containing certain types of low-volatility stabilizing additives may sometimes require distillation shortly before use.

6. **Cleaning the test cell**

The cleanliness of the test cell is of paramount importance when measuring dielectric properties because of the extreme susceptibility of insulating liquids to the influence of the most minute contamination.

It is essential therefore that the procedure outlined below shall be closely followed:

- Dismantle the cell completely.
- Wash all the component parts thoroughly with two portions of the solvent (see Clause 5).

- Rinse all parts with acetone and then wash them with a mild abrasive soap or mild abrasive detergent.
Abrasive particles and rubbing action should be such as to cause no deterioration of the mirror-like finish of metal surfaces.
- Boil all parts for at least 5 min in 5% trisodium phosphate solution in distilled water followed by several rinsings with distilled water.
- Boil all parts in distilled water for at least 1 h.
- Thoroughly dry the component parts in an oven heated at 105°C to 110°C for no longer than 90 min because certain materials may deteriorate. Drying time depends on the design of the cell but usually 60 min to 90 min is satisfactory to remove any moisture.

After the electrodes have been washed take care not to touch their surfaces with bare hands.

Also pay attention to the cleanliness of surfaces on which cell components are placed. Do not expose them to contamination from vapours or dust.

Note. — Appropriate precaution against fire and toxic effects on personnel shall be observed when using solvents.

7. Sampling

Insulating liquids for use in these tests shall be sampled in accordance with the method described in IEC Publication 475: Method of Sampling Liquid Dielectrics.

8. Conditioning and preparation of specimens

Samples, obtained in accordance with Clause 7, shall be stored in their original containers and shielded from light.

Unless specifically required by the specification relevant to the liquid under test, no treatment, such as filtration, drying, etc., shall be applied. Whenever it is possible, preheat the sample in the original sample container after transfer of sufficient sample for other tests. Sufficient space shall be left for the expansion of the liquid to avoid breakage of the container. Where samples have to be transferred to other containers these shall be glass beakers or glass-stoppered Erlenmeyer flasks cleaned in accordance with Sub-Clause 4.3. Before taking specimens the original container shall be allowed to stand in the room in which the tests are made until the sample attains ambient temperature.

In order that representative specimens may be obtained, the sample is homogenized by tilting the container and gently swirling the liquid several times.

Wipe the mouth of the container with a clean lint-free cloth and pour off a small portion of the liquid to wash the external surface.

The sample container or the auxiliary receptacles are stoppered and the liquid heated in an oven to a temperature 5°C to 10°C above the required test temperature.

With liquids which are susceptible to oxidation the heating period shall not exceed 1 h.

Because of contamination effects, it may be found desirable to restrict the use of an oven to a particular class of liquid.

9. Filling the test cell

Assemble the test cell whilst still hot, taking care not to touch the surfaces of the electrodes or insulation which will be wetted by the liquid.

Transfer the assembled cell to the oven maintained at 5°C to 10°C above the required test temperature. When the temperature of the inner electrode(s) has exceeded the test temperature, quickly remove the cell, lift out the inner electrode(s) (do not rest them on any surface) and fill the cell with a portion of the heated sample.

Replace the remainder of the heated sample in the oven, insert the inner electrode(s) and rinse the cell by twice raising and lowering the inner electrode(s). Lift out the inner electrode(s) (do not rest them on any surface), discard the rinsing fluid and immediately refill the cell with a second portion of the heated sample. Replace the inner electrode(s), transfer the cell to the test chamber at the test temperature and make the necessary electrical connections. Replace the remainder of the heated sample in the oven. Choose the appropriate preheating temperature and perform the operations described above as rapidly as possible to avoid cooling the cell excessively in order that the cell and contents will reach equilibrium within 10 min for reference tests and 10 min to 15 min for routine tests. Avoid also the collection of dust particles on the wetted surfaces of the cell.

Note. — If a thermometer pocket is provided in the inner electrode, insert a mercury thermometer graduated in 0.25°C increments.

10. Test temperature

These test methods are suitable for testing insulating liquids over a wide range of temperatures. Tests should be carried out at 90°C, unless otherwise specified by the appropriate specification for the particular liquid.

11. Measurement of dissipation factor

11.1 Test voltage

The a.c. voltage shall be such as to subject the liquid to an electrical stress between 0.03 kV/mm and 1 kV/mm. The voltage shall be sinusoidal at a frequency between 40 Hz and 62 Hz.

Note. — Generally, within the above range of frequency, conversion of results from one frequency to another can be made using the formula:

$$\tan \delta_{f_1} = \tan \delta_{f_2} \times \frac{f_2}{f_1}$$

11.2 Measurement

Ten minutes after filling the cell* carry out the dissipation factor measurement while the temperature of the inner electrode is within $\pm 1^\circ\text{C}$ of the required test temperature. Apply voltage only during the measurement. On completing the initial measurement, pour off the liquid and refill the cell with a second specimen of the sample following the same procedure and exercising the same precautions used in making the first filling, but omitting rinsing. Repeat the measurement. The two readings should not differ from each other by more than 0.0001 plus 25% of the higher of the two values.

* For routine tests this period may be increased from 10 min to 15 min.

If this requirement is not met, continue with further fillings till two consecutive readings are obtained which agree to within 0.0001 plus 25% of the higher value of the two values being compared. Then these shall be accepted as valid results.

Alternatively duplicate measurements may be carried out in different cells of the same pattern, in which case the readings shall comply with the requirements of the previous paragraphs.

11.3 Report

Report as the dissipation factor of the liquid sample the lower of the two valid measurements.

The report shall also include:

- a) Type of test cell(s) and its capacitance with air as the dielectric,
- b) voltage and effective electrode gap,
- c) frequency of applied voltage,
- d) temperature of test,
- e) number of fillings tested and the result on each.

12. Measurement of relative permittivity

12.1 Measurement

Measure the capacitance of the clean test cell first with dry air as the dielectric and then after filling with a liquid of known relative permittivity ϵ_n . Calculate the "electrode constant" C_e and the correction capacitance C_g from:

$$C_e = \frac{C_n - C_a}{\epsilon_n - 1}$$

$$C_g = C_a - C_e$$

where C_n = capacitance of the cell filled with the calibration liquid having the relative permittivity ϵ_n

C_a = capacitance of the cell with air as the dielectric

Measure the capacitance C_x of the cell filled with the liquid under test and calculate the relative permittivity ϵ_x from

$$\epsilon_x = \frac{C_x - C_g}{C_e}$$

Repeat the test until a repeatability of 5% of the higher value is obtained.

Notes 1. — Maximum accuracy is obtained if values C_a , C_n and ϵ_n are known at the temperature for which the value C_x is determined.

2. — When well-designed, previously checked three-terminal cells are used or where lower accuracy is acceptable, the term C_g may be neglected, and the relative permittivity may be calculated from the simplified formula:

$$\epsilon_x = \frac{C_x}{C_a}$$

12.2 Report

Report as the relative permittivity of the liquid sample the mean of the two valid measurements.

The report shall also include:

- a) Type of test cell and its capacitance with air as the dielectric,
- b) voltage and electrode gap,
- c) frequency of applied voltage,
- d) temperature of test.

13. Measurement of d.c. resistivity

13.1 Test voltage

The d.c. test voltage shall be such as to subject the liquid to an electrical stress of 250 V/mm, unless otherwise specified.

13.2 Time of electrification

The conventional time of electrification shall be 60 s.

13.3 Measurement

If the dissipation factor has been measured on the test specimen, the electrodes should be short-circuited for 1 min, and resistivity measurement started immediately after.

If only resistivity is to be measured, start the determination 10 min after filling the cell*.

Establish electrical connections to the measuring apparatus and to the voltage supply so that the positive potential lead is connected to the outer electrode of the cell. Apply d.c. voltage, and at the end of 60 s of electrification, record the current and voltage readings.

Note. — Alternatively, instruments reading in resistance may be used provided the other requirements (e.g. a stress of 250 V/mm) are complied with.

Short-circuit the cell electrodes for a period of 5 min.

Discard the liquid in the cell, pour in a second specimen from the sample and repeat the measurements.

Calculate the resistivity in ohm metres by means of:

$$\rho = K \frac{U}{I}$$

where U = reading of the test voltage, in volts

I = reading of the current, in amperes

K = cell constant in metres

The cell constant K is calculated from the capacitance according to:

$$K \text{ (metre)} = 0.113 \times \text{capacitance (pF) of the empty cell.}$$

* For routine tests 10 min may be extended to 15 min.

The two readings should not differ from each other by more than 35% of the higher of the two values. If this requirement is not met, continue with further fillings until two consecutive values of resistivity are obtained which agree to within 35% of the higher of the two values being compared.

Then these shall be accepted as valid results.

Note. —A second measurement on each filling, made with the polarity of the applied voltage reversed, may provide information on the cleanliness of the cell and other phenomena. In order to avoid erroneous results care is necessary with certain electronic instruments which do not have a switch for such reversal.

13.4 *Report*

Report as resistivity of the sample the higher of the two valid measurements.

The report should also include:

- a)* Type of test cell and the cell constant,
 - b)* voltage and electrode gap,
 - c)* number of fillings tested and the result on each,
 - d)* temperature of test.
-

APPENDIX A

ALTERNATIVE PROCEDURES FOR ROUTINE TESTING OF DIELECTRIC DISSIPATION FACTOR AND RESISTIVITY OF INSULATING LIQUIDS

A1. General

These simplified procedures are of value when testing a group of samples to ascertain whether the dissipation factor and resistivity of hydrocarbon and askarel liquids in service in electrical equipment, as well as of unused insulating liquids, are worse than certain specified values.

The test methods described in this appendix are less precise than those previously described but they allow a greater rapidity of measurement with a level of accuracy still quite acceptable.

A2. Test cell

Test cells modified to allow the replacement of the liquid without opening the cell may also be used.

It may be found desirable to restrict the use of one cell to a particular class of liquid.

A3. Test chamber

A forced draught air oven, a heating jacket or an oil (or glycerol) filled bath able to maintain the test cell at a sufficiently uniform temperature so that the required test temperature and the temperature of the inner electrode agree within 2°C. The use of a hot plate is less satisfactory because variations of temperature throughout the cell may lead to unreliable results.

A4. Test temperature

Measurements may be made when test specimens are within $\pm 2^\circ\text{C}$ of the desired temperature.

A5. Cleaning the test cell

Where the cleaning procedures described in Clause 6 cannot be used, it is imperative that each laboratory evolves a good cleaning procedure for the cell used so that results obtained are repeatable and reasonably consistent with those obtained in accordance with the more elaborate procedure described in Clause 6.

The precautions on choice of solvents outlined in Clause 5 should equally be followed.

The following procedure will often suffice for testing hydrocarbon liquids:

- Dismantle the cell completely, whenever possible.
- Wash all the component parts thoroughly with two portions of solvent (Clause 5).
- Rinse all parts first with acetone and then with hot tap water followed by several rinsings with distilled water.

- Dry the component parts thoroughly in an oven at 105°C to 110°C for no longer than 90 min. Actual drying time depends on the design of the cell but usually 60 min to 90 min is satisfactory to remove any moisture.

When a number of samples of the same type of unused liquid are to be tested consecutively, the same test cell may be used without intermediate cleaning, provided that the value of the property for the sample previously tested is better than the specified value. If the value of the last sample tested is worse than the specified value, the test cell shall be cleaned before being used for further tests.

A6. Preparation of specimens and filling the test cell

Samples should be stored and handled by following the precautions outlined in Clause 8.

Specimens of unused liquids shall be prepared, preheated and poured into the cell as described in Clauses 8 and 9. Preheating on a hot plate is permissible but the sample shall be continuously stirred to avoid local overheating.

An alternative procedure for low-viscosity hydrocarbon liquids, and particularly mineral oil, consists in filling the cool cell with an oil specimen at room temperature and placing it into the heating chamber maintained at the desired temperature. The heating rate shall allow the liquid in the cell to attain test temperature within 1 h after heating has been started.

Test cells continuously used without intermediate cleaning between tests on different samples should always be flushed with a volume of the next sample corresponding to at least three fillings of the cell.

Aged hydrocarbon oils may sometimes require special precautions to avoid further oxidation during heating or retention at a high temperature.

Information about the effect of suspended foreign matter can be obtained by testing before and after filtration through a fritted glass filter of porosity grade 4.

A7. Test voltage

Dissipation factor tests should be made with a stress in the range 0.03 kV/mm to 1 kV/mm. The actual stress shall not be so high as to cause secondary phenomena at the electrodes.

The d.c. test voltage chosen for resistivity measurements shall be such as to subject the liquid to an electrical stress of 50 V/mm to 250 V/mm.

A8. Measurement

When the liquid is not heated in the cell, the reading should be made after a standing period in the cell of 10 min to 15 min and when the temperature of the inner electrode is within $\pm 2^\circ\text{C}$ of the prescribed temperature.

If heating is carried out in the cell, the liquid should reach the test temperature within 1 h (the tolerance of 2°C still applies) and the measurement then made.

When a.c. tests are required these shall always be made before applying d.c. voltage.

A single specimen may be tested for each sample.

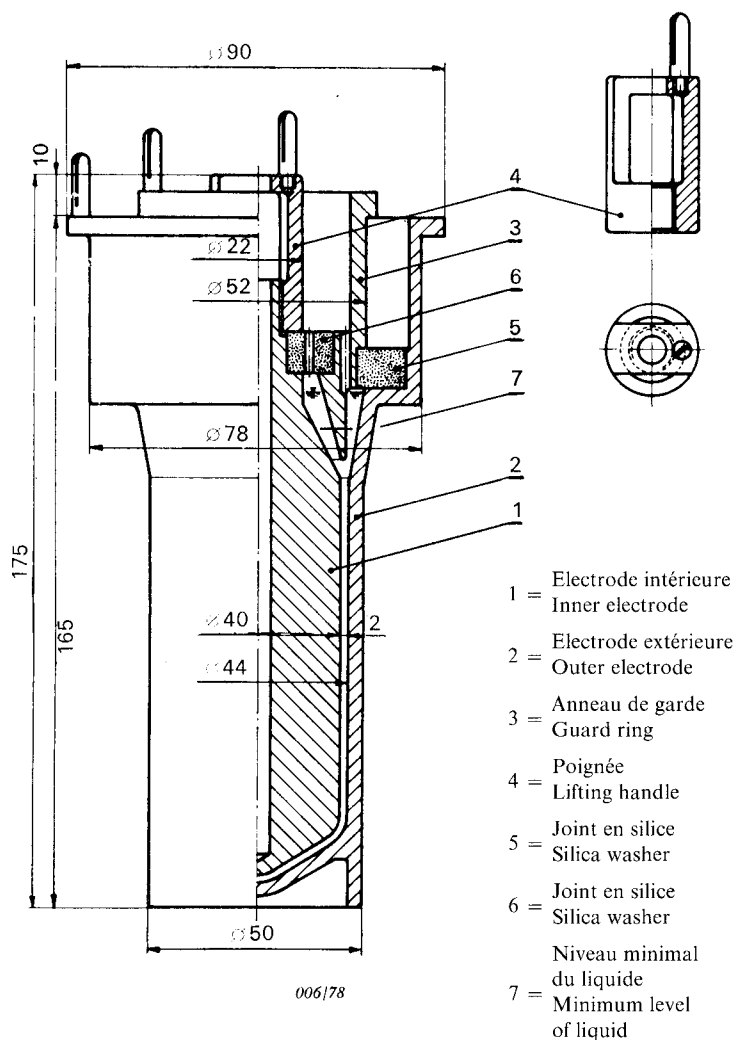

Le volume du liquide est approximativement 45 cm³
 Toutes les surfaces en contact avec le liquide doivent
 avoir un poli spéculaire

Dimensions en millimètres

Volume of liquid is approximately 45 cm³
 All surfaces in contact with liquid shall have a mirror-
 like finish

Dimensions in millimetres

FIG. 1 – Exemple d’une cellule à trois bornes pour la mesure des liquides.
 Example of a three-terminal cell for measurements on liquids.

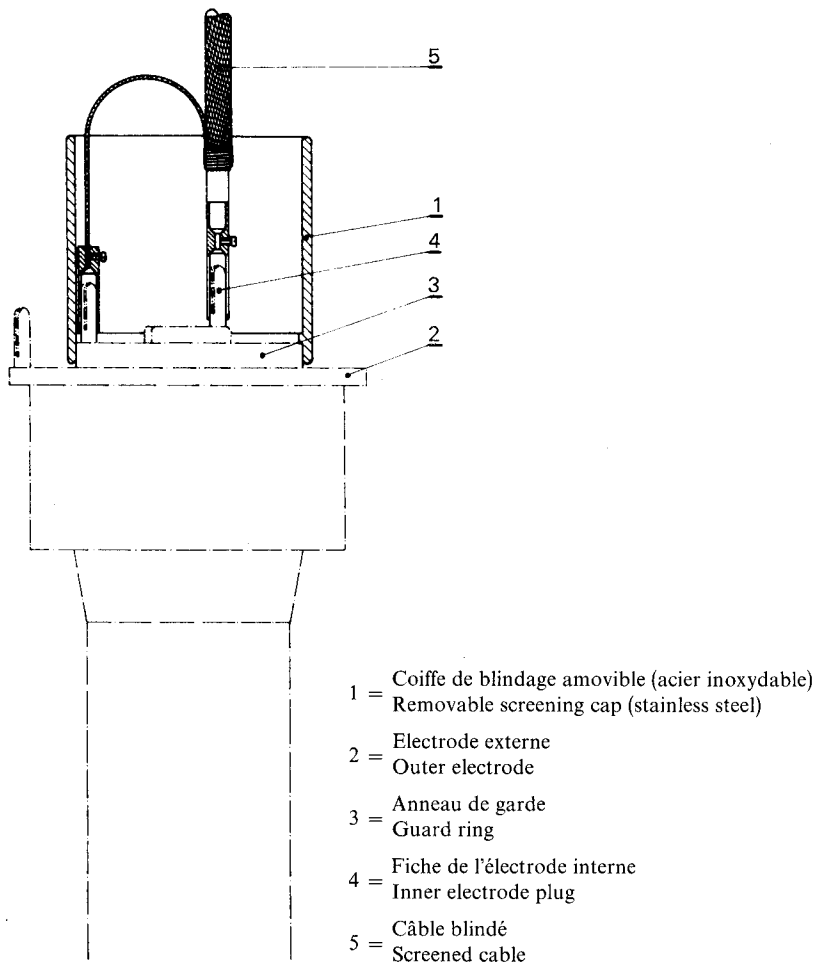

007/78

FIG. 1a – Exemple de blindage de la cellule de la figure 1.
Example of screening for the cell of Figure 1.

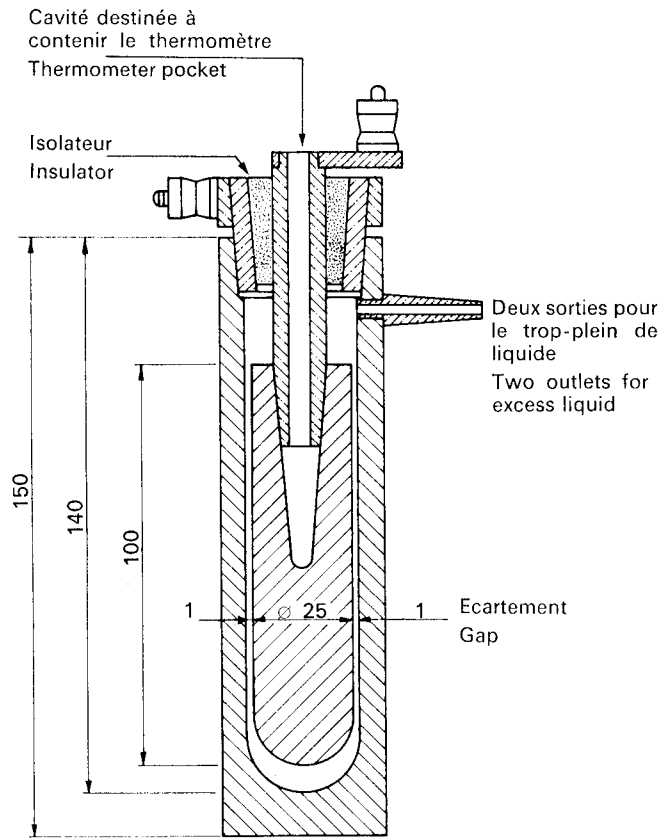

008/78

Quantité de liquide nécessaire
au remplissage de la cellule:
15 cm³ environ

Dimensions en millimètres

Quantity of liquid required to fill cell:
15 cm³ approximately

Dimensions in millimetres

FIG. 2 – Exemple d'une cellule à deux bornes pour la mesure des liquides.
Example of a two-terminal cell for measurements on liquids.

SRI LANKA STANDARDS INSTITUTION

The Sri Lanka Standards Institution (SLSI) is the National Standards Organization of Sri Lanka established under the Sri Lanka Standards Institution Act No. 6 of 1984 which repealed and replaced the Bureau of Ceylon Standards Act No. 38 of 1964. The Institution functions under the Ministry of Science & Technology.

The principal objects of the Institution as set out in the Act are to prepare standards and promote their adoption, to provide facilities for examination and testing of products, to operate a Certification Marks Scheme, to certify the quality of products meant for local consumption or exports and to promote standardization and quality control by educational, consultancy and research activity.

The Institution is financed by Government grants, and by the income from the sale of its publications and other services offered for Industry and Business Sector. Financial and administrative control is vested in a Council appointed in accordance with the provisions of the Act.

The development and formulation of National Standards is carried out by Technical Experts and representatives of other interest groups, assisted by the permanent officers of the Institution. These Technical Committees are appointed under the purview of the Sectoral Committees which in turn are appointed by the Council. The Sectoral Committees give the final Technical approval for the Draft National Standards prior to the approval by the Council of the SLSI.

All members of the Technical and Sectoral Committees render their services in an honorary capacity. In this process the Institution endeavours to ensure adequate representation of all view points.

In the International field the Institution represents Sri Lanka in the International Organization for Standardization (ISO), and participates in such fields of standardization as are of special interest to Sri Lanka.

SLS CERTIFICATION MARK

The Sri Lanka Standards Institution is the owner of the registered certification mark shown below. Beneath the mark, the number of the Sri Lanka Standard relevant to the product is indicated. This mark may be used only by those who have obtained permits under the SLS certification marks scheme. The presence of this mark on or in relation to a product conveys the assurance that they have been produced to comply with the requirements of the relevant Sri Lanka Standard under a well designed system of quality control inspection and testing operated by the manufacturer and supervised by the SLSI which includes surveillance inspection of the factory, testing of both factory and market samples.

Further particulars of the terms and conditions of the permit may be obtained from the Sri Lanka Standards Institution, 17, Victoria Place, Elvitigala Mawatha, Colombo 08.

