

SRI LANKA STANDARD 734 PART 3 : 2017
UDC 621.316

**SPECIFICATION FOR
13 A PLUGS, SOCKET-OUTLETS, ADAPTORS
AND CONNECTION UNITS
PART 3 : SPECIFICATION FOR ADAPTORS**

SRI LANKA STANDARDS INSTITUTION

Sri Lanka Standard
SPECIFICATION FOR 13 A PLUGS, SOCKET-OUTLETS,
ADAPTORS AND CONNECTION UNITS
PART 3 SPECIFICATION FOR ADAPTORS

SLS 734 Part 3: 2017
(AMD 520 Attached)

Gr. 24

Copyright Reserved
SRI LANKA STANDARDS INSTITUTION
17, Victoria Place,
Elvitigala Mawatha,
Colombo 8
Sri Lanka

Sri Lanka Standards are subject to periodical revision in order to accommodate the progress made by industry. Suggestions for improvement will be recorded and brought to the notice of the Committees to which the revisions are entrusted.

This standard does not purport to include all the necessary provisions of a contract.

© SLSI 2016

All right reserved. Unless otherwise specified, no part of this publication may be reproduced or utilized in any form or by any means, electronic or mechanical, including photocopying and microfilm, without permission in writing from the SLSI.

CONTENTS

CLAUSE	PAGE
Foreword.....	3
1 Scope	3
2 References.....	4
3 Terms and definitions.....	7
4 Conditions of use.....	11
5 General conditions for type testing.....	11
6 Classification and rating	13
7 Marking and labelling.....	13
8 Clearances, creepage distances and solid insulation	16
9 Accessibility of live parts	21
10 Provision for earthing.....	22
11 Terminals and terminations of intermediate adaptors and adaptor plugs.....	23
12 Construction of adaptors (plug portion)	26
13 Construction of adaptors (adaptor socket-outlet portion)	34
14 Resistance to ageing and to humidity	40
15 Insulation resistance and electric strength	41
16 Temperature rise.....	42
17 Breaking capacity of adaptors	45
18 Normal operation of adaptors.....	46
19 Connection of flexible cables and cable anchorage in intermediate adaptors and adaptor plugs.....	47
20 Mechanical strength.....	50
21 Screws, current-carrying parts and connections.....	52
22 Resistance to heat	53
23 Resistance to abnormal heat and fire	54
24 Resistance to excessive residual stresses and to rusting	55
25 Overload tests	56

List of Tables

Table 1	Schedule of tests	12
Table 2	Rated current and maximum fuse rating in normal use, and load for flexing and cable grip tests related to size of flexible cable.....	15
Table 3	Minimum clearances for basic insulation.....	18
Table 4	Minimum creepage distances (mm) for basic insulation	19
Table 5	Withstand voltages for insulation types	20
Table 6	Torque values for screws and nuts.....	24
Table 7	Actuator test force	39
Table 8	Permitted temperature rises.....	44
Table 9	Connection of flexible cables	50
Table 10	Application of glow-wire test	54
Table F.1	Test voltages for verifying clearances at sea level.....	107

List of Figures

Figure 1	Test pin	57
Figure 2	Apparatus for mechanical strength test on resilient covers	58
Figure 3	Hardwood block for Figure 2	59
Figure 4	Disposition of socket contacts	60
Figure 5	Dimensions and disposition of pins	61
Figure 6	Concave shrinkage allowances for ISOD	63
Figure 7	Gauge for plug pins	65
Figure 8	Apparatus for testing plug cover fixing screws	65
Figure 9	Mounting plate	66
Figure 10	Plug pin deflection test apparatus for resilient adaptors	67
Figure 11	Apparatus for abrasion test insulating sleeves of plug pins	69
Figure 12	Apparatus for Pressure test at high temperature	70
Figure 13	GO gauge for socket outlet	71
Figure 14	Contact test gauge	72
Figure 15	Test Apparatus and circuit for use with contact and non-contact gauges	73
Figure 16	Non-Contact test gauge	74
Figure 17a	Withdrawal pull gauges for effectiveness of contact: Gauge for earthing socket contact ..	75
Figure 17b	Withdrawal pull gauges for effectiveness of contact: Gauge for line and neutral current carrying socket contact	76
Figure 18	Test apparatus for temperature rise test	78
Figure 19	Dummy front plate for temperature rise test	79
Figure 20	Apparatus for flexing test	80
Figure 21	Solid link for test on fuse clips	80
Figure 22	Tumbling barrel	81
Figure 23a	Pendulum impact test: General view of apparatus	81
Figure 23b	Pendulum impact test: Constructional details of striking elements	82
Figure 23c	Pendulum impact test: Constructional details of mounting support for test samples	83
Figure 24	Apparatus for pressure test	84
Figure 25	Calibrated link	87
Figure 26	Calibration jig for calibrated link	87
Figure 27	Test plug for temperature rise	89
Figure 28a	Apparatus for tests on adaptor pins: An adaptor pin under test	91
Figure 28b	Apparatus for tests on adaptor plug pins: Details of anvils	91
Figure 29	Apparatus for torsion test on pins	92
Figure 30	Test plug	92
Figure 31	Simulated plug and cable devices	93
Figure 32	Apparatus for calibration of turning moment of simulated plug	94
Figure 33a	Turning moment apparatus: Front view and side view	95
Figure 33b	Turning moment apparatus: Top view and pictorial overview	95
Figure 34	Solid links for test on fuse clips	96

List of Annexes

Annex A	The construction and calibration of a calibrated link	97
Annex B	Measurement of clearance and creepage distances	98
Annex C	Determination of the comparative tracking index (CTI) and proof tracking index (PTI) ..	103
Annex D	Relation between rated impulse withstand voltage, rated voltage and overvoltage	104
Annex E	Pollution degree	105
Annex F	Impulse voltage test	106
Annex G	Test plug for temperature rise test	108
Annex H	Requirements for incorporated electronic components	109

Sri Lanka Standard
SPECIFICATION FOR 13 A PLUGS, SOCKET - OUTLETS,
ADAPTORS AND CONNECTION UNITS
PART 3 SPECIFICATION FOR ADAPTORS
(SECOND REVISION)

FOREWORD

This Standard was approved by the Sectoral committee on Electrical appliances and accessories and was authorized for adoption and publication as a Sri Lankan standard by the council of the Sri Lanka standards institution on 2017-02-24.

This standard is presented in five parts as given below and Part 1 and Part 2 are second revision of **SLS 734: 1996** and other parts are newly included in this standard:

Part 1: Specification for rewirable and non-rewirable 13A fused plugs

Part 2: Specification for 13A switched and unswitched socket outlets

Part 3: Specification for adaptors

Part 4: Specification for 13A fused connection units, switched and unswitched

Part 5: Specification for fused conversion plugs

This is Part 3 of the **SLS 734** and it specifies requirements for adaptors, for household, commercial and light industrial purposes, with particular reference to safety in normal use.

All values given in this specification are in SI unit.

For the purpose of deciding whether a particular requirement of this standard is complied with the final value observed or calculated, expressing the results of a test or an analysis shall be rounded off in accordance with **SLS 102**. The number of figures to be retained in the rounded off values shall be the same as that of the specified value in this standard.

In the preparation of this standard, the assistance derived from the **BS 1363** for 13 A Plugs, Socket outlets, Adaptors and Connection units, Part 3: 2016 Specification for adaptors is gratefully acknowledged.

1 SCOPE

This part of **SLS 734** specifies requirements for adaptors having insulating sleeves on the line and neutral plug pins and suitable for use with socket-outlets conforming to **SLS 734 Part 2** with particular reference to safety in normal use. Adaptors specified in this standard are intended for household, commercial and light industrial purposes. The adaptors are suitable for the connection of portable appliances, sound-vision equipment, luminaires, etc., in a.c. circuits only, operating at voltages not exceeding 250 V r.m.s. at 50 Hz. Adaptors incorporating electronic components detailed in Annex **H** are included within this part of **SLS 734**.

This standard applies only to fused adaptors.

This standard also applies to shaver adaptors which have the earth pin replaced with a similarly dimensioned protrusion made of insulating material designated as an insulated shutter opening device (ISOD) designed to operate the shutter mechanism of a socket-outlet conforming to **SLS 734 Part 2**.

Adaptors conforming to this standard are shuttered and therefore do not require the use of additional means to shield the current-carrying contacts when no plug is present in the adapter socket-outlets.

Assemblies comprising a plug and one or more portable socket-outlets connected together by a flexible cable are not considered to be adaptors according to this part of **SLS 734**. Devices incorporating, transformers, timers, thermostats or other control means are outside the scope of this part of the standard.

NOTES:

1) *In order to maintain safety and interchangeability with plugs and socket-outlets it is necessary that these products conform to the requirements 9, 12 and 13; however their body outline need not be limited at a distance of 6.35 mm from the plug engagement surface.*

2) *Attention is drawn to **BS 8546: 2016**, which covers travel adaptors.*

An adaptor is mechanical by nature of construction. The product is therefore immune from electromagnetic interference.

An adaptor that does not incorporate electronic devices does not emit intolerable electromagnetic interference since significant electromagnetic disturbances are only generated during insertion and withdrawal which are not continuous.

This standard does not cover travel adaptors.

Á

Á

2 REFERENCES

Á

IEC 60083	Standard for plugs and socket outlet for domestic and similar general use
IEC 60112	Method for the determination of the proof and the comparative tracking indices of solid insulating materials
IEC 60417	DB, Graphical symbols for use on equipment
IEC 60664	Insulation coordination for equipment within low voltage Systems- Part 1: Principles, requirements and tests Part 3: Use of coating, potting or moulding for protection against pollution Part 5: Comprehensive method for determining clearances and creepage Distances equal to or less than 2 mm

- IEC 60669 Switches for household and similar fixed electrical installations
Part 2-1: Particular requirements – Electronic switches
- IEC 60695 Fire hazard testing
Part 2- 11: Glowing hot - wire based test methods-glow- wire flammability test method for end-products(*GWEPT*)
- IEC 60695 Fire hazard testing
Part 10- 2- Abnormal heat –ball pressure test
- IEC 60893 Insulating materials – Industrial rigid laminated sheets based on thermosetting resins for electrical purposes
Part 3-4: Specifications for individual materials – Requirements for rigid laminated sheets based on phenolic resins
- IEC 60950 Information technology equipment – Safety
Part 1 – General requirement
- IEC 61000 Electromagnetic compatibility (EMC)
Part 6-1: Generic standards – Immunity for residential, commercial and light – industrial environments
Part 6-3: Emission standard for residential, commercial and light industrial Environments
- IEC 61032 Protection of persons and equipment by enclosures-probes for verification
- IEC 61051 Harmonized system of quality assessment for electric components – Varistors for use in electronic equipment
Section 2 -Specification for surge suppression varistors
- IEC 61140 Protection against electric shock – Common aspects for installation and equipment
- IEC 61180 Guide to high-voltage test techniques for low-voltage equipment
Part 1: Definitions, test and procedure requirements
- IEC 61558 Safety of transformers, reactors, power supply units and similar products for supply voltages up to 1 100V
Part 2-6: Particular requirements and tests for safety isolating transformers and power supply units incorporating safety isolating transformers
Part 2-16 Particular requirements and tests for switch mode power supply units and transformers for switch mode power supply units
- IEC 61643 Components for low voltage surge protective devices –
Part 311: Performance requirements and test circuits for gas discharge tubes (GDT)
Part 321: Specifications for avalanche breakdown diode (ABD)
Part 331: Specification for metal oxide varistors (MOV)
- IEC 62368 Audio/video, information and communication technology equipment –
Part 1: Safety requirements

IEC 62680	Universal serial Bus interfaces for data and power Part 1-1: Universal serial Bus interfaces – common components – USB Battery charging Specification, Revision 1.2 (TA 14)
BS 219	Specification for soft solders
BS 2572	Specification for phenolic laminated sheet and epoxy cotton fabric laminated sheet
BS 7211	Electric cables–Thermosetting insulated and thermoplastic sheathed cables for voltages upto and including 450/750V for electric power and lighting and having low emission of smoke and corrosive gases when affected by fire
BS 4573	Specification for two pin reversible plug and shaver socket outlet
BS 2870	Rolled copper and copper alloys – sheet, strip and foil
BS 4800	Schedule of paint colors for building purpose
BS 8546	Travel adaptors compatible with UK plug and socket system – specification
BS EN 50075	Specification for flag non-wirable two pole plugs, 2.5 A, 250 V, with cord, for the connection of Class 11 equipment for household and similar purpose
SLS 733	Electric cable- PVC insulated non – armoured cables for voltages up to and including 450/750V, for electric power, lighting and internal wiring
SLS 734	13A plugs, socket-outlets, adaptors and connection units Part 2: Specification for 13A switched and unswitched socket-outlets Part 3: Specification for adaptors Part 4: Specification for 13 A fused connection units Part 5: Specification for fused conversion plugs
SLS 948	Two-pole and earthing-pin plugs, socket-outlets and socket-outlet adaptors
SLS 963	Degrees of protection provided by enclosures (IP code)
SLS 1000	Part1: General requirements
SLS 1185	Electric cable- Single-core unsheathed heat resisting cables for voltages up to and including 450/750V, for internal wiring
SLS 1259	Sri Lankan standard voltage
SLS 1310	Boxes for flush mounting of electrical accessories
SLS 1352	Electric cables– Flexible cables rate dup to 450/750V, for use with

Appliances and equipment intended for industrial and similar environments

- SLS 1504 Electric cables – Low voltage energy cables of rated voltages upto and including 450/750V(U0/U)
 Part 1: General requirements
 Part 2-11: Cables for general applications Flexible cables with thermoplastic PVC insulation
 Part 2-12: Cables for general applications – Cables with thermoplastic PVC insulation for extensible leads
 Part2-21: Cables for general applications – Flexible cables with cross linked elastomeric insulation
 Part 2-22: Cables for general applications – High flexibility braided cables with crosslinked elastomeric insulation.
 Part 2-71: Cables for general applications – Flat tinsel cables (cords) with thermoplastic PVC insulation
- SLS 1533 Specification for general purpose fuse links for domestic and similar purposes (primarily for use in plugs)
- SLS 1552 Specification for cartridge fuse- link (rated up to 5 amperes) for a.c. and d.c service

3 TERMS AND DEFINITIONS

À

For the purposes of this part of SLS 734 the following terms and definitions apply.

NOTE: *Where the terms voltage and current are used, they imply r.m.s. values, unless otherwise stated.*

3.1 adaptor: A portable accessory having plug pins, intended to engage with the contacts of a SLS 734 socket-outlet, and having socket-outlet contacts to accommodate one or more plugs of SLS 734 Part 1.

3.2 adaptor socket-outlet: A set of contacts for forming part of an adaptor and designed to engage with the pins of a corresponding plug.

3.3 multiway adaptor : An adaptor having a plug portion and more than one set of socket portion conforming to SLS 734.

3.4 non-rewirable adaptor: An adaptor as in 3.7 or 3.8, so constructed that it forms a complete unit with the flexible cable which cannot be replaced after assembly by the manufacturer of the adaptor.

NOTE: *See also 12.6.*

3.5 rewirable adaptor: An adaptor as in 3.7 or 3.8, so constructed that a flexible cable can be fitted or replaced using general purpose tools.

3.6 fused adaptor: An adaptor having a replaceable cartridge fuse link interposed between the line pin and one or more line socket contacts.

3.7 adaptor plug: A fused adaptor having one or more socket-outlets and provision for the connection of a flexible cable to a portable appliance, in parallel with the socket-outlet.

3.8 intermediate adaptor: A fused adaptor having one or more socket-outlets and provision for the connection of a flexible cable to a remote control device in series with the socket-outlet

3.9 shaver adaptor: A fused adaptor specifically designed to have a single socket-outlet capable of accepting plugs of the following types: **BS 4573**; **BS EN 50075**, **IEC 60083**, sheet US1, NEMA 1-15

3.10 one-to-one adaptor: A fused adaptor having a plug portion conforming to **SLS 734 Part 1** and a socket portion rated for 5 A conforming to **SLS 948** and vice-versa.

3.11 shutter: A movable device arranged to shield the current-carrying socket-outlet contacts automatically when a corresponding plug is removed

3.12 terminal: A means by which the user can make an electrical connection between the appropriate flexible cable and the conducting parts of the adaptor without the use of special tools.

3.13 screw-type terminal: A terminal in which the connection is made directly by means of screws or nuts of any kind or indirectly through an intermediate metal part such as a washer, clamping plate or anti spread device on which the screw bears directly.

NOTE: *The following are examples of screw-type terminals:*

a) *A pillar terminal is a terminal in which the conductor is inserted into a hole or cavity, where it is clamped under the shank of the screw or screws.*

b) *A screw terminal is a terminal in which the conductor is clamped under the head of the screw.*

c) *A stud terminal is a terminal in which the conductor is clamped under a nut.*

3.14 termination: A means by which an electrical connection can be made between the appropriate flexible cable and the conducting part of the adaptor using special purpose tools, e.g. soldering, welding, crimping.

3.15 fuse carrier: A moveable or removable part designed to carry, retain, cover and/or remove the fuse link.

3.16 type test: A test or series of tests made on a type test sample, for the purpose of checking conformity of the design of a given product with the requirements of the relevant standard.

3.17 type test sample: A sample consisting of one or more similar units or specimens submitted by the manufacturer or responsible vendor for the purpose of a type test.

3.18 accessible external surface of an adaptor: All surfaces which can be touched by test Probe B of IEC 61032 when the adaptor is in full engagement with the corresponding socket-outlet without any plugs being in engagement with the adaptor.

3.19 engagement surface of the plug portion of an adaptor: That surface which cannot be touched by test probe B of IEC 61032 when the adaptor is in full engagement with a corresponding socket-outlet without any plugs being in engagement with the adaptor.

3.20 live parts: Current-carrying parts and those metal parts in contact with them during normal use.

NOTE: *Metal parts of the earthing circuit are not considered to be current-carrying parts.*

3.21 fine wire thermocouple: A thermocouple having wires not exceeding 0.3 mm in diameter.

3.22 calibrated link: A calibrated heat source for use in place of a fuse link during temperature rise tests.

3.23 indicator lamp (pilot lamp): A lamp or similar device which illuminates to indicate that the adaptor is energized.

3.24 resilient material: A material having the inherent capability of regaining or substantially regaining its original form when deforming loads are removed.

3.25 creepage distance: The shortest distance along the surface of the insulating material between two conductive parts.

3.26 clearance: Shortest distance in air between two conductive parts.

3.27 basic insulation: Insulation applied to live parts to provide basic protection against electric shock.

3.28 supplementary insulation: Independent insulation applied in addition to basic insulation, in order to provide protection against electric shock in the event of failure of basic insulation.

3.29 reinforced insulation: A single insulation system applied to live parts, which provide a degree of protection against electric shock equivalent to double insulation under the conditions specified in the relevant standard.

3.30 functional insulation: Insulation between conductive parts which is necessary only for the proper functioning of the equipment.

3.31 insulated shutter opening device (ISOD): Protrusion from the engagement surface of the adaptor, in place of a brass earth pin, made of insulating material having dimensions similar to those of a brass earth pin.

3.32 class I: Method of protection against electric shock which does not rely on basic insulation only, but which includes means for the connection of exposed conductive parts to a protective conductor in the fixed wiring of the installation.

3.33 class II: Method of protection against electric shock which does not rely on basic insulation only, but in which additional safety precautions, such as double insulation or reinforced insulation are provided, there being no provision for protective earthing or reliance upon installation conditions.

NOTES:

- 1) *Such a method may be one of the following.*
 - a) *Equipment having double and substantially continuous enclosure of insulation material which envelopes all metal parts with the exception of small parts such as name plates, screws and rivets which are isolated from live parts by insulation at least equivalent to reinforced insulation. Such equipment is called “insulated encased Class II equipment”.*
 - b) *Equipment having a substantially continuous enclosure of metal, in which double insulation is used throughout, except for those parts where reinforced insulation is used, such equipment is called “metal encased Class II equipment”.*
 - c) *Equipment that is a combination of types a) and b).*
- 2) *The enclosure of an insulation encased Class II appliance may form a part or whole of the supplementary insulation, or reinforced insulation.*
- 3) *If an appliance with double insulation and/or reinforced insulation throughout has an earthing terminal or an earthing contact, it is of Class I construction.*
- 4) *Class II appliances may have parts in which protection against electric shock relies on operation at safety extra-low voltage (SELV).*

3.34 engagement surface of the socket-outlet portion of an adaptor: That surface, ignoring any raised marking, which is in contact with or directly beneath the Figure 13 gauge when it is in full engagement with the socket-outlet.

NOTE: *See 13.1.*

3.35 insignificant mass: Insufficient combustible mass to constitute a fire hazard.

NOTE: *Parts of insignificant mass are usually less than 2 g.*

3.36 small parts: Parts where each surface lies completely within a circle of 15 mm diameter or where some of the surface lies outside the 15 mm diameter circle but in such a way that it is not possible to place a circle of 8 mm diameter on any of this remaining surface.

(IEC 60695-2-11 Clause 3.15)

NOTE: *More information concerning small parts can be found in IEC 60695-2-11 Clause 4.4.*

3.37 switched adaptor: An adaptor with associated switch or switches to disconnect the supply to the line socket contact or to both line and neutral socket contacts

3.38 actuating member: That part which is moved, e.g. pulled, pushed or turned by the user, to operate the switch mechanism of a switched adaptor.

NOTE: *Basic insulation does not necessarily include insulation used exclusively for functional purposes.*

4 CONDITIONS OF USE

Adaptors shall be suitable for use under the following conditions:

a) An ambient temperature in the range -5 °C to $+40\text{ °C}$, the average value over 24 h not exceeding 35 °C ;

NOTE: *Under normal conditions of use, the available cooling air is subject to natural atmospheric variations of temperature and hence the peak temperature occurs only occasionally during the hot season and on those days when it does occur it does not persist for lengthy period.*

b) situation not subject to exposure to direct radiation from the sun or other source of heat likely to raise temperatures above the limits specified in a);

c) an altitude not exceeding 2 000 m above sea level;

d) an atmosphere not subject to abnormal pollution by smoke, chemical fumes, rain spray prolonged periods of high humidity or other abnormal conditions. This is the equivalent to pollution degree 2, see Annex E, and Overvoltage Category III, see Annex D.

5 GENERAL CONDITIONS FOR TYPE TESTING

5.1 General

Adaptors shall be so designed and constructed that in normal use their performance is reliable and minimizes the risk of danger to the user or to the surroundings. Such adaptors shall be capable of meeting all the relevant requirements and tests specified in this part of the standard.

5.2 All tests shall be type tests.

Unless otherwise specified in this standard, the adaptors shall be tested as delivered by the manufacturer or responsible vendor and under normal conditions of use, at an ambient temperature of $20\text{ °C} \pm 5\text{ °C}$ after being conditioned at normal laboratory temperature and humidity levels for at least four days.

The adaptors used for the tests shall be representative of normal production items in respect of all details which may affect the test results.

Non-rewirable adaptors shall be supplied with an appropriate flexible cable which shall be at least 1 m long.

Adaptors shall be deemed to conform to this part of **SLS 734** if no sample fails in the complete series of tests given in Table 1.

TABLE 1- Schedule of tests

Sequence (1)	Sample (2)	Tests (3)	Clause number (4)
1	3	Inspection, measurement, gauging and manipulation	5, 6, 7, 9.1, 9.2, 9.3, 9.5, 9.6, 10.1, 11.1, 12.1, 12.2, 12.3, 12.4, 12.5, 12.11 (12.11.1, 12.11.2, 12.11.3 and 12.11.6 only), 12.15, 12.16, 12.17, 12.18, 13.1, 13.2, 13.3, 13.4, 13.5, 13.8, 13.9, 13.10, 19.2, 19.3, 19.4, 19.6, 8 (except Annex C and 21
2	3	General	5, 9.4, 19.1, 12.14, 12.19.2, 12.19.3, 12.19.2
3	3		5, 20.1.2, 20.1.3, 17, 13.12.1, 20.1.4, 16
4	3		5, 14.2, 12.10, 19.5, 12.19.4
5	3		5, 14.1, 20.1.5, 12.9, 10.2, 12.12, 12.6, 12.7, 12.8, 12.13
6	3		5, 14.1, 15, 13.7, 18, 13.11
7	3*		5, 12.11.4
8a)	9	Additional tests for adaptors with non-solid pins and/or an ISOD	5, 12.11.5
8b)	3	Additional tests for adaptors fitted with an ISOD	5, 12.11.4.3
9	3	Materials	5, 22
10	3		5, 23.2, 8.2 (Annex C only)
11	3		5, 24
12	3	Positive break (switched adaptors)	5, 13.12.2
13	3	Overloads	5, 14.1, 25

NOTES:

1)*denotes that an additional three samples will be required for adaptors with non-solid pins.

2) The order of tests given in sequence 1 is preferred but not obligatory except where required within the text of the appropriate clause.

If one sample fails in a complete series of tests given in Table 1, then adaptors of that type shall be deemed to have failed to conform to this part of **SLS 734**, unless the adaptor shall be shown to be not representative of normal production or design, in which case a further type test sample shall be submitted to the test or tests in that particular group. If there is no failure in this retest then adaptors of that type shall be deemed to conform to this part of **SLS 734**.

If more than one sample fails in the complete series of tests given in Table 1 the adaptors of that type shall be deemed not to conform to this part of **SLS 734**.

NOTE: For type testing, all tests have been included in the test schedule and should be performed in the specified order. References to carrying out specific tests in various clauses are not intended to indicate a sequence of testing different to that in the schedule and should not be conducted as separate additional tests.

5.2 All inspections and tests, of any one classification (see **6**), shall be carried out as specified in the clauses listed in Table 1 on the number of samples in the sample column and in the order given.

5.3 Gauges in accordance with Figure 7, Figure 13, Figure 14, Figure 16, and Figure 17a and 17b shall be considered to conform to the dimensional requirements if the measured values are within the specified dimensions and the uncertainty of measurement at not less than 95 per cent confidence level does not exceed ± 0.005 mm.

6 CLASSIFICATION AND RATING

6.1.1 Adaptors shall be classified as follows, as appropriate:

- a) Fused or unfused;
- b) Switched or unswitched;
- c) Multiway (from SLS 734 system to multiple outlets);
- d) Intermediate;
- e) Adaptor plug;
- f) Rewirable or non-rewirable (in the case of an intermediate adaptor or adaptor plug);
- g) Shaver adaptor;
- h) For shaver adaptors for Class II applications only, fitted with an un-terminated brass earth pin or ISOD.

6.1.2 The rated current of an adaptor shall be one of the following

- a) Equal to the sum of the rated currents of the adaptor socket-outlet portions, if this sum is lower than 13 A;
- b) 13 A if the sum of the rated currents of the adaptor socket-outlet portions is higher than 13 A;
- c) 13 A for an adaptor plug;
- d) 13 A if the sum of the rated currents of the socket-outlets is equal to or greater than 13 A;
- e) 5 A for one to one adaptor.

7 MARKING AND LABELLING

7.1 Adaptors shall be legibly and durably marked with the following information, which shall not be placed on screws, removable washers or other easily removable parts, or upon parts intended for separate sale:

- a) either the name, trade mark or identification mark of the manufacturer or responsible vendor, which may be duplicated on a removable fuse carrier;

- b) on rewirable adaptors, the terminals intended for the connection of the various conductors shall be identified by the symbols given in 7.5;
- 8) for fused adaptors, the words “FUSE” or “FUSED” or the symbol (given in 7.5) on the external accessible surface of the adaptor
- d) non-rewirable adaptors shall be marked on the engagement surface with the rated current of the fuse link fitted, which shall not exceed the value given in Table 2 for the appropriate size of flexible cable;
- e) adaptors other than shaver adaptors shall be marked, on the engagement surface with their total maximum electrical load intended to be connected in amperes, as calculated in 6.2, e.g. “MAX 13 A”; and “MAX 5 A” for one to one adaptors
- f) Shaver adaptors shall be marked on the accessible external surface with appropriate words, e.g. “SHAVERS ONLY”.

Shaver adaptors shall be marked on the engagement surface with appropriate words to indicate that the adaptor shall be fitted with a 1 A rated fuse conforming to **SLS 1552**.

- g) all adaptors shall be marked with:
 - 1) rated volts;
 - 2) nature of supply

7.1.1 Conformity shall be checked by inspection and by rubbing the marking for approximately 15 s with a cloth soaked in water, and again for approximately 15 s with a cloth soaked in an aliphatic solvent hexane with a content of aromatics of maximum 0.1 per cent by volume, a kauri-butanol value of 29, initial boiling point of approximately 69 °C, and relative density of approximately 0.68. The marking shall remain legible. Markings produced by an engraving or moulding process shall be deemed to conform without test.

7.2 Rewirable intermediate adaptors and adaptor plugs shall have a removable tag or label indicating the rating of the fuse link fitted, e.g. “Fitted with X ampere fuse” (where X denotes the rating of the fuse link).

7.2.1 Conformity shall be checked by inspection.

7.3 Except where an intermediate adaptor or adaptor plug fitted with a flexible cable is supplied direct to a manufacturer for incorporation in other equipment, the free end of such an assembly shall have label attached which shall include the following:

- a) the statement: “The flexible cable is this intermediate adaptor (or adaptor plug) must be connected to a piece of equipment before being plugged into a socket-outlet”;
- b) the maximum rating, in amperes, of the equipment to which it may be fitted (as given in Table 2);
- c) the colour code of the cores of the flexible cable as follows;

“IMPORTANT: Wires in the mains lead are coloured in accordance with the following code;

Green-and-yellow	Earth (if any)
Blue	Neutral
Brown	Line”;

d) If the intermediate adaptor or adaptor plug is fitted with a 2-core flexible cable, the following statement:

“This lead must not be used with equipment requiring the protection of an earth continuity conductor”.

7.3.1 Conformity shall be checked by inspection.

7.4 Rewirable adaptors and adaptor plugs shall be provided with adequate instructions for the safe connection of the appropriate flexible cables including clear instructions for the removal of insulation from the conductors.

7.4.1 Conformity shall be checked by inspection.

TABLE 2- Rated current and maximum fuse rating in normal use, and load for flexing and cable grip tests related to size of flexible cable

Flex cable nominal cross-sectional area, mm ²	Rated current ^{d)} , A	Test current ±0.4 A, A	Fuse rating, A	Load for flexing test +2%, -0%, kg	Cable grip Load +2%,-0% kg	Tests Torque ^{b)} Nm
(1)	(2)	(3)	(4)	(5)	(6)	(7)
0.5	3	3.5	3(5) ^{a)}	1	3	0.15
0.75	6	7	7(13) ^{a)}	1	3	0.2
1(0.75) ^{c)}	10	11	10(13) ^{a)}	2	3	0.25
1.25(1) ^{c)}	13	14	13	2	6	0.30
1.5	13	14	13	2	6	0.35




a) The figure in brackets indicates the fuse rating when a non-rewirable adaptor is used with certain types of appliances where the use of the higher rated fuse link is necessary because of their characteristics. Portable socket-outlets are not considered to be appliances and therefore the higher rated fuse cannot be used.

b) The recording of a measured value of torque in accordance with this table is considered to conform to this part of **SLS 734** on condition that the uncertainty of measurement at not less than 95 per cent confidence level does not exceed ±10 per cent.

c) The figure in brackets indicates the flexible cable size which may be used with a maximum flexible cable length of 2 m.

d) Non-rewirable adaptors may have a rated current appropriate to a smaller cable size than that fitted. (e.g. a non-rewirable adaptor rated at 3 A may be fitted with an 0.75 mm cable). In such cases, load and torque parameters for testing shall relate to the size of cable fitted and the test current shall relate to the rated current of the adaptor.

7.5 Symbols shall be as follows:

Amperes	A	
volts	V	
*Alternating current	d	
*direct current (d.c.)	=====	
line (adaptor/plugs)	L	
neutral	N	
*earth		(preferred) or 
supply line terminal (intermediate adaptors)	L in or L1	supply line terminal (intermediate adaptors)
load line terminal (intermediate adaptors)	L out or L2	load line terminal (intermediate adaptors)
*fuse		

NOTES:

- 1) *IEC 60417-DB* gives details of symbols marked with *.
- 2) *For the marking of the rated current and rated voltage of the adaptor, figures may be used alone. The figures for the current rating being placed before or above that of the rated voltage and separated by a line.*

If a symbol for nature of supply is used, it shall be placed next to the marking for rated current and rated voltage. Examples are as follows:

13 A 250 V d or 13/250 d or $\frac{13}{250}$ d
 or 13 A 250 V a.c. or 13/250 a.c. or $\frac{13}{250}$ a.c.

8 CLEARANCES, CREEPAGE DISTANCES AND SOLID INSULATION

Adaptors shall be constructed so that the clearances, creepage distances and solid insulation are adequate to withstand the electrical stresses taking into account the environmental influences that may occur. Clearances, creepage distances and solid insulation shall conform to the relevant requirements of **8.1**, **8.2**, **8.3** and **8.4**.

The distance between lead wires in the pinch of a neon lamp with external resistor shall be a minimum of 1 mm.

Adaptors conforming to the requirements for basic insulation shall be deemed to meet the requirements of this clause. If the manufacturer declares an insulation level exceeding basic insulation then the adaptor shall be tested accordingly.

NOTES:

- 1) *The requirements and tests are based on IEC 60664-1.*

2) *Product insulation consists of basic insulation and protective earthing as required by IEC 61140 for Class I equipment. Mechanical strength equivalent to that which would be provided by reinforced insulation as listed in IEC 61140 is achieved in SLS 734 products through specific mechanical and material tests.*

8.1 Clearances

Adaptors energized directly from the low voltage supply fall into Overvoltage Category **III**.

The clearances shall withstand the rated impulse voltage declared by the manufacturer considering the rated voltage and the Overvoltage Category as given in Annex **D** and the pollution degree declared by the manufacturer according to Annex **E**.

For the measurements, all parts which may be removed without the use of a tool are removed and moveable parts which can be assembled in different orientations are placed in the most unfavorable position.

NOTE: *Moveable parts are, for example, hexagonal nuts, the position of which cannot be controlled throughout an assembly.*

8.1.1 Clearances for basic insulation

The clearances for basic insulation shall not be less than the values given in Table **3** except as described below.

Smaller unspecified clearances (except those values marked in Table **3** with footnote “b”) may be used if the adaptor meets the impulse withstand voltage test of Annex **F** at the impulse voltage specified in Annex **D** but only if the parts are rigid or located by mouldings or if the construction is such that it is unlikely that distances will be reduced by distortion or by movement of the parts during mounting, connection and normal use.

Conformity shall be checked by inspection, and if necessary by measurement, or by the test of Annex **F**.

If clearance distances are to be measured, this shall be carried out in accordance with Annex **B**.

8.1.2 clearances for functional insulation

The clearances for functional insulation shall not be less than the values specified for basic insulation in **8.1.1**.

Conformity shall be checked by inspection, and if necessary by measurement, or by the test of Annex **F**.

If clearance distances are to be measured, this shall be carried out in accordance with Annex **B**.

8.1.3 Clearances for supplementary insulation

The clearances for supplementary insulation shall not be less than the values specified for basic insulation in **8.1.1**.

Conformity shall be checked by inspection, and if necessary by measurement, or by the test of Annex **F**.

If clearance distances are to be measured, this shall be carried out in accordance with Annex **B**.

TABLE 3- Minimum clearances for basic insulation

Rated impulse withstand Voltage kV ^{a)}	Minimum clearances in air up to 2000 m above sea level mm
0.33	0.2 ^{b)}
0.50	0.2 ^{b)}
0.80	0.2 ^{b)}
1.5	0.5
2.5	1.5
4.0	3.0
6.0	5.5

a) See Annex **D**. This voltage is:

- for functional insulation: the minimum impulse voltage expected to occur across The clearance;
- for basic insulation directly exposed to or significantly influenced by transient overvoltage from the low voltage mains: the rated impulse withstand voltage of the adaptor;
- for other basic insulation: the highest impulse voltage that can occur in the circuit.

b) Minimum clearances values are based on **IEC 60664-1**.

8.1.4 Clearances for reinforced insulation

The clearances for reinforced insulation shall be not less than the values specified for basic insulation in **8.1.1** but using the next higher step for rated impulse withstand voltage given in Table **3**.

This requirement shall not be applied to the sleeves of the adaptor plug pins.

Conformity shall be checked by inspection and by measurement, or by the test of Annex **F**.

8.1.5 Contact gap

The minimum contact gap shall be 1.2 mm when the switch is in the open position, except for electronic switches covered by Annex **H.5**.

Conformity shall be checked by measurement.

8.2 Creepage distances

The creepage distance shall be dimensioned for the voltage, which is expected to occur in normal use taking into account the pollution degree, and the material group as declared by the manufacturer.

For the measurements, all parts which may be removed without the use of a tool are removed and moveable parts which can be assembled in different orientations are placed in the most unfavourable position.

NOTES:

- 1) *Moveable parts are, for example, hexagonal nuts, the position of which cannot be controlled throughout an assembly.*
- 2) *A creepage distance cannot be less than the associated clearance.*

Creepage distances are measured in accordance with Annex B.

The relationship between material group and between comparative tracking index (CTI) values and proof tracking index (PTI) values is as follows:

Material group I	$600 \leq \text{CTI/PTI}$
Material group II	$400 \leq \text{CTI/PTI} < 600$
Material group IIIa	$175 \leq \text{CTI/PTI} < 400$
Material group IIIb	$100 \leq \text{CTI/PTI} < 175$

The CTI or PTI values are determined in accordance with Annex C.

- 3) *For glass, ceramics and other inorganic materials which do not track, creepage distances need not be greater than their associated clearance*

8.2.1 Creepage distances for basic insulation

The creepage distances for basic insulation shall not be less than the values given in Table 4. Conformity shall be checked by measurement.

TABLE 4- Minimum creepage distances (mm) for basic insulation

Rated voltage ^{a)} V (r.m.s.) Up to and including	Pollution degree 2 ^{b)} Material group			Pollution degree 3 ^{b)} Material group			
	(1)	(2)	(3)	(4)	(5)	(6)	(7)
---	I	II	IIIa/IIIb	I	II	IIIa	
250	1.3	1.8	2.5	3.2	3.6	4.0	

^{a)} This voltage is the voltage rationalized through Table F.3a and Table F.3b of IEC 60664-1 based on the nominal voltage of the supply system.

^{b)} Details of pollution degrees are given in Annex E.

8.2.2 Creepage distances for functional insulation

The creepage distance for functional insulation shall not be less than the values specified for basic insulation in 8.2.1.

Conformity shall be checked by measurement.

8.2.3 Creepage distances for supplementary insulation

The creepage distances for supplementary insulation shall not be less than the values specified for basic insulation in 8.2.1.

Conformity shall be checked by measurement.

8.2.4 Creepage distances for reinforced insulation

The creepage distances for reinforced insulation shall not be less than those derived from twice the distance specified for basic insulation in Table 4.

This requirement shall not be applied to the sleeves of the adaptor plug pins.

Á

Conformity shall be checked by measurement.

8.3 Solid insulation

Solid insulation for basic, functional, supplementary and reinforced insulation shall be capable of withstanding electrical stresses which can occur in normal use.

No minimum thickness is specified for solid insulation.

8.3.1 Conformity shall be checked by tests in accordance with 15.1.3 using the values given in Table 5.

TABLE 5 - Withstand voltages for insulation types

Insulation	Test voltage V (r.m.s.)
Functional insulation	1500
Basic insulation	1500
Supplementary insulation	1500
Reinforced insulation	3000

8.4 Requirements for printed wiring boards and equivalent construction

Printed wiring boards and equivalent construction shall conform to IEC 60664-5.

Where coating, potting or moulding is used articles shall conform to IEC 60664-3

9 ACCESSIBILITY OF LIVE PARTS

9.1 Live parts of adaptors shall not be accessible when wired as in use and in full engagement in a corresponding socket-outlet. Removal of detachable fuse carriers shall not result in live parts becoming accessible when the adaptor is in full engagement with the socket-outlet.

Additionally, adaptor plugs shall conform to this requirement without a flexible cable fitted.

9.1.1 Conformity shall be checked by the application of test probe 12 of **IEC 61032** applied with a force of 5_{-1}^0 N with non-rewirable adaptors fitted with their appropriate flexible cables, rewirable intermediate adaptors fitted with a 2-core flexible cable as given in **SLS 1504-2-71**. Detachable fuse carriers shall be removed before this test is undertaken.

9.2 Adaptors shall be so designed that when they are mounted and wired as in normal use live parts are not accessible.

9.2.1 Conformity shall be checked by the application of the test pin shown in Figure 1 perpendicular to the accessible external surface of the adaptor with a force of 5_{-1}^0 N. It shall not be possible to touch live parts.

9.3 The plug portion of an adaptor shall be designed and constructed so as to protect the user against accidental contact with live parts during insertion or withdrawal from corresponding socket-outlets. The socket-outlets of an adaptor shall be designed and constructed so as to protect the user against accidental contact with live parts during insertion or withdrawal of plugs.

9.3.1 Conformity shall be verified by satisfying the dimensional and gauging requirements of this part of **SLS 734**.

9.4 Resilient covers of adaptors shall be so designed and constructed that when assembled and wired as in normal use, there is no risk that, as a result of undue pressure, live parts could penetrate the cover or become so disposed as to reduced creepage distances and clearances below those given in **8**.

9.4.1 Conformity shall be checked by the following test (an example of a suitable apparatus is shown in Figure 2 and Figure 3).

The design of the apparatus shall be such that a steady force of 240_{FE}^0 N can be applied to those places where the possibility of a failure exists, the force being applied through a metal test pressure block as shown in Figure 2.

Each sample shall be subjected to the force at each chosen place in turn. During each application of force, a test voltage of $2\ 000\ V \pm 60\ V$, 50 Hz of substantially sinusoidal wave force is applied for 60_{+5}^0 s between all live parts bonded together and the metal pressure block.

During the test no flashover or breakdown shall occur.

After the test it shall not be possible to touch live parts with test probe 11 of **IEC 61032** applied with a force of 30_{-2}^0 N.

9.5 Except for assemblies supplied to equipment manufacturers for incorporation into their equipment, an intermediate adaptor or adaptor plug supplied fitted with a flexible cable shall have the free end of such an assembly encapsulated in insulating material.

9.5.1 Conformity shall be checked by inspection.

9.6 It shall not be possible to introduce a conducting device through the earthing socket aperture(s) of an adaptor in such a manner that there is a risk of making contact with live parts, or a live conductor with or without insulation.

9.6.1 Conformity shall be checked by introducing a rigid metal pin, $1_{-0.05}^0$ mm diameter \times 60 mm \pm 1 mm long, through any earthing socket aperture or apertures of a socket-outlet of an adaptor mounted as in normal use, applying a force of 5_{-1}^0 N, and with conductors, if any, in the most unfavorable position.

10 PROVISION FOR EARTHING

10.1 Adaptors shall be so constructed that, when inserting a plug with an earthing pin into a corresponding socket-outlet of an adaptor the earth connection is made before the current-carrying pins of the plug become live. When withdrawing a plug the current-carrying parts shall separate before the earth contact is broken.

10.1.1 Conformity shall be checked by inspection and electrical test.

10.2 All accessible metal parts of adaptors shall be in effective electrical contact with the earthing socket contact and earthing plug pin, except that metal parts on or screws in or through, non-conducting material, and separated by such material from current-carrying parts in such a way that in normal use they cannot become live, need not be in effective electrical contact with the earthing socket contact and earthing plug pin.

Metal parts having an accessible surface coating of lacquer or enamel shall be tested as accessible metal parts.

10.2.1 Conformity shall be checked by inspection, and the following:

- a) for metal parts insulated from live parts, by the test described in **15.1.3**;
- b) for metal parts connected to an earthing terminal or earthing plug pin, by the following test.

A current of 25 A \pm 0.75 A, derived from an a.c. source having a no-load voltage not exceeding 12 V, is passed for 60_{-0}^{+5} s as follows:

1) for all adaptors, between the earthing pin of the adaptor, and the following:

- i) the terminal of an earthing pin of an appropriate plug inserted into each adaptor earthing socket contact;
- ii) any accessible metal part intended to be earthed;

- 2) for intermediate adaptors and adaptor plugs, between the earthing terminal, and the following:
- i) the remote end of an earthing pin of an adaptor;
 - ii) any accessible metal part intended to be earthed.

The resistance between the earthing plug pin or earthing terminal and any other nominated part shall not exceed 0.05 Ω .

11 TERMINALS AND TERMINATIONS OF INTERMEDIATE ADAPTORS AND ADAPTOR PLUGS

11.1 Terminals and terminations shall provide for effective clamping and securing of conductors connected to them, so that efficient electrical connection is made.

11.1.1 Conformity shall be checked in accordance with **11.2** to **11.9**.

11.2 Rewirable adaptors shall be provided with terminals as defined in **3.12** or **3.13**.

11.2.1 Conformity shall be checked by inspection.

11.3 Non-rewirable adaptors shall be provided with soldered, welded, crimped or similar terminations. For all these methods of termination, not more than one strand of a 0.5 mm² conductor or two strands of other sized conductors shall be fractured during connection. Screwed and 'snap-on' terminals shall not be used. Crimped connections shall not be made on to pre-soldered flexible cables unless the soldered area is entirely outside the crimp.

11.3.1 Conformity shall be checked by inspection and measurement.

11.4 Terminals in rewirable adaptors shall permit the connection, without special preparation, of flexible cables having nominal conductor cross-sectional area as of 0.5 mm² to 1.5 mm².

11.4.1 Conformity shall be checked by inspection and fitting the appropriate conductors.

11.5 Where pillar terminals are used they shall have clamping screws of sufficient length to extend to the far side of the conductor hole. The end of the screw shall be slightly rounded so as to minimize damage to the conductors. The sizes of the conductor hole and the clamping screw shall be such that the clearance between each side of the major diameter of the clamping screw and the conductor hole does not exceed 0.4 mm.

11.5.1 Conformity shall be checked by inspection and measurement.

11.6 Terminal screws shall have a declared outside diameter of not less than 3 mm or be not smaller than 6 B.A.

Thread cutting and/or thread forming screws shall not be used.

11.6.1 Conformity shall be checked by inspection and measurement.

11.7 Insulating barriers in intermediate adaptors or adaptor plugs shall be an integral part, so arranged that with the cable anchorage rendered inoperative and the earth or line conductors becoming detached from their respective terminals, there is negligible risk of the following:

- a) the earth conductor coming into contact with parts at line potential;
- b) the line conductor in a fused adaptor coming into contact with the line pin assembly.

11.7.1 Conformity shall be checked by inspection and, except for non-rewirable adaptors, by the following test.

Rewirable adaptors are wired as in normal use with an appropriate 0.5 mm² 3-core flexible cable as given in **SLS 1504-2-11** in accordance with the manufacturer's instructions. All terminal screws or nuts are tightened to the appropriate torque given in Table 6.

TABLE 6 - Torque values for screws and nuts

Declared diameter of screw thread mm	Torque (see Note 1) For metal screws (see Note 2) Nm	For other metal screws and nuts Nm	For screws of insulating material Nm
(1)	(2)	(3)	(4)
Up to and including 2.8	0.2	0.4	0.4
Over 2.8 up to and including 3	0.25	0.5	0.5
Over 3.0 up to and including 3.2	0.3	0.6	0.6
Over 3.2 up to and including 3.6	0.4	0.8	0.6
Over 3.6 up to and including 4.1	0.7	1.2	0.6
Over 4.1 up to and including 4.7	0.8	1.8	0.9
Over 4.7 up to and including 5.3	0.8	2.0	1.0
Over 5.3 up to and including 6	-	2.5	1.25

NOTES:

1) The recording of a measured value given in this table is considered to conform to this part of **SLS 734** on condition that the uncertainty of measurement at not less than 95 per cent confidence level does not exceed ± 10 per cent.

2) This column applies to metal screws without heads if the screw when tightened does not protrude from the hole, and to other metal screws which cannot be tightened by means of a screwdriver with blade wider than the diameter of the screw.

A continuity indicating circuit operating at not less than 40 V shall be connected between the conductors and the other parts nominated. All terminal screws shall then be loosened and the cable anchorage rendered inoperative and the cover of the adaptor refitted. The flexible cable shall then be withdrawn from the adaptor at a rate not exceeding

50 mm/min, the direction of the pull being varied, until the earth core is pulled free of the adaptor. The test is made six times in all. For each new test, a fresh section of the cable is fitted and the flexible cable rotated through approximately 60° in the plane perpendicular to its major axis in a clockwise direction before fitting, unless the design is such that this is not practicable.

There shall be no contact between parts at line potential and the earth conductor, or between the line conductor and line pin assembly, thus bypassing the fuse link.

11.8 Intermediate adaptors or adaptor plugs shall be designed so that they can be wired in a manner which prevents strain to the earth connection before the line and/or neutral connection when the cable anchorage is rendered inoperative.

11.8.1 Conformity shall be checked by inspection and manipulation using an intermediate adaptor or adaptor plug wired in accordance with the manufacturer's instructions.

11.9 Terminals of intermediate adaptors or adaptor plugs shall be so located or shielded that if a strand of a flexible conductor escapes when the conductors are fitted, there is negligible risk of accidental connection between live parts and accessible external surfaces, or of a stray strand bypassing the fuse link.

11.9.1 Conformity shall be checked by inspection, and by the following test.

A length of insulation in accordance with the manufacturer's instructions removed from the end of a flexible conductor having a nominal cross-sectional area of 1.5 mm². One strand of the flexible conductor is left free and the other strands are fully inserted into and clamped in the terminal. The free strand is bent without tearing the insulation back, in every possible direction, but without making sharp bends round barriers unless a bend is reproduced by the replacement of the cover.

The free strand of a conductor connected to a live terminal shall not:

- a) touch any metal part so as to bypass the fuse link;
- b) touch any metal part which is accessible or is connected to an accessible metal part;
- c) reduce creepage distance and clearance to accessible surfaces to less than 1.3 mm.

The free strand of a conductor connected to an earthing terminal shall not touch any live parts.

12 CONSTRUCTION OF ADAPTORS (PLUG PORTION)

12.1 The disposition of the adaptor plug pins (including ISODs where applicable) shall be as shown in Figure 5).

12.1.1 Conformity shall be checked by inspection.

12.2 The outline of the adaptor shall not exceed the dimensions shown in Figure 5 for a distance of not less than 6.35 mm from the engagement surface and within these dimensions there shall be no axial projection from the engagement surface of the adaptor, except that at a distance more than 6.35 mm from the engagement surface the outline of the adaptor plug can exceed the dimensions shown in Figure 5 in the plane of the earth pin and in the plane of the cable entry to facilitate the removal of the adaptor from the socket.

Pin disposition, length and body outline shall be checked by use of the gauge shown in Figure 5 in accordance with the following test. Pin and sleeve dimensions shall be checked by measurement and shall conform to Figure 5, except for non-solid pins and ISOD where the chamfers shall generally fall within the profiles of Figure 5 and their adequacy shall be checked by the tests of 12.11.5. ISODs shall be of generally rectangular cross-section. "T" sections are not permitted although castellated cross-sections are permitted provided their dimensions conform to Figure 6 and all the other requirements of the standard are met.

The maintenance of these dimensions shall not rely on the terminal screws.

Adaptors fitted with an ISOD shall conform to all the dimensions specified in Figure 5 with the exception of the ISOD width which shall be 4.05 mm maximum and 3.90 mm minimum and its height which shall be 8.05 mm maximum and 7.75 mm minimum.

12.2.1 Conformity shall be checked by inspection, measurement and by the use of the gauge shown in Figure 7.

In the case of adaptors with ISODs, where alignment cannot be maintained due to the flexibility of plastic materials, the test given in 13.8 of SLS 734-2 shall be applied and the maximum withdrawal forces from a socket-outlet conforming to SLS 734 shall not exceed 36 N.

For the gauging test, intermediate adaptors and adaptor plugs shall be fitted with a 3-core 1.5 mm² flexible cable as given in SLS 1504-2-11. Non-rewirable intermediate adaptors and adaptor plugs shall be tested as delivered.

With the gauge in an approximately vertical position and the engagement surfaces of the adaptor and the gauge parallel to each other, the line and neutral pins shall be entered into the gauge for a distance not exceeding 2 mm. The adaptor shall then enter the gauge fully when a force of 10 N or less is applied to the centre of the adaptor at right angles to the engagement surface and without any additional force being applied to the pins to bring them into alignment.

12.3 No part of a line or neutral pin shall be less than 9.5 mm from the periphery of the adaptor measured along the engagement surface.

12.3.1 Conformity shall be checked by measurement.

12.4 The provision of fuses in adaptors shall be in accordance with the following.

- a) One to one adaptor shall be provided with a 5 A fuse link conforming to **SLS1552**.
- b) A multiway adaptor having the plug portion conforming to **SLS 734 Part 1** and having more than one socket-outlet conforming to **SLS 734 Part 2** shall be provided with a 13 A fuse link conforming to **SLS 1533**.
- c) An adaptor plug or an intermediate adaptor shall be provided with an appropriate fuse link, conforming to **SLS 1533** or **SLS 1552** to protect the outgoing flexible cable.
- d) A shaver adaptor shall be provided with a 1 A fuse link conforming to **SLS 1552**.

When a fuse link is provided within the body of the adaptor it shall be mounted in appropriate contacts only between the line plug pin and the corresponding line socket contact(s) in such a way that it cannot be displaced when the adaptor is in use. The design shall be such that the fuse link cannot be left in inadequate contact when the fuse cover or fuse carrier is replaced and firmly secured in position. It shall be impossible to replace the fuse link in an adaptor unless the adaptor is completely withdrawn from the socket-outlet.

12.4.1 Conformity shall be checked by inspection.

12.5 In non-rewirable intermediate adaptors and adaptor plugs, where the fuse link is retained by means of a fuse carrier, this device shall be either:

- a) Non-detachable during normal replacement of the fuse link; or
- b) readily identifiable in relation to its adaptor by means of marking.

12.5.1 Conformity shall be checked by inspection.

12.6 The base and cover of non-rewirable intermediate adaptors and adaptor plugs shall be permanently attached to each other, such that the flexible cable cannot be separated without making the adaptor permanently useless, and the adaptor cannot be opened by hand or by using a general purpose tool, for example a screwdriver used as such. An adaptor shall be considered to be permanently useless when, for reassembling the adaptor, parts or materials other than the original have to be used.

12.6.1 Conformity shall be checked by inspection and for non-moulded-on non-rewirable intermediate adaptors and adaptor plugs by the test given in **12.8.1**.

12.7 The base and cover of rewirable intermediate adaptors and adaptor plugs having the cover fixed by screws shall be firmly secured to each other. It shall not be possible to remove the cover unless the adaptor is completely withdrawn from the socket-outlet. Fixing screws shall be captive.

12.7.1 Conformity shall be checked by inspection and by the following test. Each adaptor cover fixing screw has a pull of 60^{0}_{-2} N exerted on it for 60^{+5}_{0} s whilst the surface temperature of the product is $70^{\circ}\text{C} \pm 5^{\circ}\text{C}$. The test is carried out using apparatus similar to that shown in Figure 8 and for the test the adaptor cover and apparatus are placed in an oven until they reach the required temperature.

At the end of the test, any screw thread shall be serviceable and any insert shall not have moved to such an extent that correct assembly of the adaptor is prevented.

12.8 The base and cover of adaptors other than those described in 12.6 and 12.7 shall be firmly secured to each other. It shall not be possible to remove the cover unless the adaptor is completely withdrawn from the socket-outlet.

12.8.1 Conformity shall be checked by inspection and the following test.

All the adaptor pins are clamped together in a suitable jig and subjected to a pull of 60^{0}_{-2} N whilst suspending the cover by means of a 'nest' to suit the adaptor cover profile. The test is carried out in an oven at a temperature of $70^{\circ}\text{C} \pm 5^{\circ}\text{C}$ and the pull applied for 60^{+5}_{0} s after the temperature has been attained.

After the test it shall not be possible to touch live parts with the test pin shown in Figure 1 applied with a force of 5^{0}_{-1} N.

12.8.2 Non-moulded-on, non-rewirable adaptors are tested with the flexible cable supplied. The adaptor plug pins are clamped in the vertical position using a suitable jig with the plug pins uppermost. The plug flexible cable shall be 1 m in length and a weight of $3^{0}_{+0.06}$ kg fixed to the end. With the weight initially held $0.5\text{ m} \pm 0.05\text{ m}$ from the end of the cable anchorage, and at the same height, the weight is allowed to fall through an arc of 1 m. This test shall be carried out five times.

After this test the adaptor cover shall be in place and show no damage.

Conformity shall be checked by inspection.

12.9 Adaptors shall be so designed and constructed that they cannot readily be deformed to allow access to live parts.

12.9.1 Conformity shall be checked by inspection and by the following test.

Immediately after the test described in 16, test probe 11 of IEC 61032 is applied to the accessible surface of the adaptor with a force of 30^{0}_{-5} N. It shall not be possible to touch live parts.

12.10 For non-rewirable intermediate adaptors and adaptor plugs means shall be provided to prevent loose strands of a conductor or current-carrying parts from reducing the minimum insulation thickness requirements between such parts and all accessible external surfaces of the adaptor.

12.10.1 Conformity shall be checked by inspection and by the test described in 15.2.

12.11 Materials other than brass shall not be used in the construction of line and neutral adaptor plug pins except for sleeves of pins as specified in 12.18. Adaptor plug pins and ISODs shall conform to 12.11.1. Non-solid pins shall conform to 12.11.2.

12.11.1 All exposed surfaces of the adaptor plug pins shall be smooth and free from burrs or sharp edges and other irregularities which could cause damage or excessive wear to corresponding socket contacts or shutters.

12.11.1.1 Conformity shall be checked by inspection.

12.11.2 Those surfaces of the non-solid adaptor plug pins which are visible when the adaptor is correctly assembled shall be free of apertures.

12.11.2.1 Conformity shall be checked by inspection.

12.11.3 All seams and joints of non-solid adaptor plug pins shall be closed over their entire length.

12.11.3.1 Conformity shall be checked by inspection and in case of doubt by the following test.

Push a steel test probe of 0.2 mm diameter into all seams and joints. Check that the test probe does not enter into any seam or joint to a depth greater than the thickness of the material from which the plug pin is formed.

12.11.4 Adaptor plug pins and ISODs shall have adequate strength to withstand the stresses of normal use.

Á

12.11.4.1 For solid pins conformity shall be checked by the following test.

Á

Position a pin on the fixed anvil of the apparatus, as shown in Figure **28a**) and Figure **28b**), with its contact surfaces in the horizontal plane. Apply a force of 1100_{-10}^0 N to the movable anvil by any convenient method such that the pin is strained at a rate not exceeding 10 mm/min. The test shall be made separately on the line, neutral and earth pins applying load perpendicular to the major axis surfaces of the pins. After this test the adaptor shall fit the gauge shown in Figure **7** when used in the manner described in **12.2.1**.

12.11.4.2 For non-solid pins, conformity shall be checked by the following tests.

a) Position a pin on the fixed anvil of the apparatus, as shown in Figure **28a**) and Figure **28b**), with its contact surfaces in the horizontal plane. Bring the movable anvil to rest against the upper surface of the pin. Apply a force of 800_{-10}^0 N moveable anvil 50 times without impact.

The test shall be made separately on the line, neutral and earth pins applying the load perpendicular to the major axis surfaces of the pins. If there is a joint or seam in one of the major axis surfaces of a pin then the test shall be made twice. The seam or joint shall face the moving anvil for the first test and shall face the fixed anvil for the second test.

After the test the pins shall conform to **12.11.2** and **12.11.3** and the adaptor shall fit the gauge shown in Figure **7** when used in the manner described in **12.2.1**.

b) Separate samples shall be used for the following test.

Position a pin on the fixed anvil of the apparatus, as shown in Figure **28a)** and Figure **28b)**, with the widest surface in the horizontal plane. Bring the movable anvil to rest against the upper surface of the pin. This quiescent position shall be taken as the datum point. Apply a force to the movable anvil by any convenient method such that the pin is strained at a rate not exceeding 10 mm/min. Measure the applied force when the movement of the anvil from the datum point reaches $1.5^{+0}_{-0.1}$ min. The test shall be made separately on the line, neutral and earth pins applying the load perpendicular to the major axis surfaces of the pins. If there is a joint or seam in one of the major axis surfaces of a pin then the test shall be made twice. The seam or joint shall face the moving anvil for the test and shall face the fixed anvil for the second test. The force shall be not less than 1 100 N.

12.11.4.3 For ISODs, conformity shall be checked by the following test.

Position the ISOD on the fixed anvil of the apparatus as shown in Figure **28a)** and Figure **28b)** with the widest surface in the horizontal plane. Bring the moveable anvil to rest against the upper surface of the ISOD. The quiescent position shall be taken as the datum point. Apply a force to the moveable anvil by any convenient method such that the ISOD is strained at a rate of 10 ± 2 mm/min.

A force of 400^{+10}_0 N is applied and the measured deflection shall not exceed 1.5 mm. The ISOD shall not be broken or show cracks that are visible with normal or corrected vision without additional magnification.

After the test the adaptor plug pins shall fit the Figure 7 gauge when used in the manner described in **12.2.1** with a force not exceeding 20 N.

When testing an adaptor fitted with an ISOD due to the flexibility of plastic materials some additional alignment of the ISOD is allowed when inserting into the Figure 7 gauge. Where alignment cannot be maintained, the test of **13.8** of **SLS 734 Part 2** shall be applied and the maximum withdrawals force from a socket-outlet conforming to **SLS 734 Part 2** shall not exceed 36 N.

12.11.5 Adaptors with non-solid pins and/or ISODs shall not cause excessive wear to socket contacts or shutters of socket-outlets in accordance with **SLS 734 Part 2**. For adaptors with non-solid pins, conformity shall be checked by **12.11.5.1**. For adaptors with ISODs, conformity shall be checked by **12.11.5.2**.

12.11.5.1 Conformity shall be checked by the following tests.

The test is carried out with adaptors with non-solid pins and three different types of new socket-outlets in accordance with **SLS 734 Part 2**. Two types of the socket-outlet shall have the shutters operated by the earth pin, one of which is preferably operated by all three pins and one of which is preferably operated by live and neutral pins only.

The combination of rewirable adaptors having non-solid pins and each type of socket-outlet as described shall make and break a current of $13 \text{ A} \pm 0.4 \text{ A}$, non-rewirable adaptors shall be tested with the rated current appropriate to the flexible cable given in Table 2, at $250 \text{ V} \pm 10 \text{ V}$ a.c. 15000 times (30 000 movements) in a substantially non-inductive circuit.

Each adaptor is inserted into and withdrawn from the socket-outlet at a rate of six insertions and six withdrawals per minute, the speed of travel of the adaptor being approximately 150 mm/s. The period during which the adaptor is inserted and withdrawn shall be approximately equal. The adaptor pins are renewed or a new adaptor is used after each 5000 insertions and withdrawals. For the purpose of this test, no lubrication is applied to the pins of the adaptor or the socket-outlet contacts.

After the test the shutters of the socket-outlets shall be operating satisfactorily, the socket contacts shall be safely shielded and the socket-outlets shall be in accordance with **9.1, 16, 15, 13.4.1a), 10.2, 13.6, 13.7, and 13.8 of SLS 734 Part 2**, with the permitted values of voltage drop specified in **12.4.1a)** of **SLS 734 Part 2** for the adaptor pin to socket contact measurements increased by 50 per cent. The pins of the adaptor shall remain intact with no openings in the surface, joints or seams which will accept the probe specified in **12.11.3**.

12.11.5.2 Conformity shall be checked by the following.

Using a selection of three different makes of rewirable plugs conforming to **SLS 734A Part 1** and three different makes of unswitched socket-outlets conforming to **SLS 734A Part 2**, selected to represent different earth contact designs, the earth resistance between the earthing adaptor plug pin and the earthing socket contact of the socket-outlets shall be established in accordance with **SLS 734A Part 2, 10.2.1b)**.

All socket-outlets shall be of the type where the earth pin or ISOD of an adaptor inserted into the socket-outlet operates the shutter mechanism.

The test shall be made using a separate sample of adaptor plug with ISOD for each type of socket-outlet, with each sample being inserted into and withdrawn from the socket-outlet at a rate of six insertions and six withdrawals per minute, the speed of travel of the adaptor plug being approximately equal. For the purpose of this test no lubrication is applied to the adaptor plug pins or socket-outlet contacts either prior to or during the test.

After 5000 insertions and withdrawals, the standard rewirable adaptor used prior to the test for each type of socket-outlet shall be reinserted and the earth resistance test repeated. After the test the earth resistance between the earthing adaptor plug pin and the earthing socket contact of the socket-outlets shall be in accordance with **SLS 734 Part 2, 10.2.1b)**. The socket-outlet shall be examined and shall show no sign of damage that would impair further use. The adaptors under test shall show no damage and shall conform to the dimensional requirements of this standard.

After the test, the shutters of the socket-outlet shall operate satisfactorily and the socket contacts shall be safely shielded.

12.11.6 Adaptor plug pins and ISODs (if any) shall have adequate mechanical strength to ensure that they cannot be distorted by twisting.

12.11.6.1 Conformity shall be checked by inspection and by the following test.

The adaptor is clamped in a block as shown in Figure 29. Each pin is twisted about its longitudinal axis by applying a torque of 1 Nm \pm 10 per cent for 60⁺⁵ s. The torque tube and its position on the plug pin shall be as shown in Figure 29. After each pin has been separately twisted the adaptor shall fit the gauge shown in Figure 7. The test shall then be repeated with each adaptor plug pin being twisted in the opposite direction to that of the first test. After this second test the adaptor shall fit the gauge shown in Figure 7. In each case the gauge is used in the manner as described in 12.2.1.

12.12 The socket contacts and any terminals or terminations shall be formed as one piece with or shall be permanently connected to the pin in such a way that efficient electrical connection is made that cannot work loose in use. This connection shall not be made by means of a screw.

The contact for the fuse link, if any, shall be connected to the line socket contact and any line terminal or termination shall be formed in one piece with the socket contact and the fixed part of any terminal or termination. Alternatively, it shall be permanently connected in such a way that efficient electrical connection is made that cannot work loose in normal use, and the other contact for the fuse link shall be similarly connected to the corresponding adaptor plug pin. These connections shall not be made by means of screws.

12.12.1 Conformity shall be checked by inspection and the tests described in 20.1.5 and 16.

12.13 Adaptors shall be so designed that when fully assembled the pins are adequately retained in position such that there is no likelihood of them becoming detached from the adaptor during normal use.

12.13.1 Conformity shall be checked by the following test.

After the tests described in 20, each pin is subjected for 60⁺⁵ s to a pull of 100₋₂⁰ N in one smooth and continuous movement in the direction of the major axis. The adaptor is mounted using the steel plate shown in Figure 7. The apparatus is placed within an oven and the pull is applied at least 1 h after the adaptor body has attained the test temperature of 70 °C \pm 5 °C while maintained at this temperature.

After the test the adaptor pin shall fit the gauge shown in Figure 7 when used in the manner as described in 12.2.1.

12.14 The degree of flexibility of mounting of the adaptor plug pins or the angular movement of the pins in the base shall be not greater than 3° 30' in the directions shown in Figure 8 from an axis which is perpendicular to the plug engagement surface when the pins are subjected to a force as shown in Figure 10.

12.14.1 Conformity shall be checked by inspection and in case of doubt by the following test.

NOTE: *Adaptors may be checked using an apparatus similar to that shown in Figure 10. (Other methods of measuring the 3° 30' deflection may be used.)*

The adaptor is clamped in the mounting block by means of any two of the adaptor plug pins in such a manner as to ensure that the engagement surface of the adaptor, from which the adaptor plug pins project, is supported and in contact with the corresponding flat surface of the mounting block. The back of the adaptor is not supported and does not come into contact with the fixture. The axis of the clamped pins is horizontal.

The unclamped pin shall be tested for declination from the horizontal by applying a force of $4.4^{0}_{-0.2}$ N, $25^{0}_{-0.5}$ mm from the engagement surface of the adaptor and parallel with it in the four directions shown in Figure 10. The test shall be repeated in turn on the other two pins of the adaptor.

During each test the declination from the horizontal measured on the scale shall not exceed $3^{\circ} 30'$. After all tests have been completed the adaptor shall fit the gauge shown in Figure 7 when used in the manner as described in 12.2.1.

12.15 Suitable means shall be provided for withdrawing the intermediate adaptor or adaptor plug without subjecting the flexible cable to stress.

12.15.1 Conformity shall be checked by inspection.

12.16 Non-rewirable intermediate adaptors and adaptor plugs shall be fitted with flexible cables in accordance with 19.4.

12.16.1 Conformity shall be checked by inspection.

12.17 Conductive component parts of adaptors shall be so located and separated that, in normal use, they cannot be displaced so as to affect adversely the safety or proper operation of the adaptor.

12.17.1 Conformity shall be checked by inspection and manual manipulations.

12.18 Line and neutral adaptor plug pins shall be fitted with insulating sleeves. The dimensions of the pin and sleeve shall fall within those given in Figure 5. Sleeves shall not be fitted to any earthing adaptor plug pin.

12.18.1 Conformity shall be checked by inspection and by measurement for pin and sleeve and use of the gauge shown in Figure 7 as described in 12.2.1 for socket-outlet compatibility.

12.19 Adaptor plug pin sleeves shall have adequate electric strength, resistance to abrasion and resistance to deformation due to overheating of pins.

12.19.1 Conformity shall be checked by the tests given in 12.19.2, 12.19.3 and 12.19.4.

12.19.2 A 50 Hz voltage of substantially sinusoidal waveform is applied between each L and N pin and a thin metal strip of between 5.5 mm and 6 mm width wrapped around the base of the adaptor plug pin sleeve adjacent to the base of the adaptor. Initially not more than 500 V is applied, the voltage then being raised to $1\ 250\text{ V} \pm 30\text{ V}$ which is maintained for 60^{+5}_0 s.

During the test no breakdown or flashover shall occur.

12.19.3 The test apparatus for resistance to abrasion (see Figure 11) comprises a horizontally disposed beam pivoted about its centre point. A short length of steel wire, 1 mm \pm 0.02 mm in diameter and bent into a 'U' shape, the base of the 'U' being straight, with no surface defects, is rigidly attached at both ends to one end of the beam so that the straight part of the wire projects below the beam and is parallel to the axis of the beam pivot.

The adaptor is held in a suitable clamp as shown in Figure 11 in such a position that the straight part of the steel wire rests upon the adaptor plug pin at right angles to it and the adaptor plug pin slopes downward at an angle between 5° and 10° to the horizontal. The beam is loaded so that the wire exerts a force of 4⁰_{-0.1} N on the pin.

The adaptor is moved backwards and forwards in a horizontal direction in the plane of the axis of the beam so that the wire rubs along the pin. The length of the pin abrasion is approximately 9 mm, of which approximately 7 mm is over the insulating sleeve.

The adaptor is moved 10 000 times in each direction (20 000 movements) at a rate of 25 to 30 movements per minute.

The test shall be made on one pin of each adaptor.

After the test the sleeve shall show no damage which might impair the further use of the adaptor. The sleeve shall not have been penetrated or creased and shall satisfy the tests described in 12.19.2, any abraded brass contamination on the sleeve having been removed.

12.19.4 A set of three sample pins are tested by means of the apparatus shown in Figure 12 which has a blade 0.70^{0+0.05} mm wide and a radius of 3 mm \pm 0.1 mm. The test is made on one pin of each adaptor not used for the test described in 12.19.3.

A sample is positioned as shown in Figure 12 and the apparatus is loaded so that the blade exerts a force of 2.5⁰_{-0.1} N on the sample. The apparatus, complete with sample, is placed in a heating cabinet at 200⁰₋₈ °C for a period of 120⁰₋₅ min, after which the sample is removed and immediately cooled by immersion in water at approximately room temperature.

The thickness of the insulation remaining at the point of impression is measured and shall not have been reduced by more than 50 per cent.

13 CONSTRUCTION OF ADAPTORS (ADAPTOR SOCKET-OUTLET PORTION)

13.1 For adaptors with adaptor socket-outlets for SLS 734 plugs, the disposition of the socket contacts shall be as shown in Figure 4.

There shall be no projection on the engagement surface of the adaptor such as shall prevent the full insertion of an appropriate plug. The spacing of the socket contacts shall correspond with that of the plug pins as specified in SLS 734 Part 1.

13.1.1 Conformity shall be checked by inspection and the use of the gauge shown in Figure 13.

If raised marking is used, it shall not project more than 0.5 mm from the engagement surface and shall allow conformity with 13.2.

13.2 For adaptors with adaptor socket-outlets for **SLS 734** plugs the line and neutral socket contacts in adaptors shall be positioned so as to make satisfactory contact with the corresponding pins of a plug in all positions that the contact may occupy when the plug is correctly and fully inserted.

13.2.1 Conformity shall be checked by inspection and the use of the gauge shown in Figure 14 and the circuit shown in Figure 15. Both indicator lamps shall light.

13.3 For adaptors with adaptor socket-outlets for **SLS 734** plugs, on insertion of a plug into an adaptor, the travel of the end of either current-carrying pin from the front face of the adaptor to the first point of contact with the appropriate socket contact, in any position the socket contacts may occupy, shall be not less than 9.6 mm.

13.3.1 Conformity shall be checked by inspection and the use of the gauge shown in Figure 14 and the circuit shown in Figure 15. Neither indicator shall light.

13.4 For adaptor socket-outlets intended to accept 5 A plugs conforming to **SLS 948**, the disposition and dimensions shall enable reliable and safe interconnection and there shall be no projection on the engagement surface of the adaptor such as would prevent the full insertion of a plug. The spacing of the socket contacts shall correspond with that of the plug pins.

Raised marking is permitted provided it does not project more than 0.5 mm from the engagement face.

NOTE: *Apertures may be shaped at their front edges to facilitate insertion of plugs.*

13.4.1 Conformity shall be checked by inspection and measurement and the requirements in the appropriate standards.

13.5 Socket contacts of adaptors shall be self-adjusting as to contact making and each socket contact shall be such as to make and maintain, in normal use, effective electrical and mechanical contact with a corresponding plug pin. The means for producing the contact pressure shall be associated with each socket contact independently and shall not rely on any insulating material in contact with the socket contact.

13.5.1 Conformity shall be checked by inspection and, except for shaver adaptors, by the tests given in **13.5.2** and **13.5.3**, as appropriate.

13.5.2 The voltage drop between any individual line or neutral socket-contact and the corresponding plug pin is measured between the terminal connecting strap at a point immediately adjacent to the socket-contact and the corresponding plug pin. Other than when tested in accordance with **18.1.2** and **18.1.3**, the voltage drop shall not exceed 25 mV at rated current.

13.5.3 For adaptor socket-outlets for **SLS 734** plugs, the withdrawal pull of a gauge as shown in Figure 17a) for individual earth socket contacts and in Figure 17b) for individual line or neutral socket contacts is checked whilst ensuring that neither the shutter mechanism, nor any insulating material in contact with the socket contact has any effect on the results of the test. The socket contact shall retain the gauge for not less than 30 s when the socket-outlet is held horizontally with the gauge hanging vertically downwards.

Adaptor socket-outlets for 5 A plugs conforming to **SLS 948** are checked using the gauge shown in Figure 6 of **SLS 948** as shown in Table 20 of **SLS 948**. The individual line or neutral socket contact is checked whilst ensuring that neither the shutter mechanism, nor any insulating material in contact with the socket contact has any effect on the results of the test. The socket contact shall retain the gauge for not less than 30 s when the socket-outlet is held horizontally with the gauge hanging vertically downwards.

13.6 The construction of adaptors shall be such as to allow for easy withdrawal of a plug from the socket-outlets.

A plug is inserted into and withdrawn from the socket-outlet ten times with the adaptor mounted as in normal use.

13.6.1 Conformity shall be checked by the following test.

An appropriate plug having pins of maximum dimensions on nominal centres is inserted into and withdrawn from the socket-outlet ten times with the adaptor mounted rigidly.

For shaver adaptors three types of plug shall be used, as specified in **18**.

NOTE: *Care should be taken to remove any grease from the plug pins and socket contacts prior to the tests.*

Each socket-outlet of the adaptor shall be tested in turn.

The plug is then inserted into the adaptor socket-outlet and a force is gradually exerted in a direction parallel to the axis of the pins. For shaver-outlets and for adaptor socket-outlets for **SLS 734** plugs it shall not be possible to reach a pull of 36 N without the plug coming out of the adaptor socket-outlet.

For adaptor socket-outlets for 5 A plugs conforming to **SLS 948**, the maximum force shall be that specified in Table 15 of **SLS 948**.

13.7 The construction of the adaptor shall be such that when a plug is withdrawn from it the current-carrying socket contacts are automatically screened by shutters. The shutter shall be operated either by the insertion of the earthing pin or by the simultaneous insertion of any two or more pins of the plug, provided that any one corresponding single pin inserted into any Current-carrying socket aperture shall not open the shutter. One socket aperture shutter shall not be capable of closing independently of the other aperture shutter. Conformity shall be checked by the tests of **13.7.1**.

It shall not be possible to operate a shutter by inserting a 2-pin plug into a 3-pin socket-outlet. Conformity shall be checked by the tests of **13.7.2**.

13.7.1 Conformity shall be checked by inspection, before and after the test described in **18**, and by the application of the corresponding single pin applied to the shutter using a force of $5^{0}_{-0.1}$ N. The test pin shown in Figure 1 is then applied to the shutter using a force of $5^{0}_{-0.1}$ N applied perpendicular to the engagement surface of the socket-outlet. It shall not be possible to touch current-carrying parts.

13.7.2 Earth pin operated shutters and 3-pin operated shutters shall be deemed to conform to this requirement without testing. For other shutter designs, conformity shall be checked by the following test.

A 2-pin plug conforming to **BS EN 50075** shall be applied to the socket line and neutral apertures with a force of 30^{0}_{-2} N. The plug pins, when applied in any direction, shall not make contact with live parts.

13.8 For adaptors with adaptor socket-outlets for **SLS 734** plugs, apertures for the reception of the line and the neutral plug pins shall not exceed $7.2 \text{ mm} \times 4.8 \text{ mm}$ and for the earthing pin $8.8 \text{ mm} \times 4.8 \text{ mm}$.

NOTE: *Apertures may be shaped at their front edges to facilitate insertion of plugs conforming to **SLS 734 Part 1**.*

Earth socket contacts may be flush with the front face of enclosure, but shall not depend for their effectiveness on insulating material of the enclosure. In such a case the aperture shall be measured between the contact faces at the maximum separation.

13.8.1 Conformity shall be checked by inspection and measurement.

13.9 For adaptors with adaptor socket-outlets for **SLS 734** plugs, no part of the aperture intended for the reception of the line or neutral pin shall be less than 9.5 mm from the periphery of the accessible external surface of a socket-outlet except that when a shutter is operated by the simultaneous insertion of the current-carrying pins this dimension shall be increased to 18 mm from the lower edge of the socket-outlet portion.

Where the 9.5 mm and 18 mm dimensions include a peripheral edge radius, it shall not exceed 1 mm.

13.9.1 Conformity shall be checked by inspection and measurement.

13.10 Adaptors with associated plugs and cables shall not impose undue strains on fixed socket-outlet.

13.10.1 Except for shaver adaptors, conformity shall be checked by the following tests.

a) Adaptors with three adaptor socket-outlets for **SLS 734** plugs shall be fitted with the following:

- i) one device and counterweight, simulating a plug and 1 m of 1.5 mm^2 3-core flexible cable in the outlet giving the most onerous condition. See Figure **31** (load 2);
- ii) two devices and counterweights, simulating plugs and 1 m of 0.75 mm^2 3-core flexible cable on the remaining outlets. See Figure **31** (load 1).

Adaptors with two adaptor socket-outlets for **SLS 734** plugs shall be fitted with the following:

- one device and counterweight, simulating a plug and 1 m of 1.5 mm^2 3-core flexible cable in the outlet giving the most onerous condition. See Figure **31** (load 2);

- One device and counterweight, simulating a plug and of 0.75 mm² 3-core flexible cable in the remaining outlet. See Figure 31 (load 1).

Other adaptors shall be fitted with a complete complement of appropriate devices and counterweights shown in Figure 31 (loads 3 or 4) (for 5 A outlets of SLS 948), or if no appropriate device is described, then a plug fitted with 1 m of flexible cable suitable for the current rating of the plug shall be fitted. Intermediate and adaptor plugs shall be fitted with 1 m of appropriate flexible cable.

The total mass shall not exceed 800 g.

NOTES:

- 1) *Devices as shown in Figure 31 may be modified to suit particular adaptors, provided the mass/turning moment characteristics remain unchanged.*
- 2) *A suitable device for calibrating simulated plugs is shown in Figure 32.*
- b) The adaptor with devices and counterweights or plugs and flexible cables as described in item a) shall be inserted into a socket-outlet conforming to **SLS 734 Part 2**. The socket-outlet shall be pivoted about its horizontal axis, 8 mm behind the engagement face and parallel with it, with its centre equidistant from pin centres. The additional torque which has to be applied to the socket-outlet to maintain the engagement face in the vertical plane shall not be greater than 0.7 Nm. Care shall be taken that flexible cables, if any, hang freely during the test.
- 3) *A device for checking this requirement is shown in Figure 33.*

13.11 Adaptor socket-outlet contacts shall withstand the strain imposed on them by associated plugs and cables.

13.11.1 Conformity shall be checked for adaptor socket-outlets for plugs conforming to SLS 948 (5 A only) and SLS 734 by the following test, except for shaver adaptors.

The adaptors shall be rigidly mounted with the axis of plug pins horizontal and the earth pin uppermost. The appropriate device and counterweight shown in Figure 31 shall be fully inserted into the adaptor outlet being tested and removed after 1 min. The adaptor is turned through 90° on the mounting surface with the plug pin axis still horizontal and the device and counterweight fully inserted. The test is made four times, the adaptor being moved 90° after each insertion and removal.

During the test the device and counterweight shall not come out. After the test, the adaptor shall show no damage within the meaning of this standard and the contacts shall retain for not less than 30 s the relevant weight gauges shown in Figure 17a and Figure 17b for adaptor socket-outlets for SLS 734 plugs when the face tested is held horizontally and the weight gauges are hanging vertically downwards. For adaptor socket-outlets for 5 A plugs conforming to SLS 948 the gauges of Figure 6 and Table 20 of SLS 948 shall be used. The test shall be repeated for each adaptor socket-outlet.

13.12 Switches shall be so constructed that undue arcing cannot occur when the switch is operated slowly. The switch shall disconnect at least the line circuit. Double pole switches shall make and break each pole with one movement of the actuator.

13.12.1 Conformity shall be checked by inspection and by the following test. Following the test described in **17.1.3**, the circuit is broken a further ten times, each time moving the actuating member by hand over a period of approximately 2 s in a manner such as to attempt to stop the moving contact in an intermediate position causing arcing. The actuating member shall be released after approximately 2 s and any arcing shall cease.

13.12.2 The actuating member of a switch shall not remain at rest in the 'off' position whilst the switch contacts remain closed. The actuating mechanism shall be so constructed that when operated the switch can remain only in a position giving adequate contact or adequate separation of contacts. For switched adaptors that cannot be dismantled after assembly an additional new set of three samples prepared with the contacts closed is supplied by the manufacturer for this test.

13.12.2.1 Conformity shall be checked by inspection and by the test of **13.12.3**.

13.12.3 The necessary force F to switch off shall first be measured and the force shall be applied to the extremity of the actuating member.

With the actuating member of the switch in the closed position, the fixed and moving contacts of each pole shall be mechanically fixed together to provide the most onerous condition.

The method for fixing the contacts shall not unduly affect the test result. The test sample may be dismantled where necessary in preparation for this test and the test sample and components shall not be damaged during this preparation.

The actuating member shall be subjected to a test force as defined in Table 7. This force shall be applied in one smooth and continuous motion to the extreme point of the actuating member in the most favourable direction to open the contacts for a period of 10 s.

If locking means are designed to lock the actuating members in opened position, it shall not be possible to lock the actuating members in this position while the force is applied.

After the test and when the test force is no longer applied, the actuating member shall not remain at rest in the "off" position.

TABLE 7- Actuator test force

Type of actuator	Test force	Minimum test Force N	Maximum test force N
(1)	(2)	(3)	(4)
Switch actuator	$3F$	50	150

F is the normal operating force in new condition. The test force shall be $3F$ with the stated minimum and maximum values applied.

Á

NOTE: *The use of grease and the like is not considered to be a mechanical fixing means.*

14 RESISTANCE TO AGEING AND TO HUMIDITY

14.1 Resistance to ageing

Adaptors shall be resistant to ageing.

14.1.1 Conformity shall be checked by the following test.

The adaptors are subjected to a test in a heating cabinet with an atmosphere having the composition and pressure of the ambient air and ventilated by natural circulation.

The temperature of the cabinet is kept at $70\text{ °C} \pm 5\text{ °C}$.

The samples are kept in the cabinet for $168\text{ }^{+2}_0\text{ h}$.

Á

NOTES:

Á

1) *The use of an electrically heated cabinet is recommended.*

2) *Natural circulation may be provided by holes in the walls of the cabinet.*

After the treatment, the samples are removed from the cabinet and kept at room temperature and relative humidity for 1 h; following which they are examined and shall show no damage which:

- Á would lead to non-conformity with this standard;
- Á would impair safety; or
- Á would prevent further use.

14.2 Resistance to humidity

Adaptors shall be resistant to humid conditions which may occur in normal use.

14.2.1 Conformity shall be checked by the humidity treatment described below followed within 20 min by the measurement of the insulation resistance and by the electric strength test specified in **15**.

Rewirable intermediate adaptor and adaptor plugs are fitted with $1\ 000\text{ mm} \pm 50\text{ mm}$ of 3-core 1.5 mm^2 PVC cable as given in **SLS 1504 -2-11** Non-rewirable adaptors are tested with $1\ 000\text{ mm} \pm 50\text{ mm}$ of the flexible cable with which they are supplied measured from the centre of the earth pin.

Vitrified ceramic material, which after 24 h immersion in water has not increased in mass by more than 0.5 per cent after all the moisture has been removed from its surface, shall not be subjected to further tests, providing the resistance to water of the material does not depend on glaze or varnish.

To suit the ambient conditions at the time of test, a convenient temperature, T ($^{\circ}\text{C}$) between 20°C and 30°C , is chosen as a reference temperature. The sample is brought to a temperature of between $T^{\circ}\text{C}$ and $T + 4^{\circ}\text{C}$ and then placed in a humidity cabinet containing air with a relative humidity maintained between 85 per cent and 95 per cent. The temperature of the air where the samples are placed shall be kept within $\pm 2^{\circ}\text{C}$ of the chosen value T .

The sample shall be kept in the cabinet for 48^{+1}_0 h.

NOTES:

Á

1) *In most cases samples may be brought to the chosen temperature by keeping them at this temperature for at least 4 h before the humidity treatment.*

2) *A relative humidity of between 85 per cent and 95 per cent can be obtained by placing in the humidity cabinet a saturated solution of potassium nitrate (KNO_3) or sodium sulfate (Na_2SO_4) in water having a sufficiently large contact surface with the air.*

In order to achieve the specified conditions within the cabinet, it is necessary to ensure constant circulation of the air within the cabinet and, in general, to use a cabinet which is thermally insulated.

The tests described in **15** shall be made in the humidity cabinet or immediately after removal of the sample from the cabinet in a room where the specified temperature is maintained. Inspection shall not reveal any damage to the sample which would impair its use or safety within the requirements of this part of **SLS 734**.

15 INSULATION RESISTANCE AND ELECTRIC STRENGTH

15.1 The insulation resistance and electric strength of adaptors shall be adequate.

15.1.1 Conformity shall be checked by the tests given in **15.1.2** and **15.1.3**.

15.1.2 The insulation resistance is measured using a d.c. voltage of 500^{+250}_0 V, the measurement being made for 60^{+5}_0 s after application of the voltage. The insulation resistance is measured consecutively between:

a) line and neutral terminals/terminations;

b) Áine and neutral terminals/terminations connected together and:

i) Áa metal foil in contact with the entire accessible external surface;

ii) Áthe earthing terminal/termination;

iii) Áany metal part of a cable anchorage;

c) each switched pole of a switched adaptor and corresponding plug pin, with the switch contact open.

The insulation resistance shall be not less than the following:

- i) $5 \text{ M}\Omega$ between parts of opposite polarity;
- ii) $5 \text{ M}\Omega$ between parts of opposite polarity connected together, and other parts, including earthed metal, intended to be insulated from them;
- iii) $2 \text{ M}\Omega$ across switch contacts with the switch open, where applicable.

One pole of neon indicators and the like shall be disconnected before making this test.

Where terminals/terminations are not directly accessible, e.g. in non-rewirable intermediate adaptors and adaptor plugs, these tests shall be made using accessible parts, e.g. pins known to be connected to the terminations.

15.1.3 A 50 Hz voltage of substantially sinusoidal waveform is applied as described in **15.1.2**. Initially, not more than 1 000 V is applied, the voltage is then raised to $2\,000 \text{ V} \pm 60 \text{ V}$. The high voltage source used shall be such that when the output is adjusted to $2\,000 \text{ V} \pm 60 \text{ V}$ for 60^{+5}_0 s , and is then short-circuited, the output current is not less than 200 mA. Any over current protection shall not operate at a current less than 100 mA.

During the test no flashover or breakdown shall occur.

Glow discharges without drop in voltage shall be ignored.

One pole of neon indicators and the like shall be disconnected before making this test.

15.2 Non-rewirable intermediate adaptors or adaptor plugs shall withstand a high voltage test, for which the test voltage shall be alternating (50 Hz to 60 Hz), applied between all current-carrying parts connected together and a conducting electrode in contact with the entire outer accessible surface, omitting the engagement face. This test shall be carried out at $6\,000 \text{ V} \pm 100 \text{ V}$ for a period between 3 s and 5 s.

During the test no breakdown or flashover shall occur.

Glow discharges without drop in voltage shall be ignored.

16 TEMPERATURE RISE

16.1 Adaptors and their surroundings shall not attain excessive temperatures in normal use.

16.1.1 Conformity shall be checked by the following tests.

For adaptors with adaptor socket-outlets for **SLS 734** plugs, the standard test plug described in Annex **G** shall be used.

For adaptors with adaptor socket-outlets for 5 A plugs, conforming to **SLS 948** fitted with $1\,000 \text{ mm} \pm 50 \text{ mm}$ of appropriate PVC insulated flexible cable as specified in **SLS 1504-2-11**, to suit the maximum current rating of the plugs, shall be used. For shaver adaptors the test plug as detailed in Figure **30** fitted with $1\,000 \text{ mm} \pm 50 \text{ mm}$ of twin circular 0.5 mm^2 flexible cable (see **SLS 1504 -2-11**) shall be used.

Non-rewirable intermediate adaptors shall have the cable supplied cut to 1 000 mm \pm 50 mm length. Rewirable intermediate adaptors shall be fitted with 1 000 mm \pm 50 mm of 1.5 mm² PVC insulated flexible cable (see **SLS 1504-2-11**) having the appropriate number of cores. The L in and L out cores shall be linked at their extremity to provide a normally closed path.

Adaptor plugs are tested with 1 000 mm \pm 50 mm of 1.5 mm² 3-core PVC insulated flexible cable (see **SLS 1504-2-11**) if they are rewirable, or with 1 000 mm \pm 50 mm of the flexible cable supplied if non-rewirable.

Adaptors with fuses conforming to **SLS 1533** shall have the fuse replaced with a calibrated link constructed and calibrated in accordance with Annex A.

Adaptors with fuses conforming to **SLS 1552** shall be fitted with a **SLS 1552** fuse link of 5 A rating.

Shaver adaptors shall be fitted with a **SLS 1552** fuse link of 1 A rating.

During the tests, the temperature rises are measured at the terminals or terminations (if any) and where overheating might result in a hazard.

16.12 Tests shall be carried out as follows.

- a) For adaptors where all the adaptor socket-outlets are for **SLS 734** plugs, a series of tests shall be conducted by inserting the standard test plug into each socket-outlet in turn and, in each test, a current of 14 A \pm 0.4 A shall be passed through the assembly.
- b) For other adaptors:
 - i) where there is one adaptor socket-outlet for **SLS 734** plugs plus other types and ratings to other standards; or
 - ii) where all adaptor socket-outlets are for plugs of types and ratings to other standards; or
 - iii) in adaptor plugs where there is one adaptor socket-outlet for **SLS 734** plugs plus an outlet for a flexible cable;

a series of tests shall be conducted by inserting an appropriate test plug into each socket-outlet in turn, or by applying a load via the flexible cable of an adaptor plug. In each test a current as specified below shall be passed through the assembly.

- i) For socket-outlets rated at 13 A or higher, the test current shall be 14 A \pm 0.4 A.
- ii) For other socket-outlets and for flexible cables, the test current shall be equal to 110 per cent of the respective rating but in no case shall an individual test current exceed 14 A.
- iii) For multiway adaptors, an additional test shall be conducted by inserting an appropriate test plug into each socket-outlet and, or an adaptor plug, by connecting a

load via the flexible cable. An electrical load equal to 110 per cent of the total connectable load but not exceeding a maximum value of 14 A shall then be passed through the complete assembly dividing this current between all the socket-outlets, including the flexible cable, if any, in proportion to their respective current ratings.

iv) For shaver adaptors, the test current shall be 1 A \pm 0.1 A.

Where fitted with USB battery charging outlets these shall be loaded with their rated currents ($+10_0$ %) for the duration of the tests.

The tests shall be carried out at a rated voltage $^{+10}_{-2\%}$ U_n.

For these tests, where conductors are connected to terminals, the terminal screws shall be tightened with a torque equal to two thirds of the values given in Table 6.

During the tests temperature rises are measured and the values shall not exceed those given in Table 8.

TABLE 8 -Permitted temperature rises

Measurement point	Temperature rise K
Line pin spacer (see Figure 18 and 19)	37
Neutral pin spacer (see Figure 18 and 19)	37
Terminals or termination of intermediate adaptors or adaptor plugs	52
Accessible external surface	52

NOTE: *The recording of a measured value up to and including the specified maximum permissible limit for temperature rise is considered to conform to the requirements of the standard on condition that the uncertainty of measurement at not less than 95 per cent confidence level does not exceed ± 2 °C.*

The temperature rises of the line and neutral pins of the adaptor are measured by means of thermocouples using the apparatus shown in Figure 18 and Figure 19 . Temperature rises are determined by means of fine wire thermocouples so chosen and positioned that they have minimum effect on the temperature of the part under test. The thermocouples are attached by means of a mixture of equal parts of resin adhesive and zinc oxide, by soldering, or by other equally effective means.

NOTE: *If soldering is used, it is essential that care is taken to ensure that the heat from the soldering process does not affect the performance of the adaptor and that no electrical connections are bridged by solder.*

If, in order to fix thermocouples, a non-rewirable adaptor is dissected to give access to the appropriate positions, the removed parts shall be replaced and if necessary shall be cemented in place so that no additional air spaces are created.

The adaptor is mounted in a flat insulating plate as shown in Figure 18 and Figure 19. The supply conductors are attached to the line and neutral pins of the adaptor by means of clamps which also serve to retain the adaptor in position. The clamp screws are tightened to a torque of between 0.8 Nm and 1.2 Nm. The assembly is mounted by means of screws in a standard steel flush-mounted socket-outlet box as shown in Figure 1b) of SLS 1310 having a nominal internal depth of 35 mm which is mounted in a test cabinet as shown in Figure 18. The incoming cable and outgoing flexible cable(s) shall enter the test cabinet through holes in the top surface which shall then be sealed to prevent circulation of air. The length of cable and flexible cable within the Figure 18 enclosure shall be a maximum length of 600 mm and 850 mm, respectively. Care shall be taken to position the cable and flexible cable away from the reference temperature measuring point so as not to influence the derivation of plug temperature rise values.

The incoming cable shall be 2.5 mm² PVC insulated and sheathed cable, as given in Table 4 of SLS 733 and shall enter the socket-outlet mounting box through the standard knock-out provided. This shall be fitted with a suitable rubber grommet, the point of entry being sealed to prevent the circulation of air. The length of cable within the socket-outlet box shall be 150 mm ±5 mm and the outer sheath and the circuit protective conductor shall be removed to within 20 mm of the point of entry. The test cabinet (see Figure 18) is placed in an environment having an ambient temperature of 20 °C ±5 °C. The test current shall be passed through the adaptor and through a load(s) connected to the flexible cable of the test plug(s) for a minimum continuous period of 4 h or longer until stability is reached with a maximum duration of 8 h, stability being taken as less than 1 K rise within 1 h.

The temperature rise is calculated by deducting the reference point temperature from the measurement point temperature recorded (see Figure 18 and Figure 19 (respectively)).

17 BREAKING CAPACITY OF ADAPTORS

17.1 The breaking capacity of socket contacts and switches incorporated in adaptors shall be adequate.

17.1.1 Except for shaver adaptors, conformity shall be checked by the tests described in 17.1.2 and 17.1.3 as applicable, which shall be completed with the adaptors connected and mounted as in normal use.

NOTE: *Shaver adaptors are deemed to conform without testing.*

17.1.2 The socket contacts shall make and break a current of 1.25 times rated current ±0.4 A, i.e. (1.25 × 13) A ±0.4 A in a substantially non-inductive a.c. circuit at 250 V ±5 V, ten times in succession at intervals of approximately 30 s, a plug being withdrawn from the socket-outlet at a speed of approximately 150 mm/s immediately after insertion. For the purpose of the test the fuse link may be replaced by a link of negligible impedance.

After the test, the socket-outlet shall be capable of satisfying the subsequent tests detailed in Table 1 for the appropriate test sample.

17.1.3 The switch shall make and break a current of 1.25 times rated current ± 0.4 A in a substantially non-inductive a.c. circuit of 275 V ± 5 V, ten times in succession at intervals of approximately 30 s. After the test, the adaptor shall be capable of passing the subsequent tests specified in Table 1 for the appropriate test sample.

18 NORMAL OPERATION OF ADAPTORS

18.1 Adaptors shall withstand without excessive wear or other harmful effects, the electrical and mechanical stresses occurring in use.

18.1.1 For adaptors other than shaver adaptors, conformity shall be checked by the tests described in **18.1.2** and **18.1.4** and for shaver adaptors by the tests described in **18.1.3**.

18.1.2 Using an appropriate plug with solid pins, each socket-outlet of the adaptor shall make and break a current equal to the rated current ± 0.4 A of the adaptor, or if the rated current ± 0.4 A of the plug is lower, the rated current of the appropriate plug at 250 V ± 10 V a.c. 15 000 times (30 000 movements) in a substantially non-inductive circuit.

Each plug is inserted into and withdrawn from the socket-outlet under a test at a rate of approximately six insertions and withdrawals per minute, the speed of travel of the plug being approximately 150 mm/s.

The periods during which the plug is inserted and withdrawn are approximately equal. Each socket-outlet on the adaptor shall be tested in turn, the plug pins are renewed after each 5 000 insertions and withdrawals. For the purposes of this test, no lubrication is applied to the plug or socket-outlet under test.

After the test the shutter shall be operating satisfactorily, the socket contacts safely shielded and the adaptor shall be in accordance with **13.7**, **9.1**, **16**, **15**, **13.5**, **13.6** and **10.2**. The permitted value of voltage drop specified in **13.5.2** is increased to not greater than 40 mV.

18.1.3 Shaver adaptors shall be tested without making and breaking a current, i.e. purely mechanical test.

For the test, three shaver adaptors shall be used, each being tested with one type of plug only. The three plugs shall be:

- a) UK, conforming to **BS 4573**;
- b) USA, as referred to in **IEC 60083**, sheet US1, NEMA 1-15;
- c) European, conforming to **BS EN 50075**.

After the test the shutter shall be operating satisfactorily, the socket contacts shall be safely shielded and the adaptor shall be in accordance with **13.7**, **9.1**, **16**, **15**, **13.5.2**, **13.6** and **10.2**. The permitted value of voltage drop specified in **13.5.2** is increased to not greater than 40 mV.

18.1.4 In switched adaptors the voltage drop across each switched pole, measured at

points immediately adjacent to the switch, shall not exceed 60 mV at rated current.

The switch shall then make and break its rated current ± 0.4 A at 250 V ± 10 V 15 000 times (30 000 movements) in a substantially non-inductive a.c. circuit at a rate of approximately six complete cycles per minute at regular intervals. The periods during which the switch is “on” and “off” shall be approximately equal. The means used for operating the switch shall be such as to move the actuating member at a speed of approximately 300 mm/s both in making and breaking the circuit and shall be so positioned that the normal action of the mechanism is not interfered with in any way.

At the end of the test, the switch shall be capable of making and breaking its rated current ± 0.4 A at 250 V ± 10 V and the voltage drop across each switched pole, measured as above, shall not exceed 75 mV.

The switch shall also pass the tests given in **15**, the test voltages given in **15.1.3** being reduced by 25 per cent.

19 CONNECTION OF FLEXIBLE CABLES AND CABLE ANCHORAGE IN INTERMEDIATE ADAPTORS AND ADAPTOR PLUGS

19.1 Provision shall be made for the entry and effective clamping without bending of 2-core and 3-core flexible cables for rewirable adaptors as given in **SLS 1504-2-11**, **SLS 1504-2-21**, **SLS 1504-2-22** and **SLS 1504-2-71**, having nominal conductor cross-sectional areas not exceeding 1.5 mm².

For non-rewirable adaptors provision shall be made for the entry and adequate retention of the flexible cable with which the plug is supplied, once assembled it shall not be possible to affect the integrity of the cable anchorage.

The entry for the flexible cable shall be between the current-carrying pins at the side of the adaptor opposite the earth pin.

The cable anchorage shall be such that the conductors are relieved from strain, including twisting, where they are connected to the terminals or terminations.

The cable anchorage shall contain the sheath. Cable anchorages shall either be of insulating material or, if of metal, shall be provided with an insulating lining fixed to the metal parts.

Methods such as tying the flexible cable into a knot or tying the ends with string, etc. shall not be used.

19.1.1 Conformity shall be checked by inspection and by the following tests.

- a) Rewirable adaptors are fitted with a 2-core flexible cable having a nominal conductor cross-sectional area as given in **SLS 1504-2-71**. The conductors are introduced into the terminals and the terminal screws tightened to one third of the appropriate torque values listed in Table **6**. The cable anchorage is used in the normal way, the clamping screws, if any, being tightened to a torque of two thirds of that given in Table **6**. The assembly is then left untouched for a minimum of 24 h.

After this preparation, it shall not be possible to push the flexible cable into the adaptor to such an extent as to impair safety or so that the cable anchorage is loosened. The flexible cable is then subjected 25 times to the pull given in Table 2. The pulls are applied in one smooth and continuous motion in the most unfavorable position momentarily. Immediately afterwards, the flexible cable is subjected for 60^{+5}_0 s to the appropriate torque shown in Table 2, at a minimum starting distance of 150 mm from the cable entry measured along the length of the cable.

NOTE: *It is not intended that the dimension of 150 mm is maintained during the application of the test torque.*

The tests are then repeated but with the rewirable adaptor fitted with a 3-core flexible cable having a nominal conductor cross-sectional area of 1.5 mm^2 as given in **SLS 1504-2-11**.

- b) For non-rewirable adaptors, the test is carried out with the cable with which the adaptor is supplied and using the load and torque given in Table 2. The conductors of the flexible cable are severed at the point of termination prior to the test.

During this test the insulation of the flexible cable shall not be damaged.

A voltage of $3\,750 \text{ V} \pm 75 \text{ V}$ is applied for 60^{+5}_0 s between the conductors. Break down or flashover is considered to indicate damage to the flexible cable.

- c) After the tests given in a) and b) the flexible cable shall not have been displaced by more than 2 mm.

For the measurement of longitudinal displacement, a mark is made on the cable whilst it is subjected to the load given in Table 2, at a point adjacent to the anchorage in the case of rewirable adaptors, or as close as practicable to the cable anchorage in the case of non-rewirable adaptors, before starting the tests. After the test, the displacement of the mark on the flexible cable in relation to the cable anchorage is measured whilst the cable is again subjected to the load given in Table 2.

19.2 Cable anchorage in rewirable adaptors shall anchor the cable securely to the adaptor. The design shall ensure the following:

- a) the cable anchorage cannot be released from the outside without the use of a tool;
- b) it shall not be possible to touch cable anchorage screws, if any, with test probe B of **IEC 61032** when the adaptor is energized;
- c) the cable is not clamped by a metal part bearing directly on the flexible cable;
- d) at least one part of the anchorage is securely fixed to the adaptor;
- e) clamping the cable does not require the use of a special purpose tool;
- f) tightening the cable anchorage screws if any to the torque specified in Table 6 does not distort the engagement surface of the adaptor to such an extent that conformity with **12.2** is affected;

g) the adaptor may be correctly assembled without damage when it is wired with the largest specified flexible cable and all screws are tightened to the torque specified in Table 6.

19.2.1 Conformity shall be checked by inspection and test.

19.3 Screws which are used when clamping the flexible cable shall not serve to fix any other components unless the adaptor is rendered manifestly incomplete if the component is omitted or is replaced in an incorrect position, or the component intended to be fixed cannot be removed without further use of a tool.

19.3.1 Conformity shall be checked by inspection.

19.4 Non-rewirable adaptors shall be fitted with flexible cables conforming to the relevant parts of **SLS 1504** or with flexible cables conforming to the requirements of the specification appropriate to the equipment to which they may be fitted. Connections shall be as given in Table 9.

19.4.1 Conformity shall be checked by inspection and a continuity test.

19.5 Non-rewirable adaptors shall be so designed that the flexible cable is not subjected to excessive bending where it enters the adaptor.

19.5.1 Conformity shall be checked by the following test using an apparatus similar to that shown in Figure 20. The adaptor is fixed to the oscillating member of the apparatus so that when this is vertical the axis of the flexible cable at the point of entry is vertical and passes through the axis of oscillation.

Adaptors with flat flexible cables are mounted so that the major axis of the section is parallel to the axis of oscillation. The flexible cable is loaded with a weight such that the force is as given in Table 2.

The distance between the point of entry to the adaptor and the axis of oscillation is adjusted so that the weight makes the minimum lateral movement as the oscillating member moves. A current appropriate to the flexible cable fitted, as given in Table 2, is passed through the line and neutral conductors, the voltage between them being $250 \text{ V} \pm 10 \text{ V}$ a.c. If an earthing conductor is incorporated in the flexible cable it shall be connected at one end to the neutral conductor. The oscillating member is moved backwards and forwards through an angle of $45^\circ \pm 3^\circ$ on either side of the vertical, the number of flexings being 10 000 at a rate of 60 _{-10}^0 flexings per minute.

After 5 000 flexings, adaptors with cables of circular section are turned through $90^\circ \pm 5^\circ$ about the cable entry centreline.

NOTE: *A flexing is one movement through 90° , either backwards or forwards.*

During the test there shall be no interruptions of the current passing through the conductors and no short-circuit between them.

After the test the adaptors shall show no damage except that breakage of no more 10 per cent of the total number of conductor strands in any core is ignored, provided they have not pierced the insulation.

19.6 The cable entry to rewirable adaptors shall be so shaped as to prevent damage to the cable.

19.6.1 Conformity shall be checked by inspection.

TABLE 9 -Connection of flexible cables

Termination	Conductor insulation colour		SLS 1504-2-71	4-core cables for intermediate adaptors	
	SLS 1504-2-11 SLS 1504-2-21 SLS 1504-2-22				
(1)	(2)	(3)	(4)	(5)	(6)
	3-core	2-core	2-core	Terminal	Colour
Earth	Green-and-yellow	No connection	No connection	Earth	Green- and-yellow
Line	Brown	Brown	As supplied	L in/L1	Brown
Neutral	Blue	Blue	As supplied	L out/L2	Black
				Neutral	Blue

20 MECHANICAL STRENGTH

20.1 Adaptors shall have adequate mechanical strength and be so constructed as to withstand such handling as may be expected in normal use.

20.1.1 Conformity shall be checked for the following:

- a) adaptors fitted with **SLS 1533** fuse links by the tests of **20.1.2**;
- b) adaptors fitted with **SLS 1552** fuse links by the tests of **20.1.3**;
- c) following which, all adaptors are subjected to the tests given in **20.1.4** and **20.1.5** using separate samples for each of these tests.

20.1.2 For fused adaptors using fuse links conforming to **SLS 1533**, a solid link of stainless steel as shown in Figure 21 is inserted and withdrawn from the fuse clips of a fused adaptor 20 times in succession in a normal manner, at a rate not exceeding ten per minute. A standard fuse link conforming to **SLS 1533** is then fitted with the appropriate mechanical strength test completed.

20.1.3 For fused adaptors using fuse-links conforming to **SLS 1552**, a solid link of stainless steel as shown in Figure 34 is inserted and withdrawn from the fuse clips of the fused adaptor twenty times in succession in a normal manner, at a rate not exceeding ten per minute. A standard fuse link conforming to **SLS 1552** is then fitted and the appropriate mechanical strength test completed.

20.1.4 Adaptors are tested with the impact test apparatus shown in Figure 23a when mounted in a socket-outlet. The pendulum consists of a steel tube with an external diameter of 9 mm and a wall thickness of 0.5 mm, suspended in such a way that it swings only in a vertical plane. A hammer is rigidly fixed to the lower end.

The striking element has a hemispherical face made of polyamide having a Rockwell hardness of $85 \leq \text{HRR} \leq 100$, or hornbeam, and a radius of $10 \text{ mm} \pm 0.5 \text{ mm}$ (see Figure **23b**). The design of the apparatus is such that a force of between 1.9 N and 2 N has to be applied to the face of the hammer to maintain the pendulum in a horizontal position.

A flush socket-outlet conforming to **SLS 734** is mounted with its associated box, which is placed in a block of hardwood which is itself fixed to a sheet of plywood. The wood used shall have the direction of the wood fibres perpendicular to the direction of impact.

To simulate the condition of normal use, the rear of the plate is flush with the surface of the block. The front edge of the box is between 2.5 mm and 5 mm behind the face of the block.

The mounting support (see Figure **23c**), having a mass of $10 \text{ kg} \pm 1 \text{ kg}$ is mounted on a rigid bracket by means of pivots. The bracket is mounted on a frame which is fixed to a solid wall.

The design of the mounting assembly shall be such that:

- a) the sample can be so placed that the point of impact lies in the vertical plane through the axis of the pivot of the pendulum;
- b) the sample can be moved horizontally and turned about an axis perpendicular to the surface of the plywood;
- c) the plywood can be turned about a vertical axis.

The adaptor is inserted into the socket-outlet so that the point of impact lies in the vertical plane through the axis of the pivot of the pendulum. For all tests the hammer falls from a height of 150_{-5}^0 mm measured vertically between the point of impact on the sample and the face of the hammer at the point of release. Ten blows are applied to points evenly distributed over the adaptor, and any lens receives one blow of the hammer at a point approximately in its centre.

After the test the adaptor shall still be in accordance with **8**, **9** and **15**. After the test on a lens, the lens may be cracked and/or dislodged, but it shall not be possible to touch live parts using the test pin shown in Figure **1** applied with a maximum force of 5 N applied in accordance with **9.1.1**.

Damage to the finish, small dents which do not reduced creepage distances and clearances below the values specified in **8** and small chips that do not adversely affect the protection against electric shock or moisture shall be ignored.

Cracks not visible with normal or corrected vision without additional magnification, and surface cracks in fibre reinforced mouldings and the like shall be ignored.

20.1.5 Adaptors are tested in the tumbling barrel shown in Figure **22**. The barrel is turned at a rate of approximately 5 r/min (approximately ten drops per minute). Only one adaptor is tested at a time. The number of drops shall be 25. Rewirable intermediate adaptors and adaptor plugs are fitted with 3-core PVC 1.5 mm^2 flexible cable as given in **SLS 1504 -2-11**, the terminals and cover screw being tightened with the torque given in Table **6**. The connection of conductors shall be in accordance with the manufacturer's instructions.

Non-rewirable intermediate adaptors and adaptor plugs are tested as delivered.

The attached flexible cables are cut to a length of 150 mm \pm 5 mm measured from the nearest edge of the earthing pin, pre-coiled flexible cables being extended before measurement.

After the test the adaptor shall show no damage which might affect safety, no component parts shall have become detached, and the pins of the adaptor shall not have been unduly distorted, checked using the gauge shown in Figure 7 when used in a manner as described in 12.2.1 but with a force not exceeding 20 N.

Screws shall remain tight to a torque not less than 70 per cent of the original tightening torque and current-carrying joints shall not have become loose and shall make satisfactory contact.

Damage to the finish, small dents which do not reduce creepage distances and clearances, below the values specified in 8 and small chips that do not adversely affect the protection against electric shock or moisture shall be ignored.

20.1.5.1 Conformity shall be checked by inspection and the temperature rise test of 16.

For the repeat test given in 16, the attached flexible cable (if any) is retained without disturbing the terminal connections, but the conductor insulation and sheath are removed only as far as is necessary for the attachment of a 1 000 mm \pm 50 mm length of flexible cable of the same type as that already attached to the adaptor, the connection being made by means of a connector having a current rating appropriate to that of the flexible cable.

21 SCREWS, CURRENT-CARRYING PARTS AND CONNECTIONS

21.1 Screwed connections, electrical and otherwise, shall withstand the mechanical stresses occurring in normal use. Screws directly transmitting electrical contact pressure shall screw into metal. Screws shall not be of metal which is soft and liable to creep.

Screws shall not be of insulating material if their replacement by a metal screw would affect the safety of performance requirements of the adaptor.

Contact pressure in electrical connections within the adaptor-outlet and between the adaptor-outlet and the cable or flexible cable connected to it shall not be transmitted through insulating material other than ceramic, pure mica or other material with characteristics no less suitable, unless there is sufficient resiliency in the metallic parts to compensate for any possible shrinkage or yielding of the insulating material.

NOTE: *The suitability of other materials is considered in respect of the stability of the dimensions under all conditions of normal use especially in view of shrinking, ageing or cold flow of the insulating part.*

21.1.1 Conformity shall be checked by inspection and, for screws and nuts which are intended to be tightened during installation or use, or during replacement of the fuse link, by the following test.

The screw is tightened and loosened as follows:

- a) ten times for screws in engagement with a thread of insulating material the screw being completely removed and replaced each time;
- b) five times for nuts and other screws.

When testing terminal screws and nuts, a 1.5 mm² flexible conductor is placed in the terminal. The conductor is moved each time the screw is loosened. The test is made by means of a suitable test screwdriver, applying a torque as given in Table 6 in one smooth and continuous motion. The shape of the blade of the test screwdriver shall suit the head of the screw being tested.

During the test no damage impairing the further use of the screwed connection shall occur.

21.2 Thread cutting and/or thread-forming screws shall not be used for the making of current-carrying or earth continuity connections.

Screws which make a mechanical connection between different parts of the adaptor shall be locked against loosening, if the connection carries current.

Rivets used for current-carrying or earth continuity connections shall be locked against loosening, if these connections are subject to torsion in normal use which is likely to loosen the connection.

21.2.1 Conformity shall be checked by inspection and by manual test.

NOTES:

1) *Spring washers and the like may provide satisfactory locking.*

2) ~~For rivets, a non-circular shank or an appropriate notch may be sufficient.~~

21.3 Current-carrying parts, earthing plug pins and earthing contacts shall be of brass, copper, phosphor-bronze or other metal at least equivalent with regard to its conductivity, resistance to abrasion and resistance to corrosion, except for screws, nuts, washers, clamping plates and similar parts of terminals, nor to parts of adaptors used for earth continuity purposes.

21.3.1 Conformity shall be checked by inspection and by the relevant tests described in 10.2, 16 and 24.

22 RESISTANCE TO HEAT

22.1 Adaptors shall be resistant to heat.

22.1.1 Conformity shall be checked by the test given in 22.1.2 or 22.1.3.

22.1.2 Adaptor samples are kept for 60⁺⁵₋₀ minutes in a heating cabinet maintained at 70 °C ± 5 °C.

During the test they shall not undergo any change impairing their further use and sealing compound shall not flow to such an extent that live parts are exposed.

NOTE: *A slight displacement of the sealing compound should be disregarded.*

After the test the adaptor shall still satisfy the test described in **9.2.1** and **15.1.3**.

22.1.3 Adaptors with external parts of resilient material, e.g. thermoplastics, rubber, are subjected to a pressure test by means of an apparatus similar to that shown in Figure 24, the test being made in a heating cabinet at a temperature of $70\text{ }^{\circ}\text{C} \pm 5\text{ }^{\circ}\text{C}$.

The adaptor is clamped between the jaws in such a way that these press against it in the area where it is gripped in normal use, the centre line of the jaws coinciding as nearly as possible with the centre of this area.

The force applied through, and including the effect of, the jaws is $20\text{ }_{-1}^0\text{ N}$.

After $60\text{ }_{0}^{+5}\text{ min}$, the jaws are removed and the adaptor shall still satisfy the tests described in **15.1.2b)i)** and **15.1.3** and shall fit the gauge shown in Figure 7 when used in a manner as described in **12.2.1**.

22.2 Parts of insulating material shall be sufficiently resistance to heat having particular regard for their location and function in the complete adaptor.

22.2.1 Conformity shall be checked as follows:

- a) parts of ceramic material are deemed to conform without test;
- b) external parts of adaptors tested in accordance with **22.1.3** are deemed to conform without further testing;
- c) all other parts of insulating material, including ISODs if fitted, shall be subjected to the ball pressure test in accordance with **IEC 60695-10-2** The test is made in a heating cabinet maintained at a temperature of $75\text{ }^{\circ}\text{C} \pm 5\text{ }^{\circ}\text{C}$.

23 RESISTANCE TO ABNORMAL HEAT AND FIRE

23.1 General

Adaptors shall be resistant to abnormal heat and fire.

23.1.1 Conformity shall be checked by the test described in **23.2**. The tests shall not be made on parts of ceramic material or metal.

23.2 Glow-wire test

The test is performed in accordance in **IEC 60695-2-11** and at the test temperature given in Table 10.

TABLE 10 - Application of glow-wire test

Part	Temperature of glow-wire, °C
Parts necessary to retain live parts in position, including ISOD	750 ± 10
Parts not necessary to retain live parts in position (although they may be in contact	650 ± 10

NOTE: *If the test specified is required to be made at more than one place on the same sample. It is essential that care is taken to ensure that any deterioration caused by previous tests does not affect the result of the test to be made.*

Small parts (see 3.36), parts of insignificant mass (see 3.35), parts unlikely to be subjected to abnormal heat and parts whose failure to pass these tests would not materially affect the safety of the adaptor are not subjected to this glow-wire test.

The glow-wire test is applied to ensure that an electrically heated test wire under defined test conditions does not cause ignition of insulating parts or to ensure that a part of insulating material, which might be ignited by the heated test wire under defined conditions, has a limited time to burn without spreading fire by flame or burning parts or droplets falling down from the tested part onto a pinewood board covered with tissue paper.

The test sample shall be either a complete adaptor or, if the test cannot be made on a complete adaptor, a suitable part may be cut from one for the purposes of the test.

The test shall be made on one sample.

In case of doubt, the test shall be repeated on two further samples.

The test is made applying the glow wire once.

The sample shall be positioned during the test in the most unfavorable position of its intended use (with the surface tested in a vertical position).

The tip of the glow wire shall be applied to the specified surface of the sample taking into account the conditions of intended use under which a heated or glowing element may come into contact with the sample.

The sample shall be regarded as having passed the glow-wire test if:

- a) there is no visible flame and no sustained glowing; or
- b) the flames and glowing of the sample extinguish within 30 s after the removal of the glow wire.

There shall be no ignition of the tissue paper or scorching of the board.

24 RESISTANCE TO EXCESSIVE RESIDUAL STRESSES AND TO RUSTING

24.1 Press-formed or similar current-carrying parts of copper alloy containing less than 80 per cent of copper shall be resistant to failure in use due to stress corrosion.

24.1.1 Conformity shall be checked by the following test.

The sample is degreased in a suitable alkaline degreasing solution or organic solvent, then immersed in an aqueous solution of mercurous nitrate containing 10 g of $\text{Hg}_2(\text{NO}_3)_2$ and ten moles of HNO_3 (relative density 1.42) per litre of solution for 30 min \pm 1 min at a temperature of 20 °C \pm 5 °C.

NOTE *Attention is drawn to the fact that due precautions should be taken when using these liquids as they are toxic.*

After the treatment, the sample is washed in running water, any excess mercury wiped off, and the sample is immediately visually examined.

There shall be no cracks visible with normal or corrected vision without additional magnification.

24.2 Ferrous parts, the rusting of which might cause the adaptor to become unsafe, shall be adequately protected against rusting.

24.2.1 Conformity shall be checked by the following test.

The sample is degreased in a suitable alkaline degreasing solution or organic solvent, the parts are then immersed for 10 min \pm 0.5 min in a 10% solution of ammonium chloride in water at a temperature of 20 °C \pm 5 °C.

Without drying but after shaking off any drops, the parts are placed for 10 min \pm 0.5 min in a box containing air saturated with moisture at a temperature of 20 °C \pm 5 °C. After the parts have been dried for at least 10 min in a heating cabinet at a temperature of 100 °C \pm 5 °C their surfaces shall show no signs of rust.

NOTES:

1) *Traces of rust on sharp edges and any yellowish film removable by rubbing should be ignored.*

2) *For small helical springs and the like, and for parts exposed to abrasion, a layer of grease may provide sufficient protection against rusting. Such parts are subjected to the test only if there is doubt about the effectiveness of the grease film and the test should then be made without previous removal of the grease.*

25 OVERLOAD TESTS

25.1 Adaptors rated at 13 A shall withstand current which could occur due to overload without creating a risk of contact with live parts.

25.1.1 Conformity is checked by the tests given in **25.1.2** to **25.1.4**. The test arrangement shall be as described in **16.1** except no thermocouples or pin spacers shall be used and the test can be conducted at any voltage between 12 V and 250 V.

For adaptors with adaptor socket-outlets for **SLS 734 Part 1** plugs, a standard plug to **SLS 734 Part 1** shall be used instead of the standard test plug for the temperature rise test described in Annex **G**.

For adaptors with a single socket-outlet section, the total test current shall be passed through that single socket-outlet. For multiway adaptors, the test current shall be divided between the adaptor socket-outlets such that at least one adaptor socket-outlet is loaded with the maximum rated current for the adaptor. The plug which is to be loaded with the rated current shall be fitted with a 13 A fuse to **SLS 1533**. Other **SLS 734 Part 1** plugs which are connected to the adaptor shall be fitted with appropriately rated **SLS 1533** fuse(s). For adaptors with a flexible cable, or with provision for a flexible cable, the total test current shall pass through the connected flexible cable.

NOTE: Owing to the high temperatures which can be expected during these tests, laboratories are advised to use separate test cabinets for these tests.

25.1.2 Fused adaptors shall be fitted with a 13 A fuse to **SLS 1533** and subjected to a test current of 1.6 times the rating of the fitted fuse for 60 min or until the fuse operates (if less than 60 min). Immediately afterwards the checks specified in **25.1.4** shall be made. Fused adaptors shall then be subjected to a test current of 1.9 times the rating of the fitted fuse for 30 min or until the fuse operates (if less than 30 min). Immediately afterwards the checks specified in **25.1.4** shall be made.

25.1.3 Unfused adaptors shall be subjected to a test current of 1.6 times the rating of the adaptor for 60 min. immediately afterwards the checks specified in **25.1.4** shall current of 1.9 times the rating of the adaptor for 30 min. immediately afterwards the checks specified in **25.1.4** shall be made.

25.1.4 Each adaptor shall be checked for conformity with **9.1**, **12.7.1**, **12.8.1** and **12.13.1** except that the tests shall be performed at ambient temperature.

Deterioration which does not compromise access to live parts (e.g. discolouration, distortion) shall be deemed to be acceptable. Inspection shall not reveal any damage to the adaptor which would impair its safety within the requirements of this standard.

Á

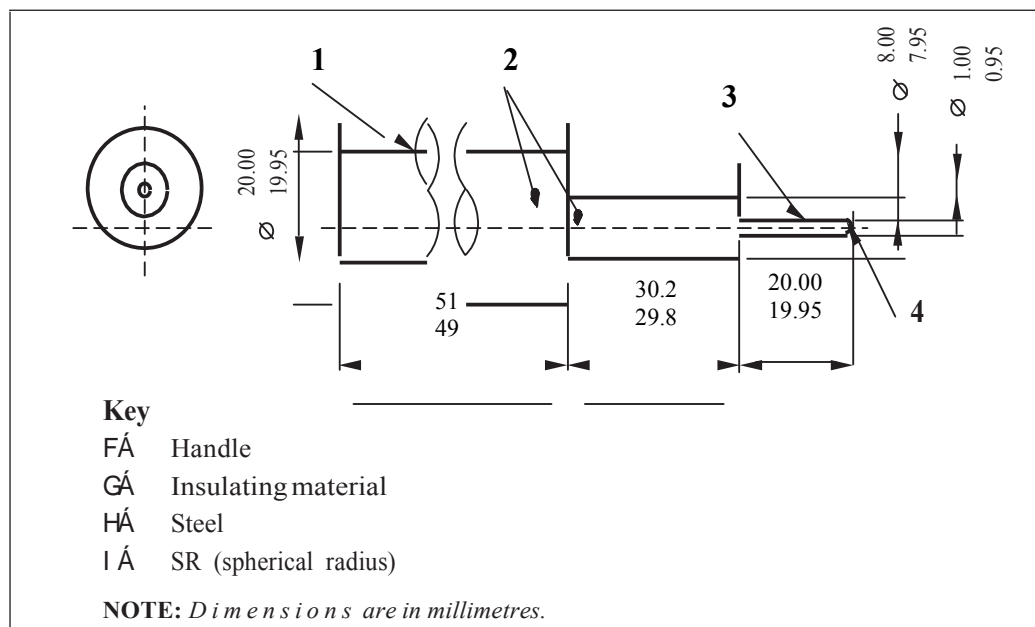


FIGURE 1 - Test pin (see 9)

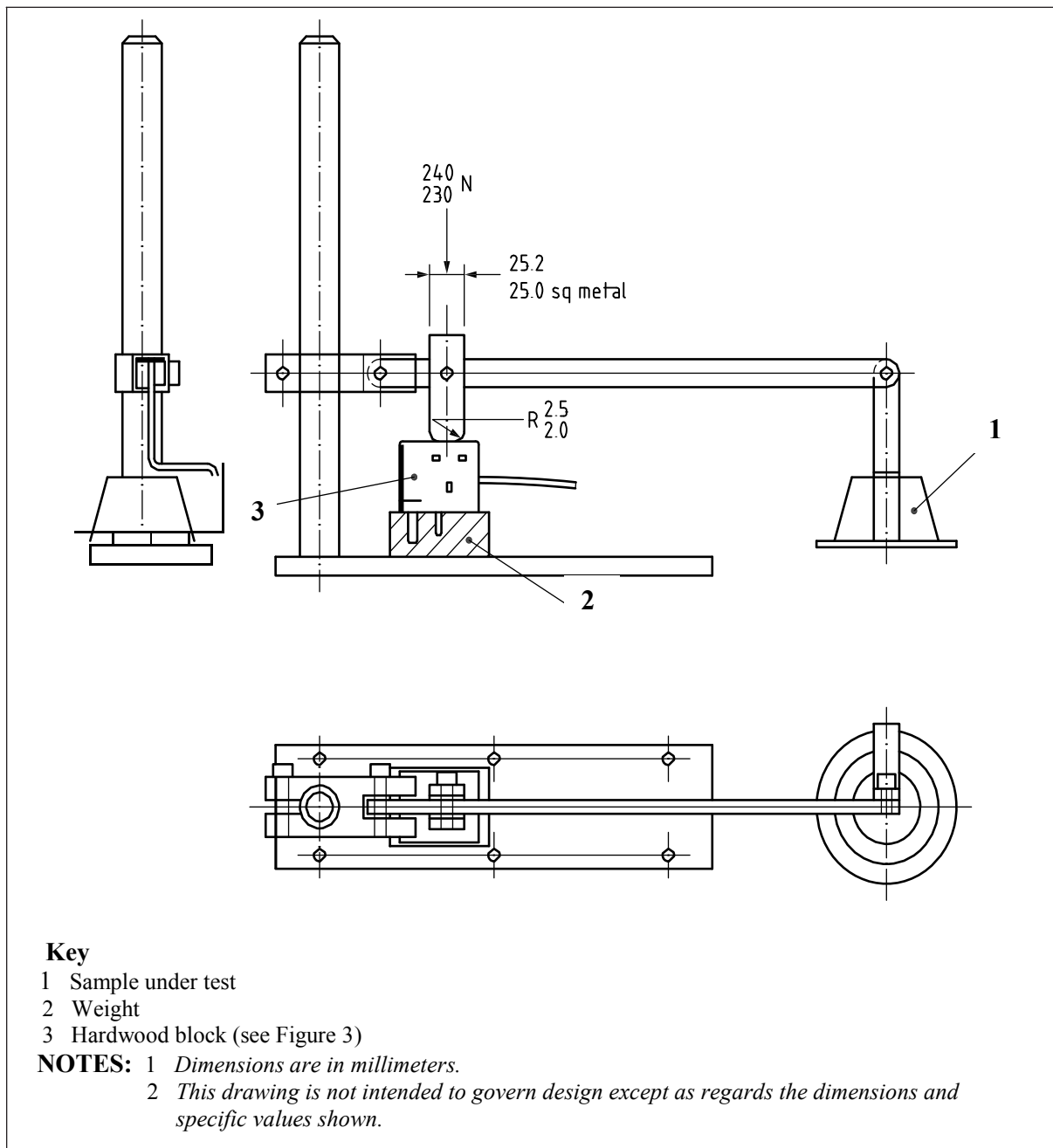


FIGURE 2 – Apparatus for mechanical strength test on resilient covers (see 9)

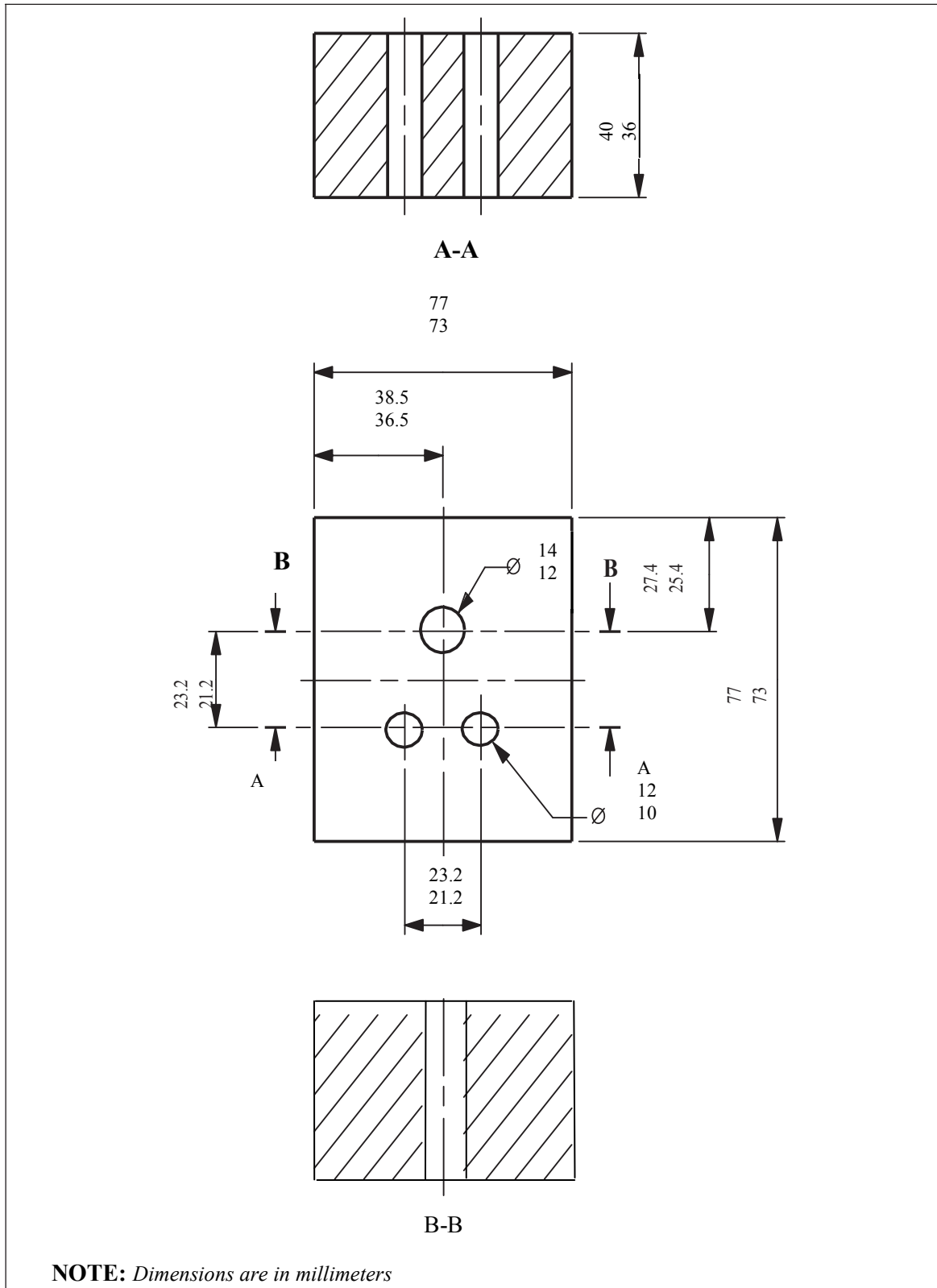


FIGURE 3 - Hardwood block for Figure 2 (see 9)

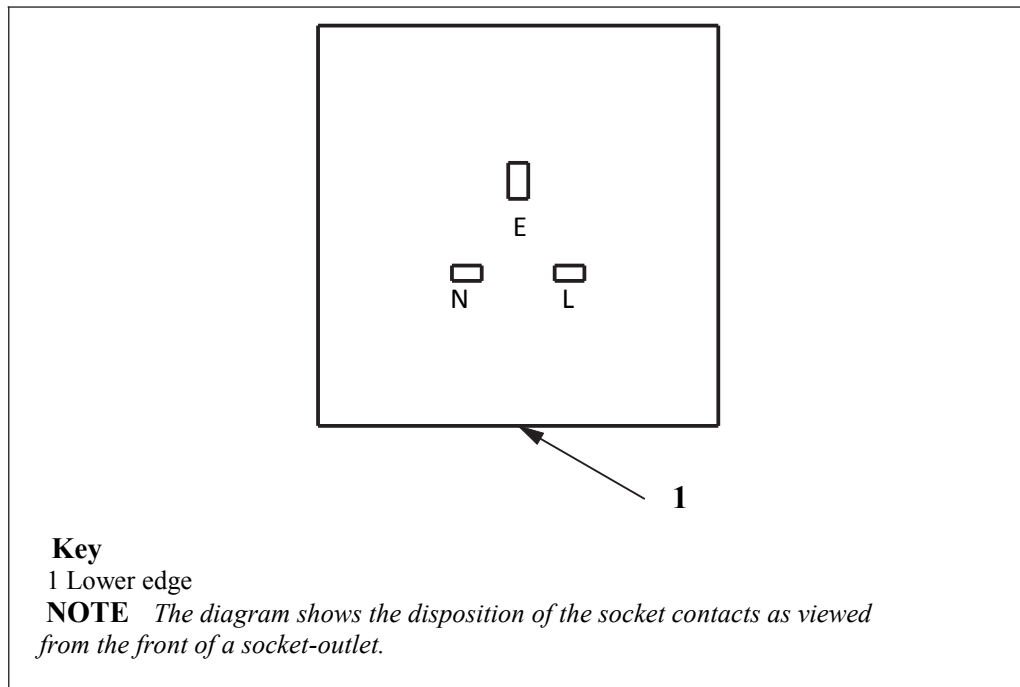


FIGURE 4 - Disposition of socket contacts (see 13)

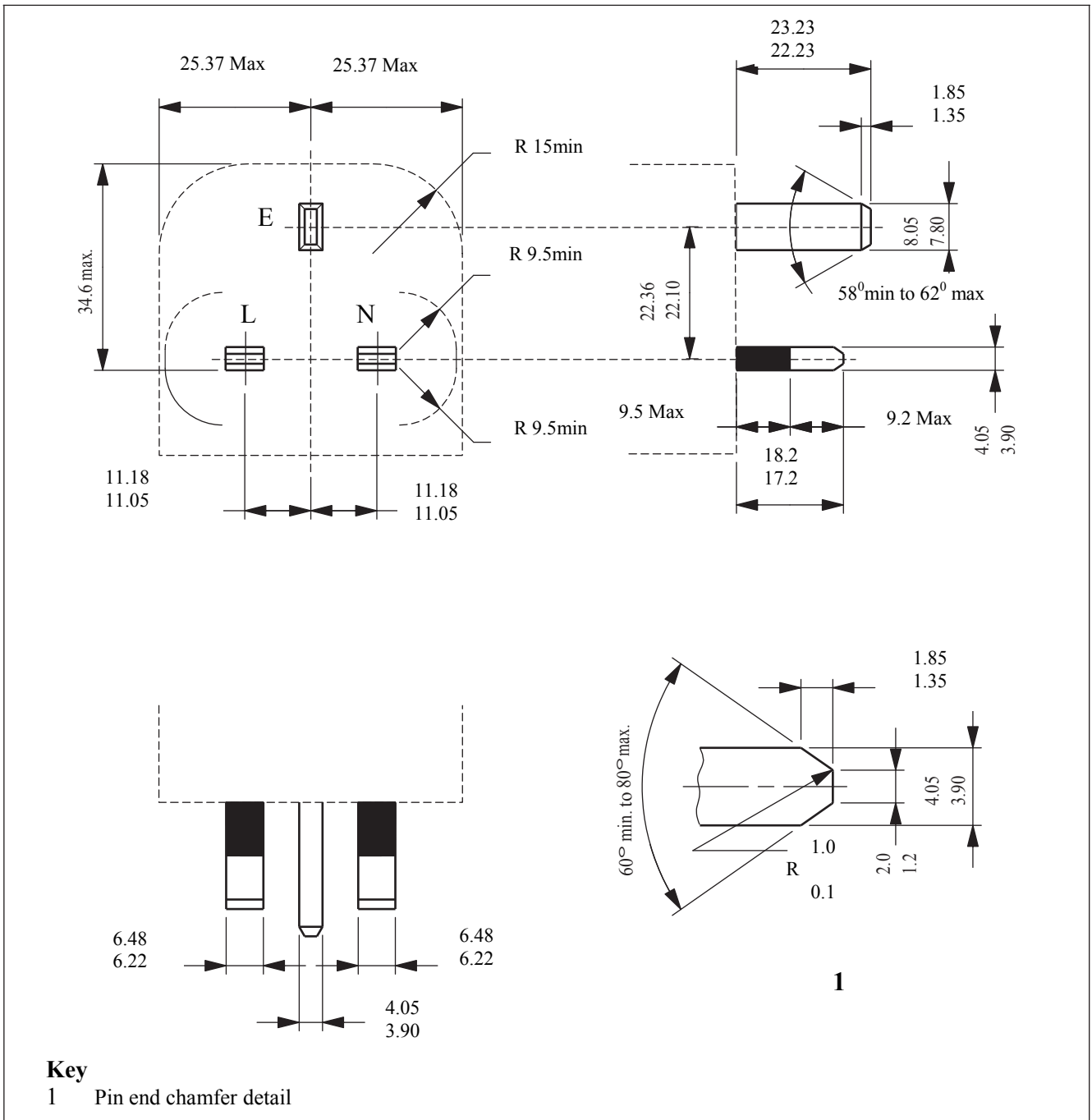


FIGURE 5 - Dimensions and disposition of pins (see 12) (Continued)

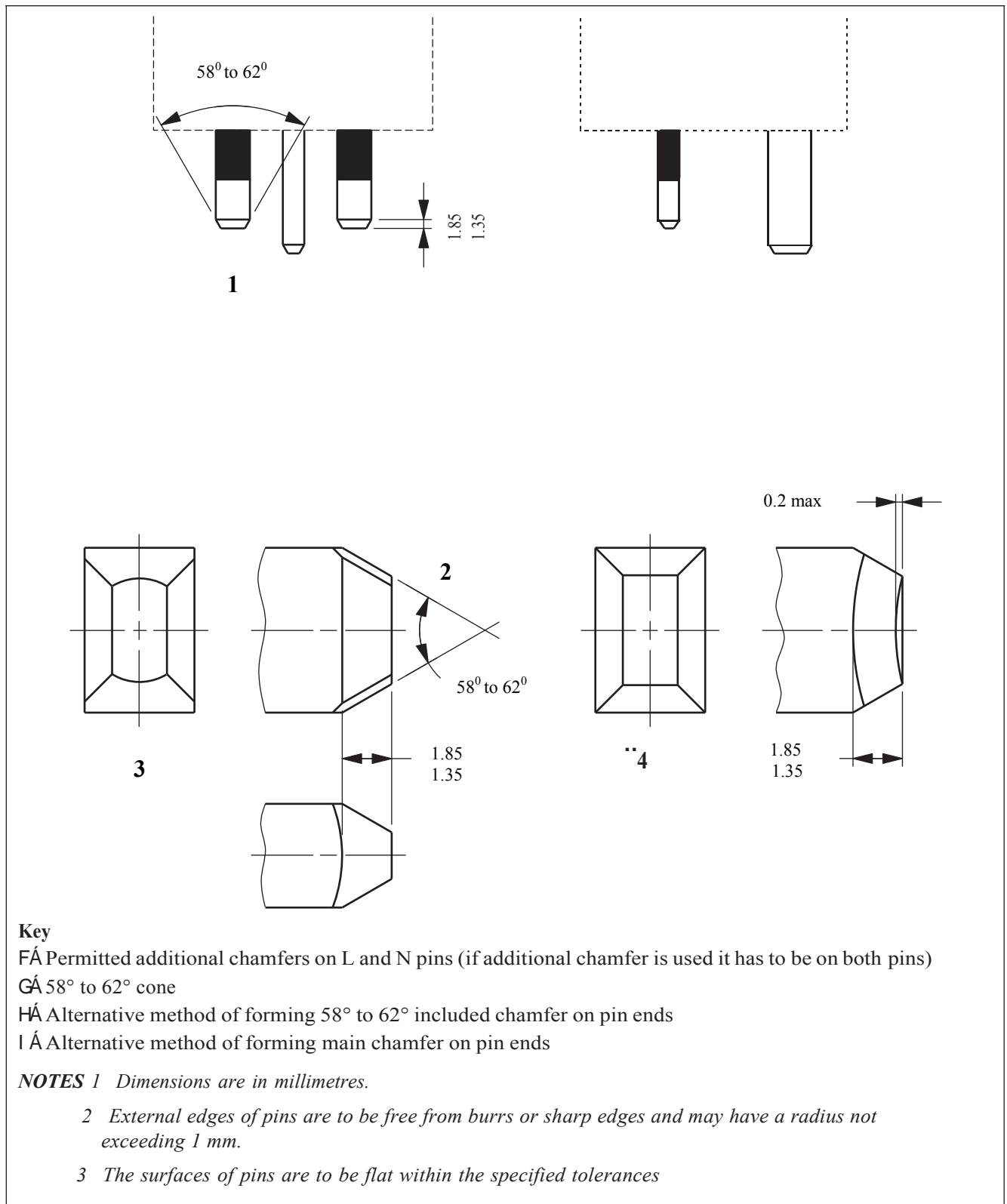
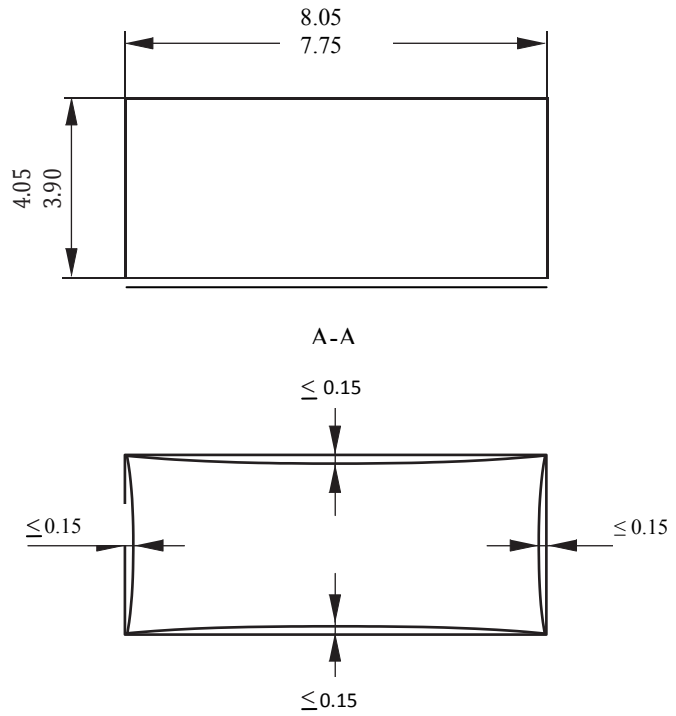
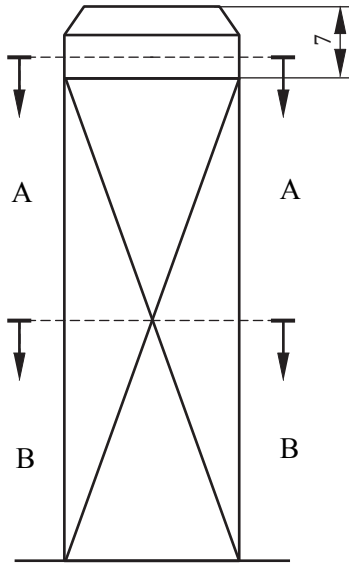
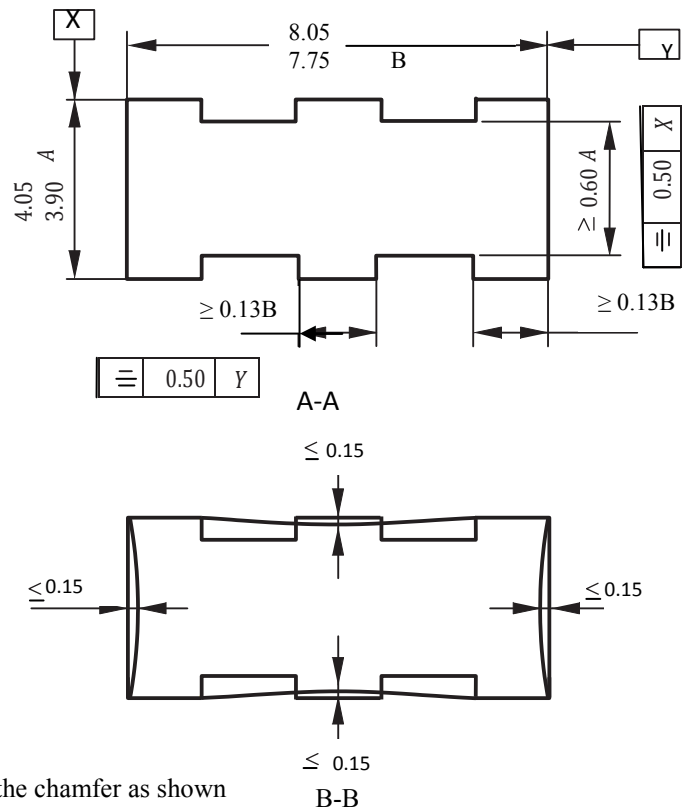
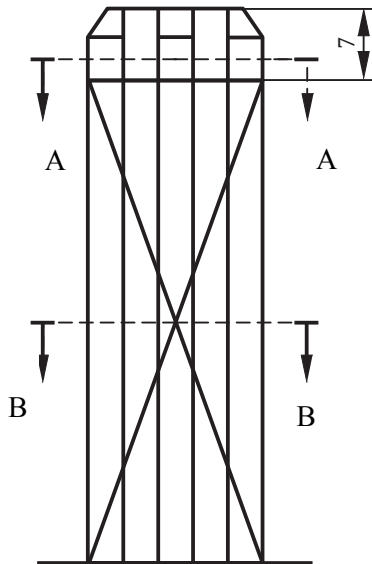


FIGURE 5 - Dimensions and disposition of pins (see 12) (Concluded)


 Solid ISOD



Castellated ISOD



NOTES

- 1 Dimensions are in millimeters.
- 2 Section A-A to be measured away from the chamfer as shown

FIGURE 6 – Concave shrinkage allowances for ISOD (see 12)

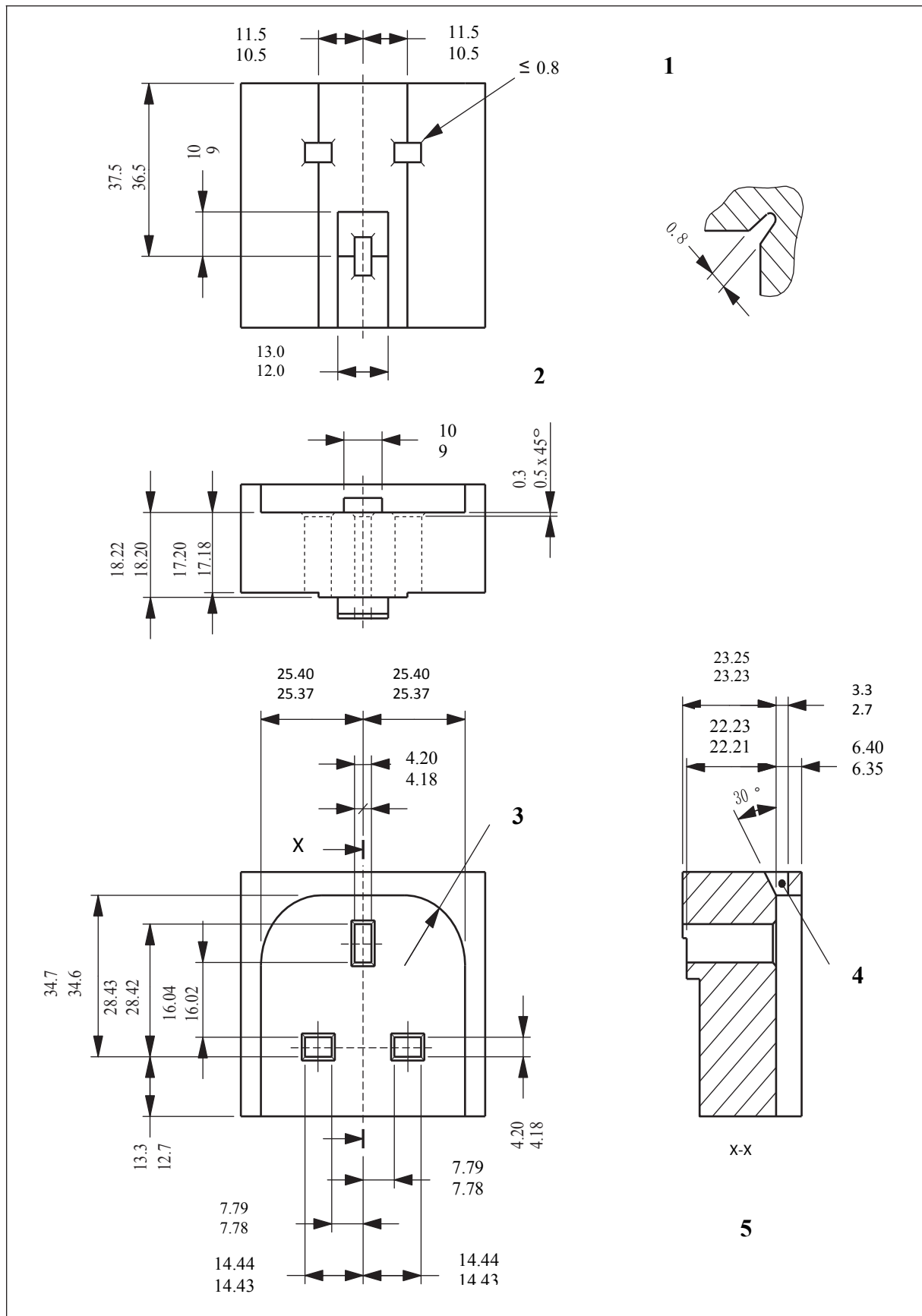
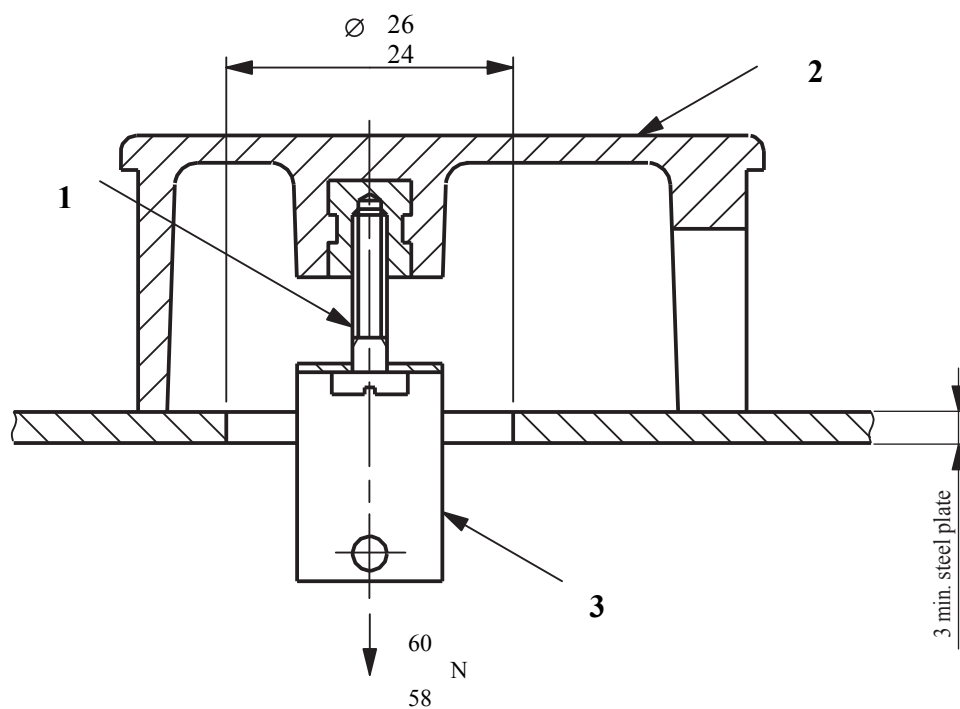


FIGURE 7 - Gauge for plug pins (see 12, 20 and 22) (Continued)**Key**

- FÁ Corners may be relieved up to width of 0.8 as shown
 GÁ Chamfer all round
 HÁ Radius =15.088 TP (true profile) with a tolerance zone 0.100 wide, ± 0.050 from the TP; the form of this contour is to blend smoothly with the sides
 IÁ Slot optional
 ÍÁ Gauge may be fabricated in several component parts, providing assembly is within dimensions shown

NOTE Dimensions are in millimetres.

FIGURE 7 - Gauge for plug pins (see 12, 20 and 22) (Concluded)**KEY**

- 1 Cover retaining screw positioned as in service
 2 Sample plug/adaptor cover supported with cover fixing screw axis vertical
 3 Light metal stirrup

NOTES 1 Dimensions are in millimeters.

2 This drawing is not intended to govern design, except as regards the dimensions and specific requirement shown.

FIGURE 8 - Apparatus for testing plug cover fixing screws (see 12)

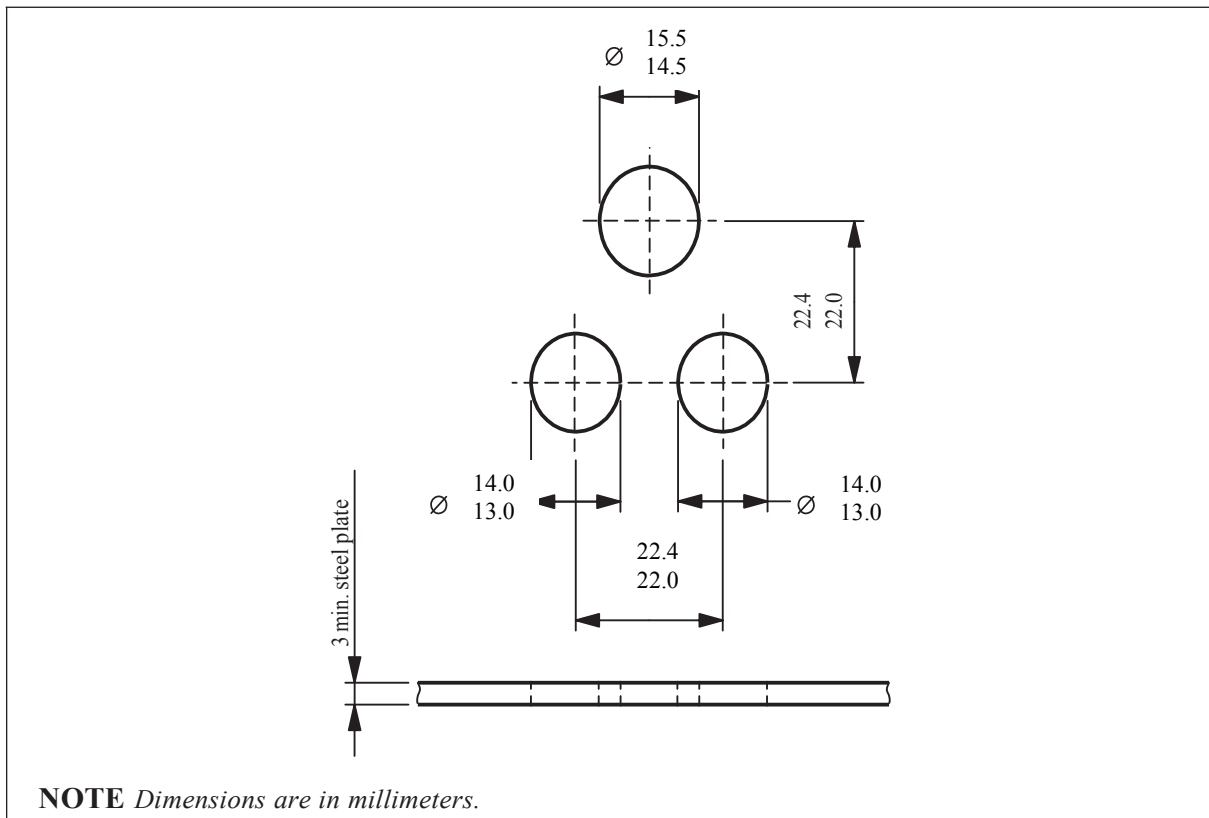


FIGURE 9 - Mounting plate (see 12)

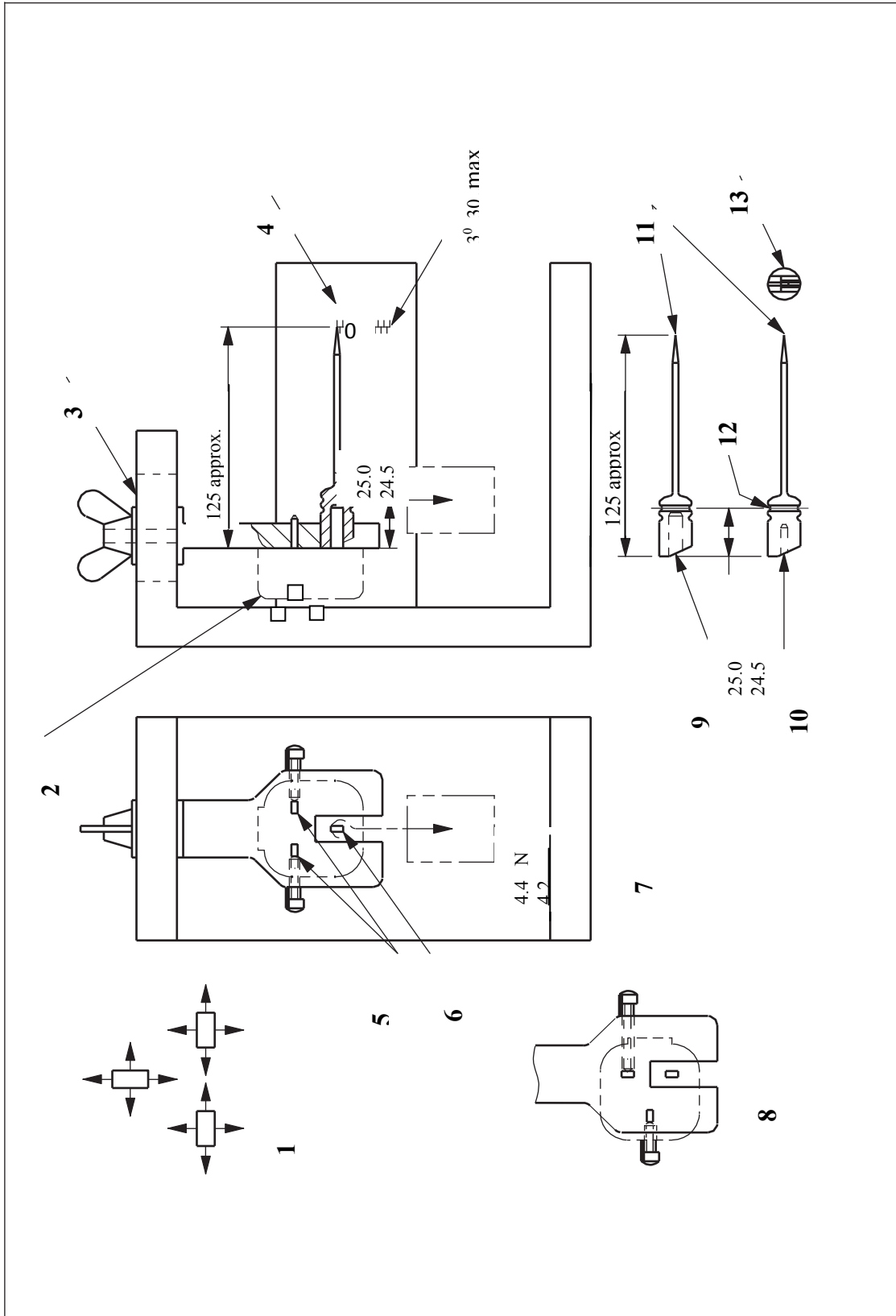


FIGURE 10 – Plug pin deflection test apparatus for resilient adaptors (see 12) (Continued)

Key	
1	Shape of plug mounting block should allow for the direction of pull when measuring deflection of pins as shown in diagram
2	Back of adaptor should not be supported or come into contact with fixture
3	Mounting block clamped in slot which gives adjustment to allow for various adaptors
4	Zero on scale = horizontal axis of pin under test
5	Clamped pins
6	Pin under test for deflection measurement
7	Elevation of fixture shows disposition of adaptor pins for deflection test on earth pin
8	Diagrams show disposition of adaptors pins in typical mounting block for deflection test on current-carrying pins
9	Spring fit on to earth pin or ISOD
10	Spring fit on current-carrying pin
11	Indicating point
12	Groove for weight
13	Slot to ensure spring fit
NOTES:	
1	<i>Dimensions are in millimeters.</i>
2	<i>This drawing is not intended to govern design, except as regards the dimensions and specific and requirements shown.</i>
3	<i>Indicators manufactured from material of negligible weight, such as aluminium</i>

FIGURE 10 – Plug pin deflection test apparatus for resilient adaptors (see 12) (Concluded)

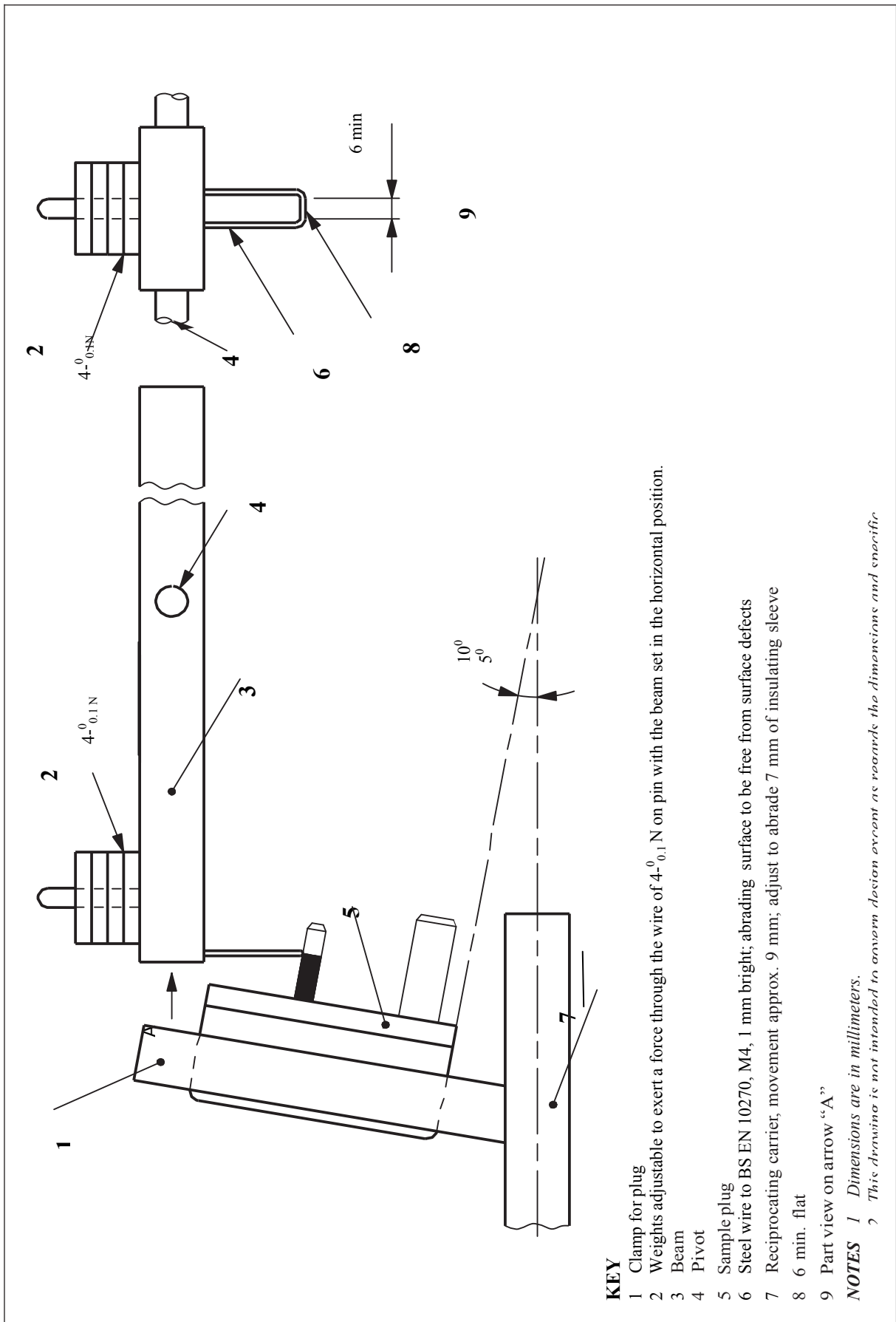


FIGURE 11 - Apparatus for abrasion test insulating sleeves of plug pins (see 12)

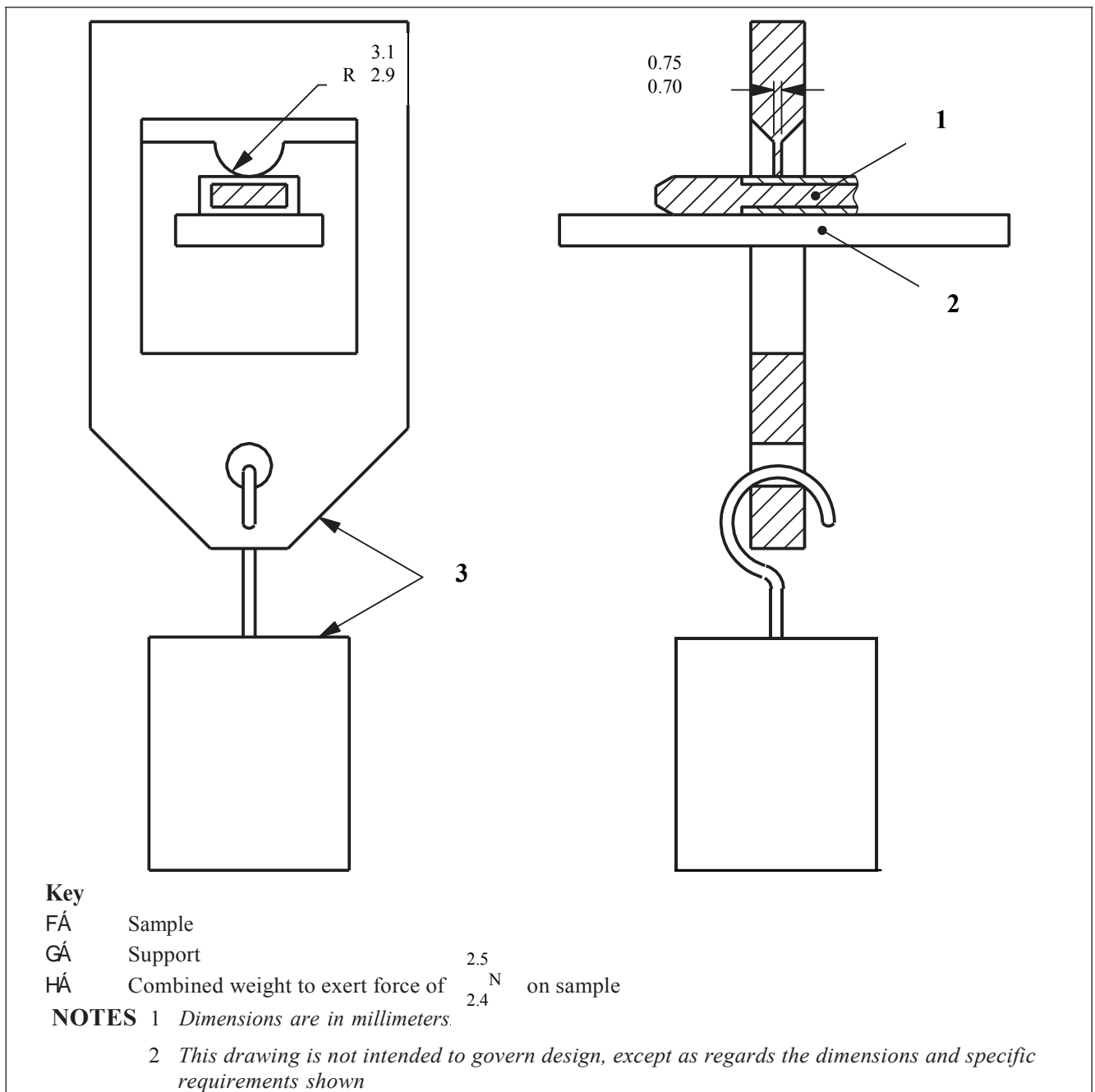


FIGURE 12 - Apparatus for Pressure test at high temperature (see 12)

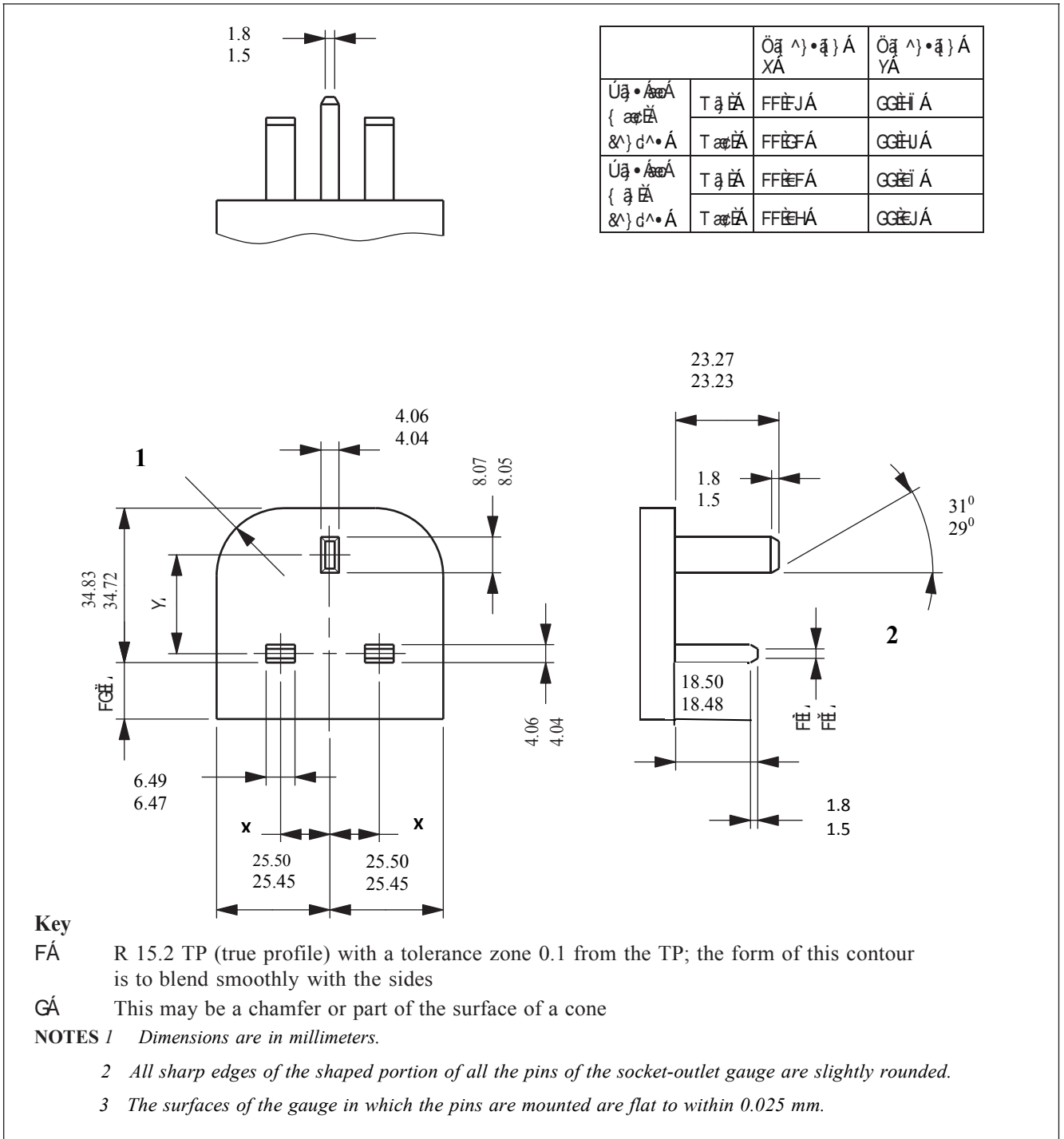


FIGURE 13 – GO gauge for socket outlet (see 13)

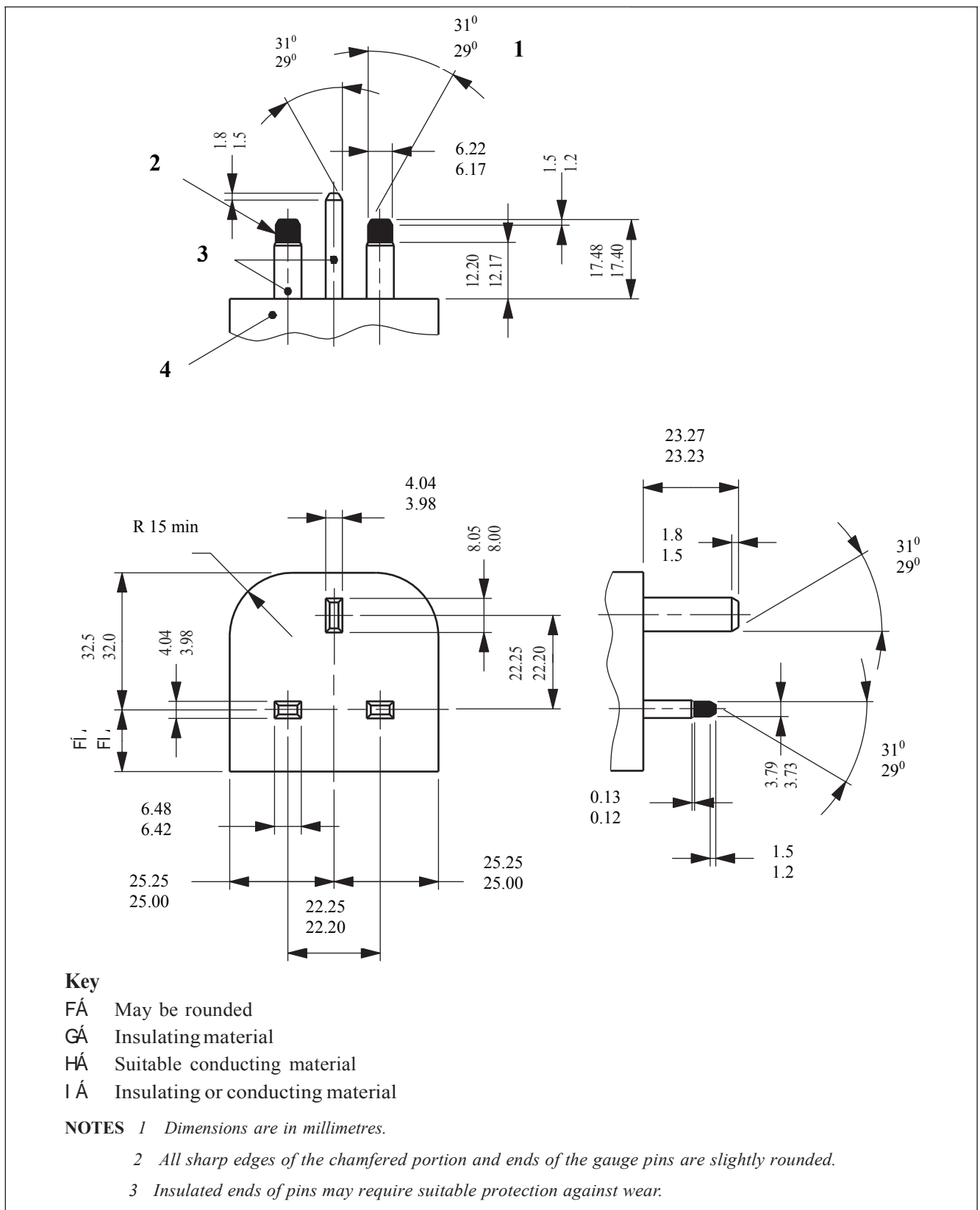


FIGURE 14 – Contact test gauge (see 13)

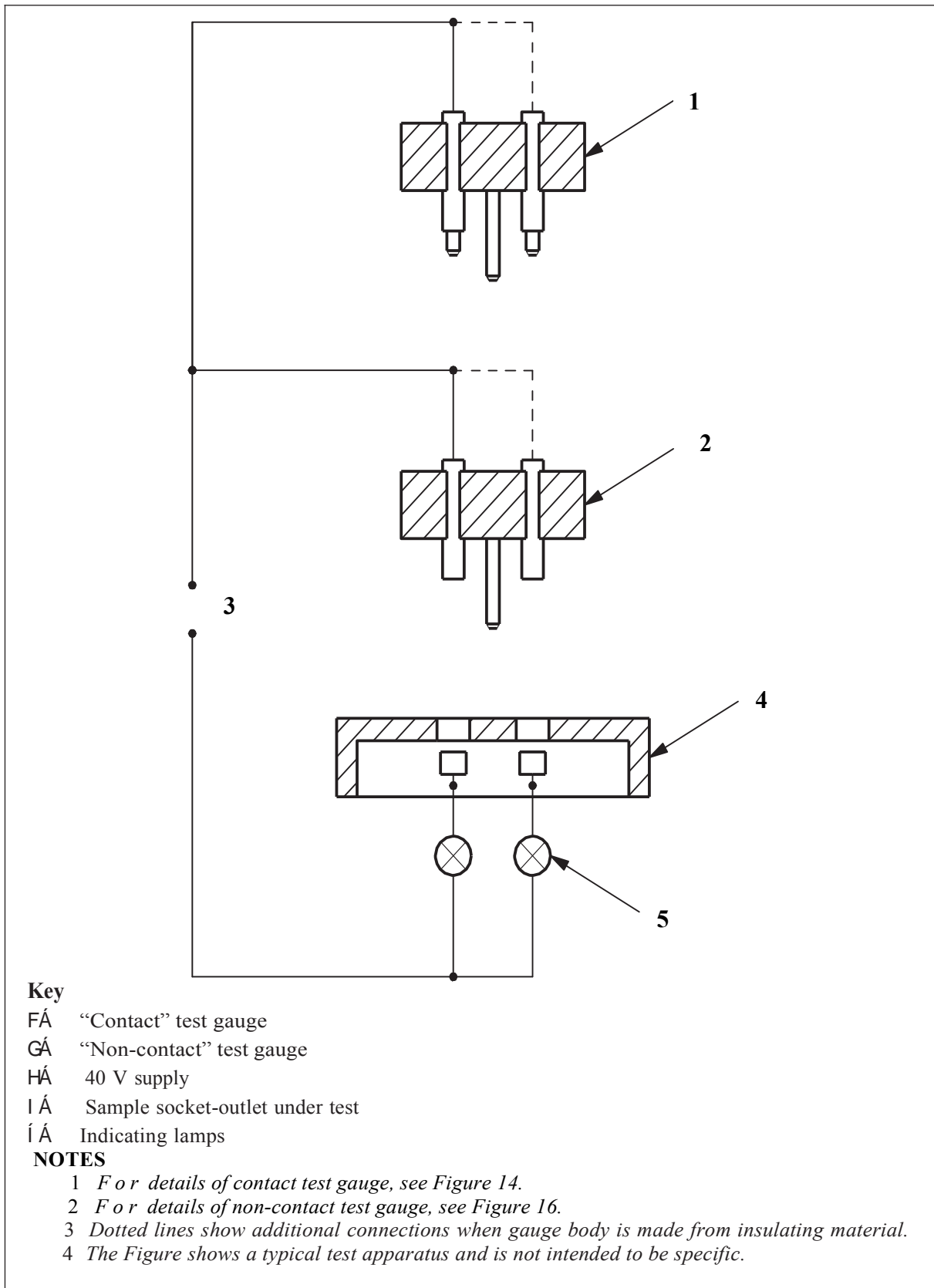


FIGURE 15 - Test apparatus and circuit for use with contact and non-contact gauges (see 13)

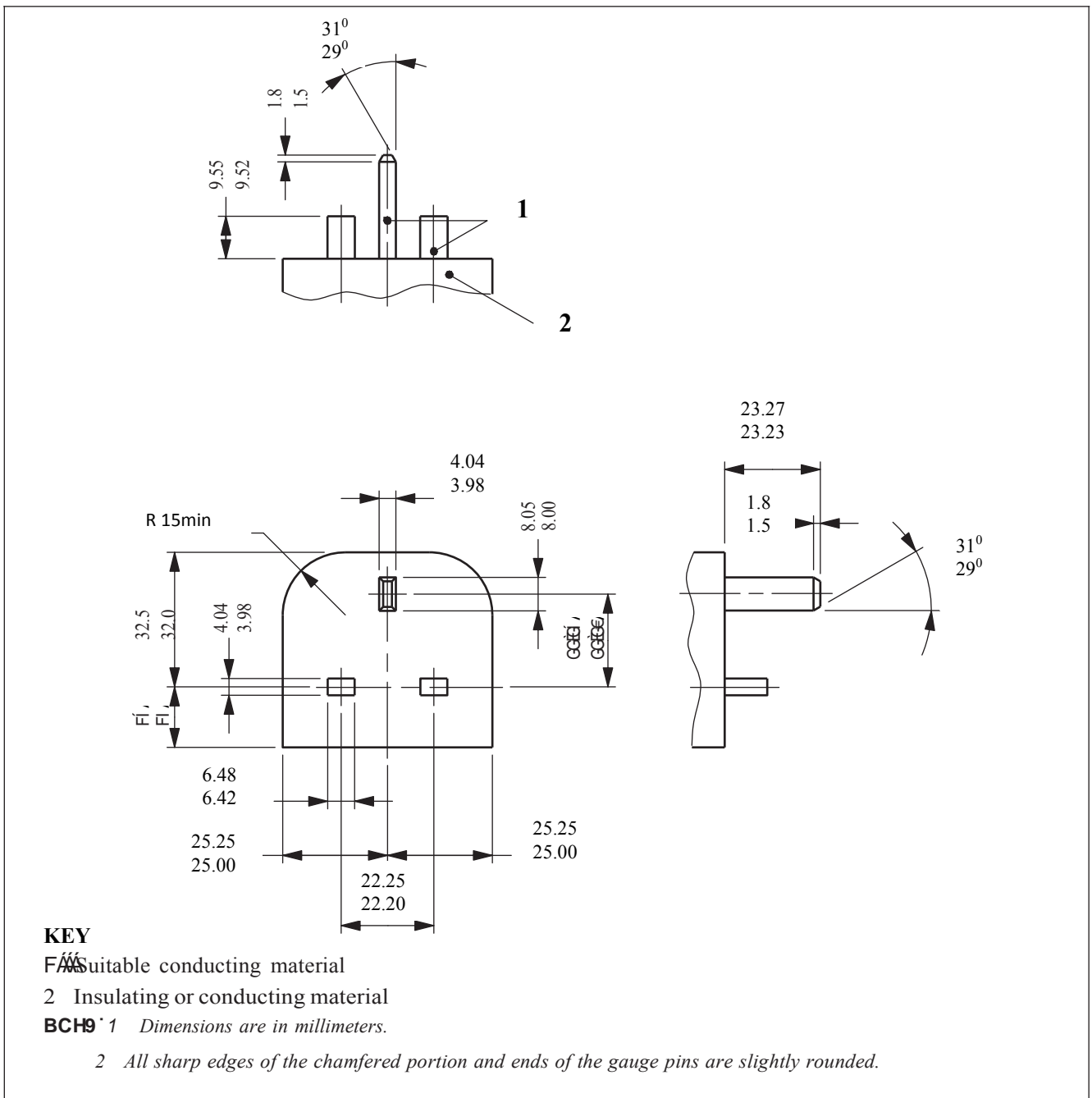


FIGURE 16 – Non-Contact test gauge (see 5)

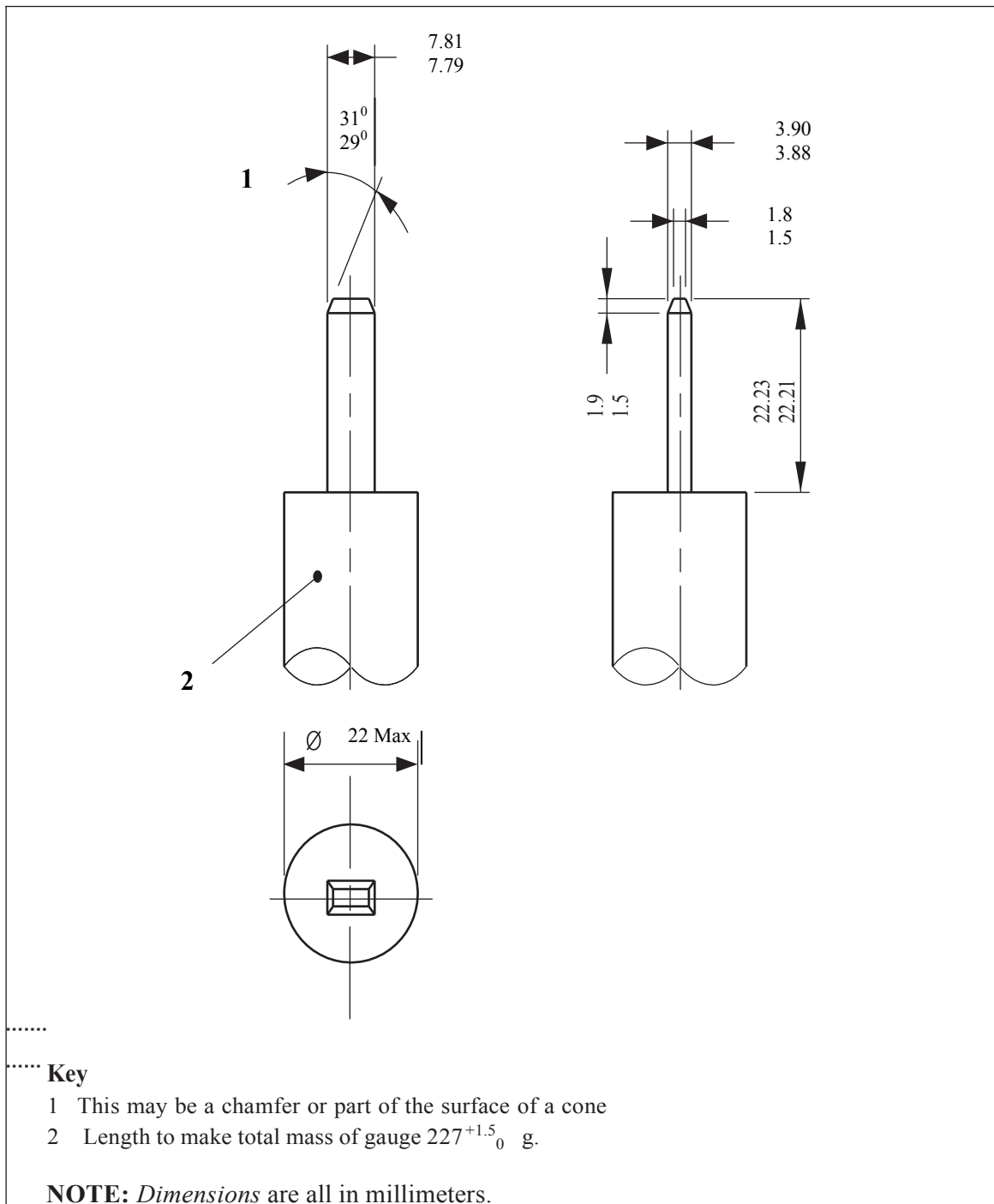


FIGURE 17a – Withdrawal pull gauges for effectiveness of contact: Gauge for earthing socket contact (see 13)

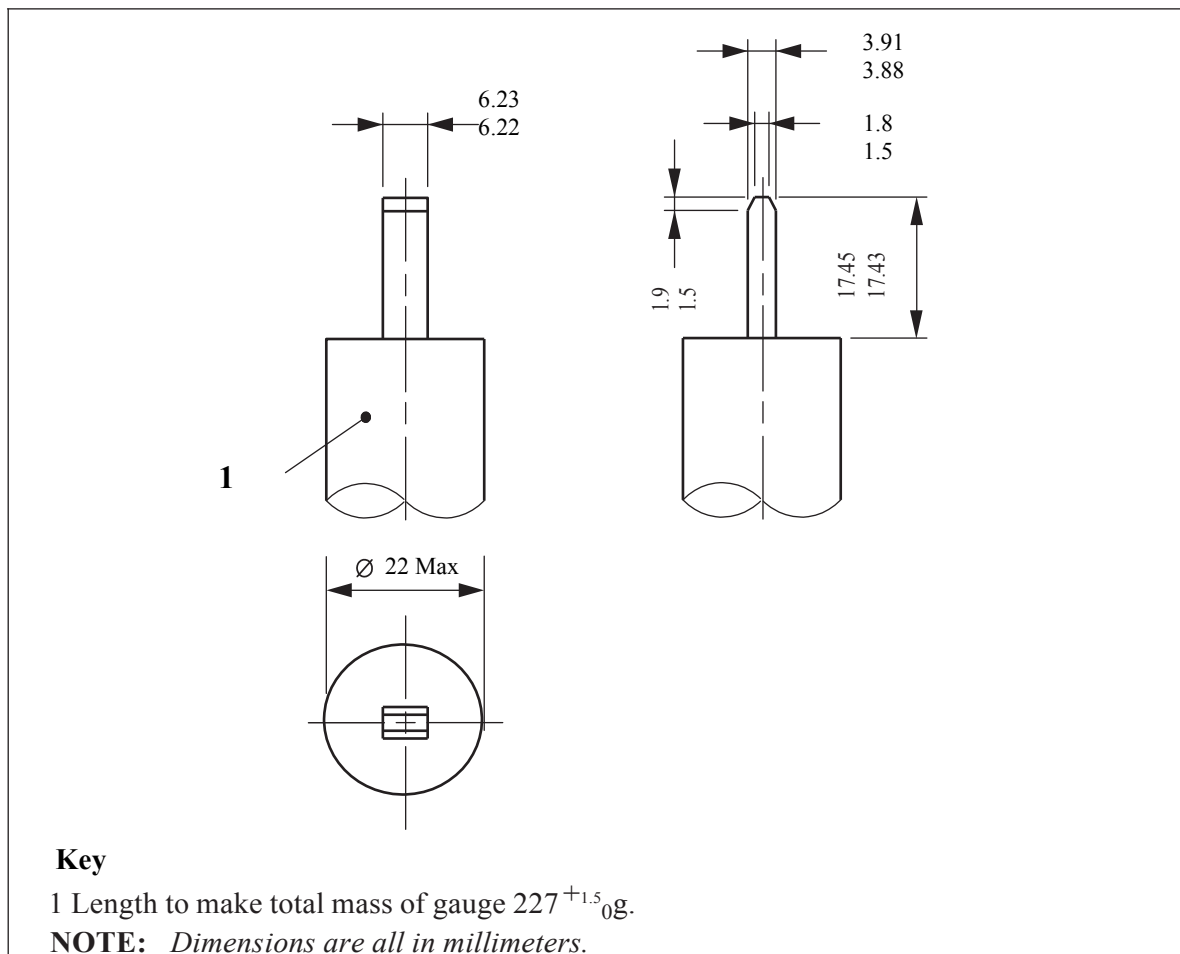
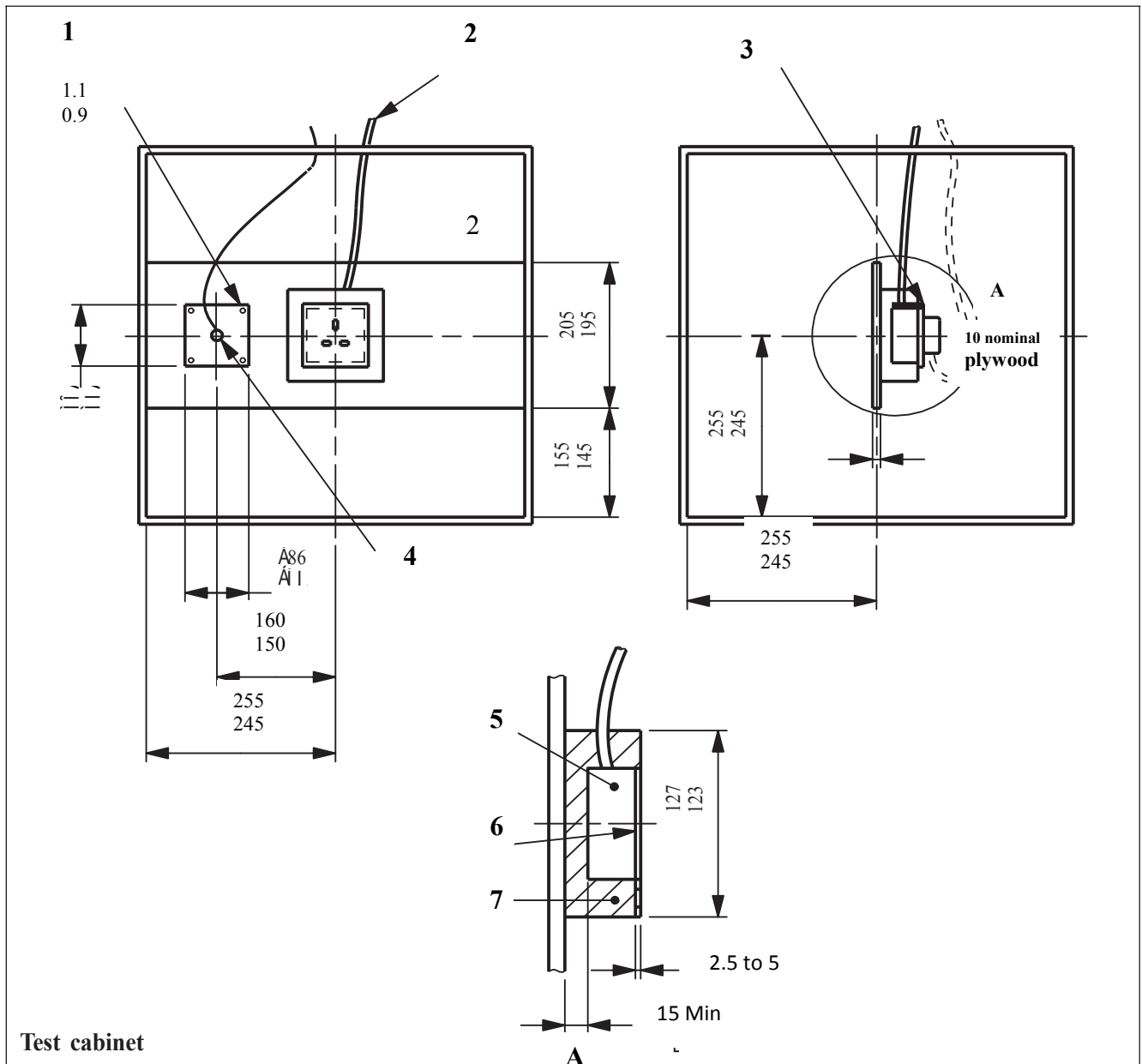


FIGURE 17b – Withdrawal pull gauges for effectiveness of contact: Gauge for line and neutral current carrying socket contact (see 13)



Test cabinet

- Material: 10 mm nominal plywood.
- Finish: Internal. Two coats of matt paint. BS 4800:2011, colour no. 08 C 35.
- Dimensions: Internal. (500 × 500 × 500) mm with a tolerance of ±10 mm for each dimension. One wall to be removable to provide access.
- Location: Minimum clearance from adjacent surfaces, measured horizontally 150 mm on all sides, measured vertically 300 mm above, 500 mm below.

Key

- 1 Brass plate ^{1.1}_{0.9} mm thick screwed to plywood board
- 2 Cable and thermocouple wire outlet to be sealed
- 3 Plate as Figure 19)
- 4 Thermocouple for reference point temperature
- 5 Mounting box to SLS 1310, Figure 1, 35 mm deep (nominal)
- 6 Front edge recessed as shown
- 7 Wooden mounting block

NOTE: Dimensions are all in millimeters

FIGURE 18 – Test apparatus for temperature rise test (see 16)

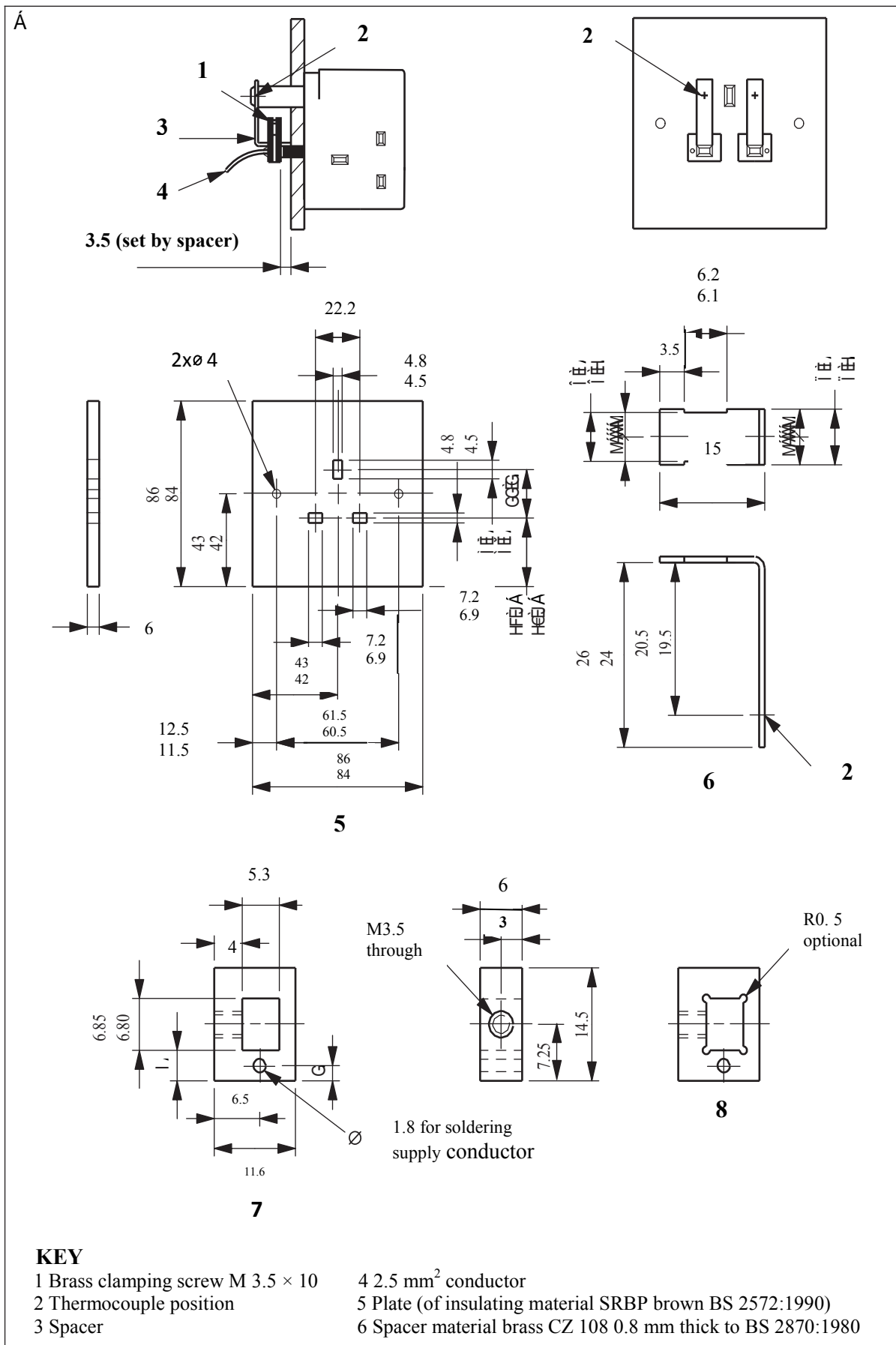


FIGURE 19 – Dummy front plate for temperature rise test (see 16) (Continued)

7 Clamp, material brass

8 Optional alternative clamp

NOTES: 1 *Dimensions are in millimeters.*2 *Tolerance ± 0.2 mm except where otherwise shown.*

* The positional tolerance of the three pin apertures shall be proved by the use of gauges in accordance with Figure 13.

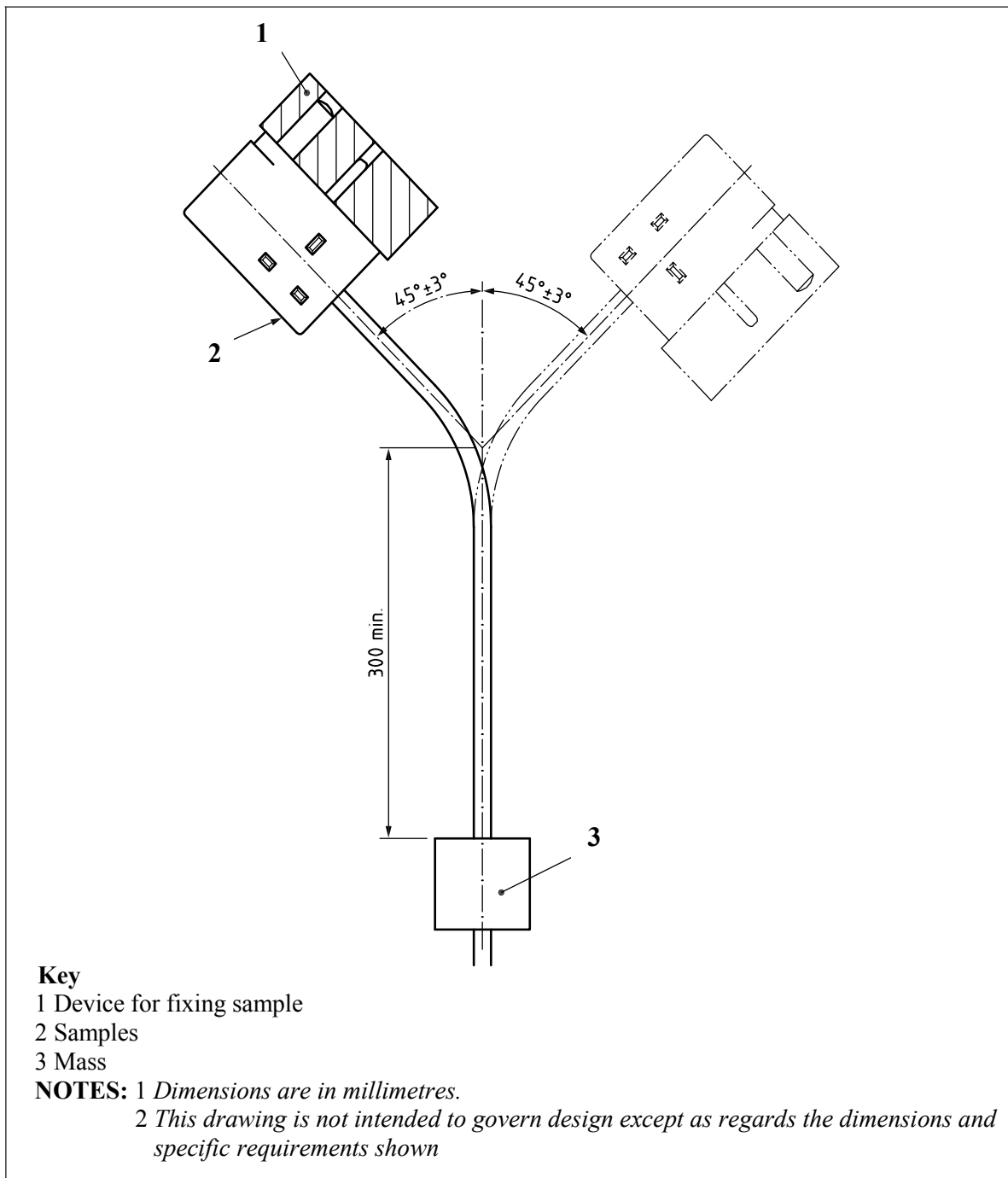
FIGURE 19 – Dummy front plate for temperature rise test (see 16) (Concluded)

FIGURE 20 –Apparatus for flexing test (see 19)

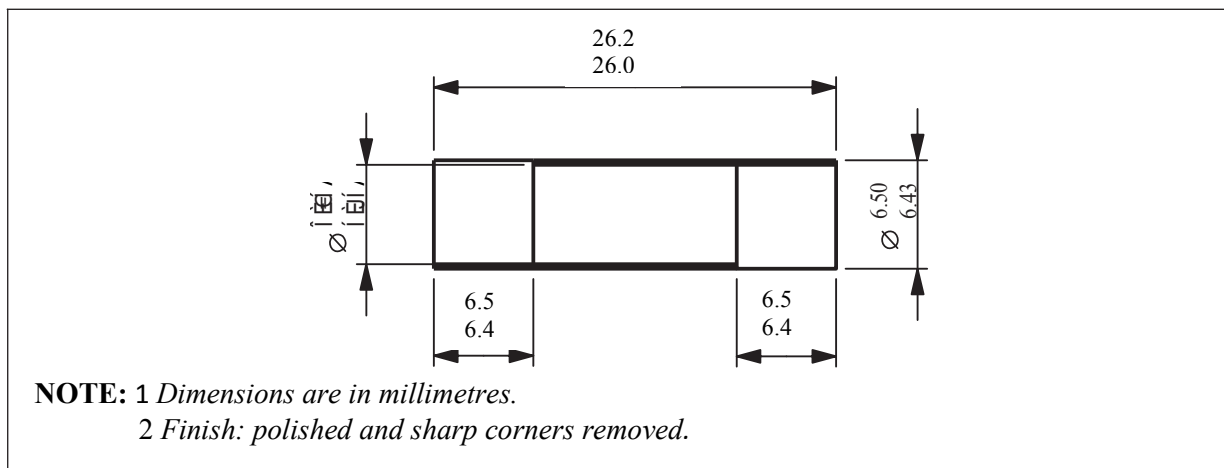


FIGURE 21 – Solid link for test on fuse clips

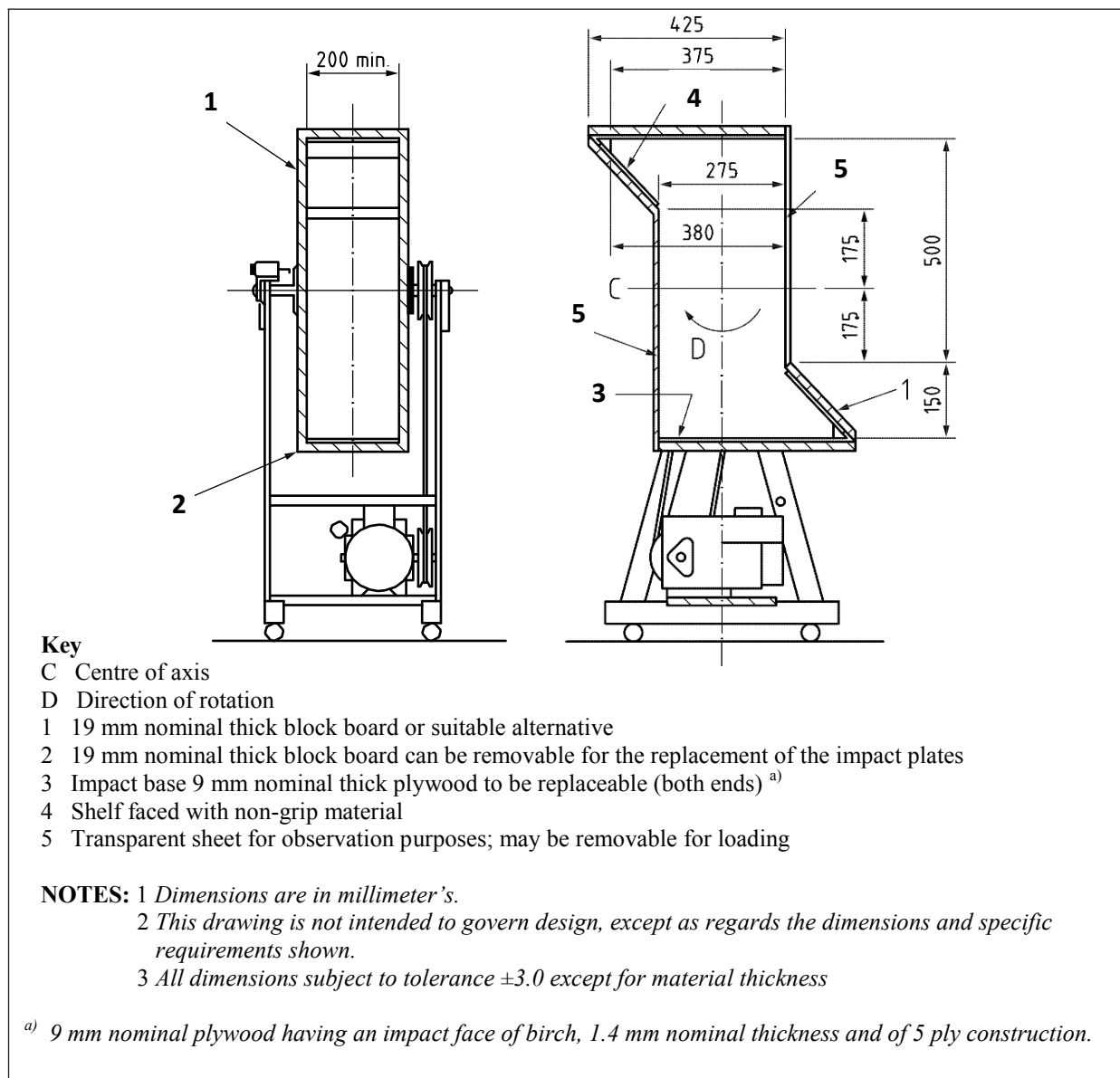


FIGURE 22 – Tumbling barrel (see 20)

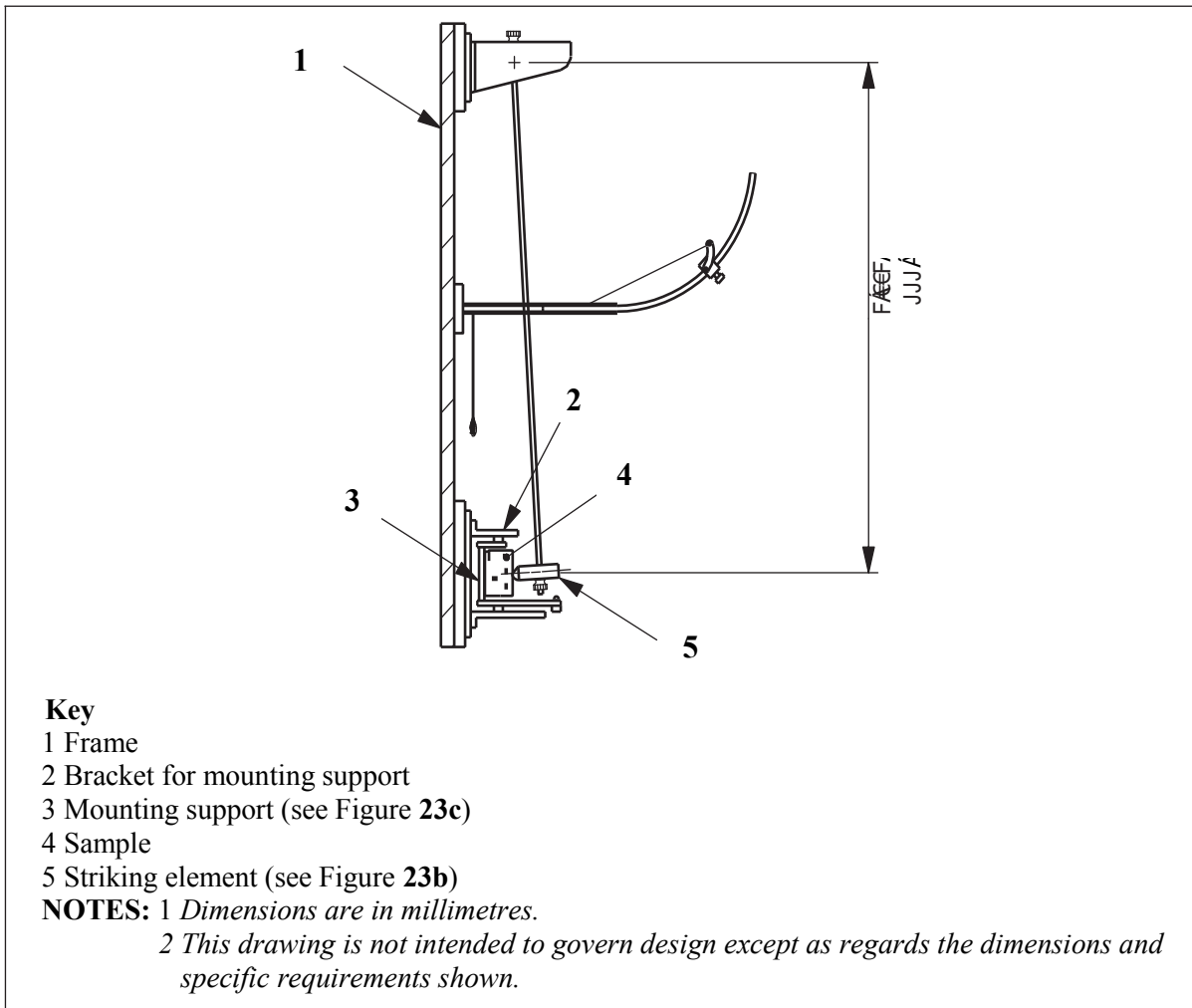


FIGURE – 23a Pendulum impact test: General view of apparatus (see 20)

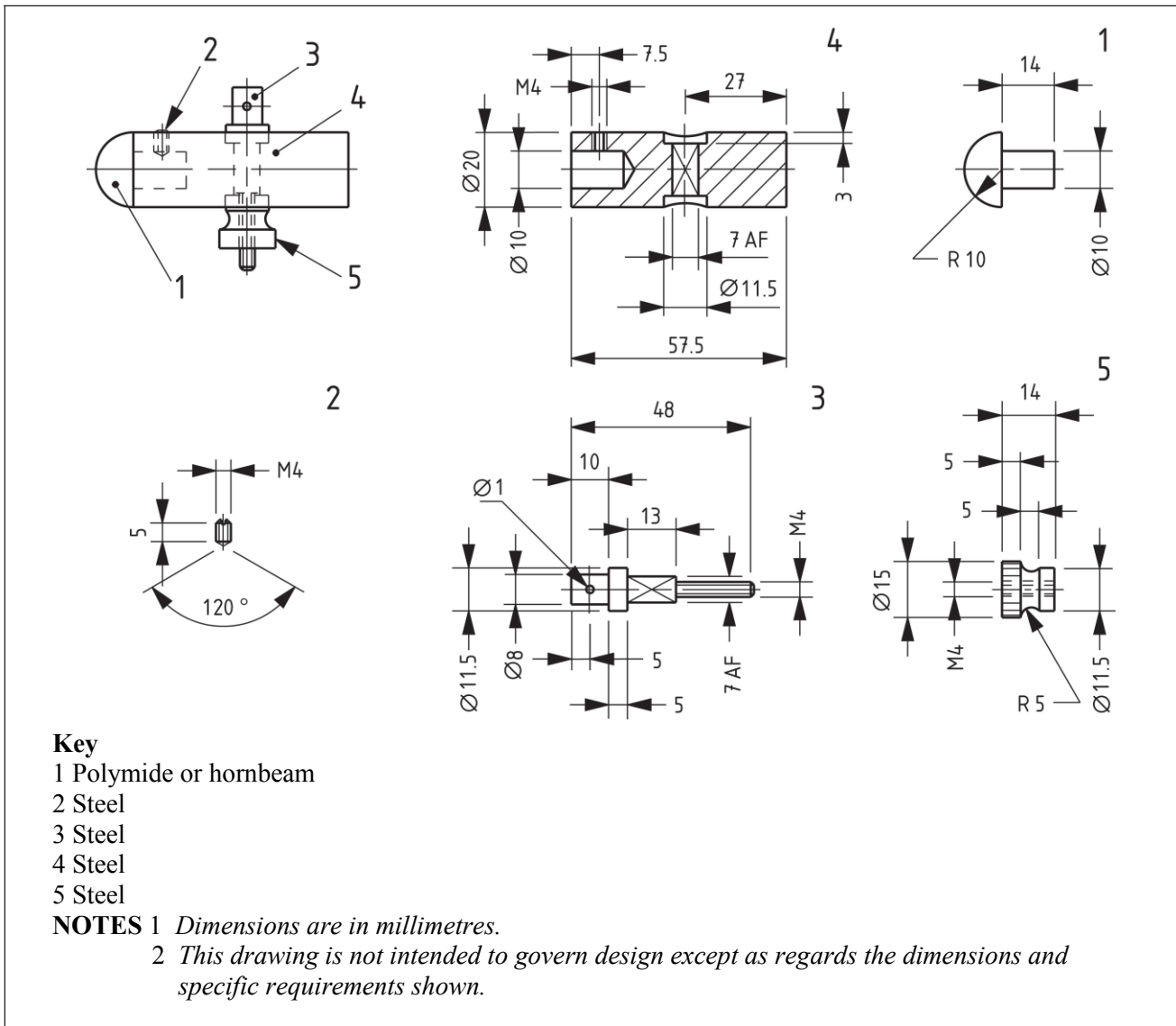


FIGURE 23b - Pendulum impact test: Constructional details of striking elements (see 20)

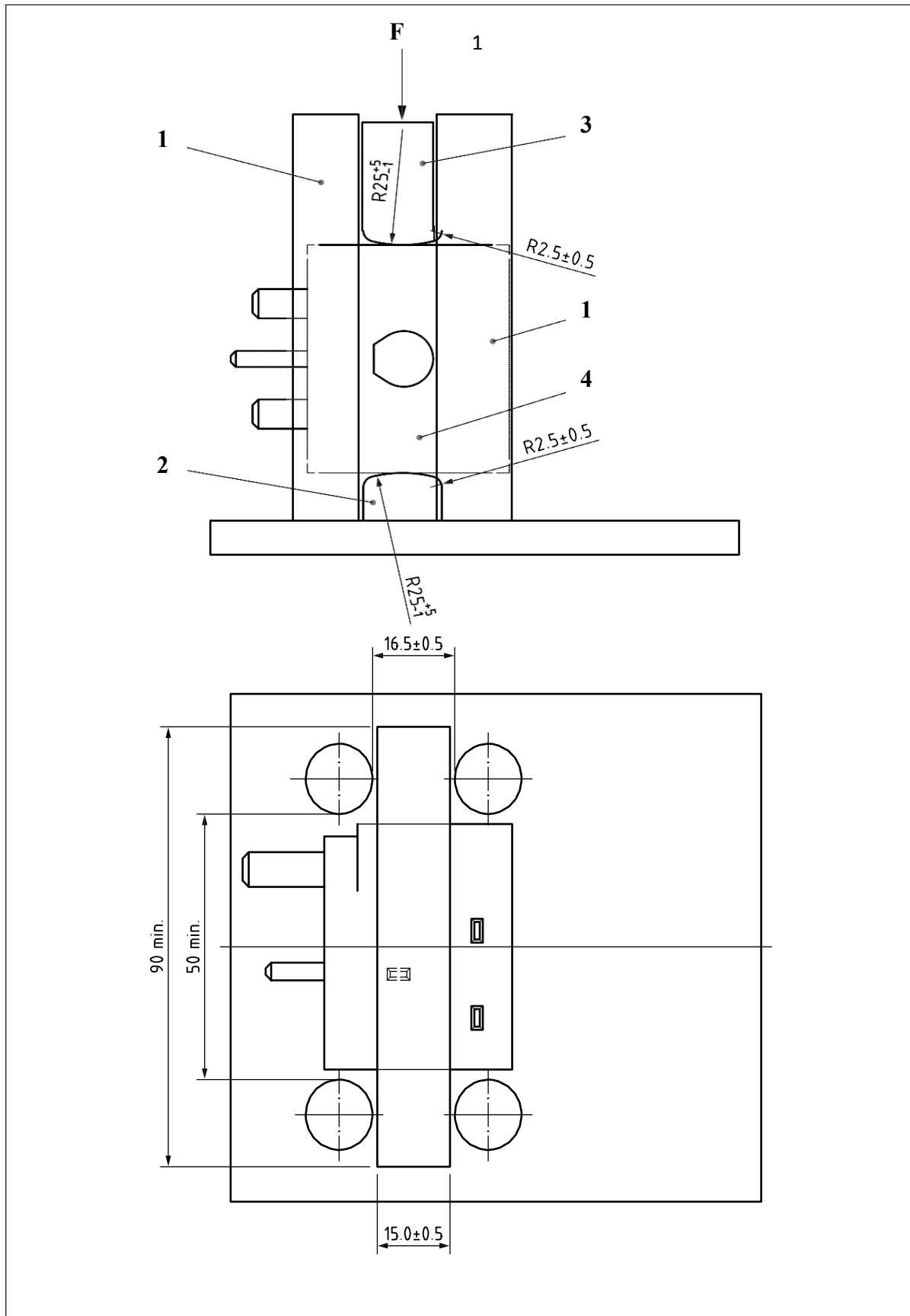


FIGURE 24 - Apparatus for pressure test (see 22) (Continued)

Key

F Force

1 Guide

2 Fixed jaw

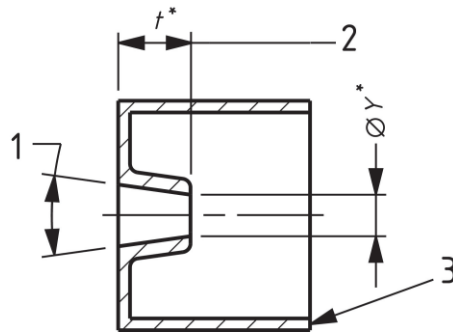
3 Moving jaw

4 Sample

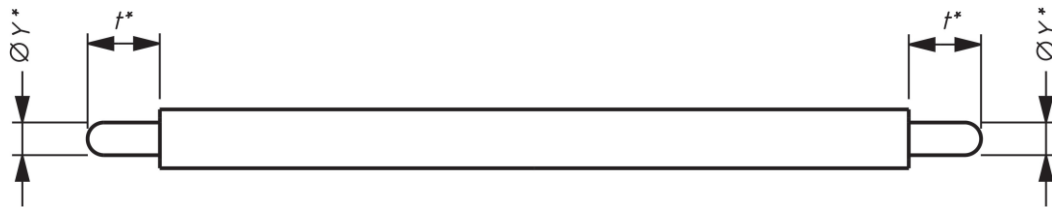
NOTES: 1 *Dimensions are in millimetres.*

2 *This drawing is not intended to govern design except as regards the dimensions and specific requirements shown.*

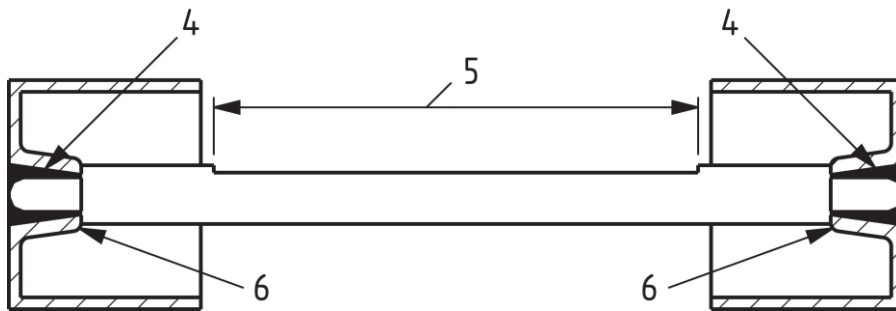
FIGURE 24 - Apparatus for pressure test (see 22) (Concluded)



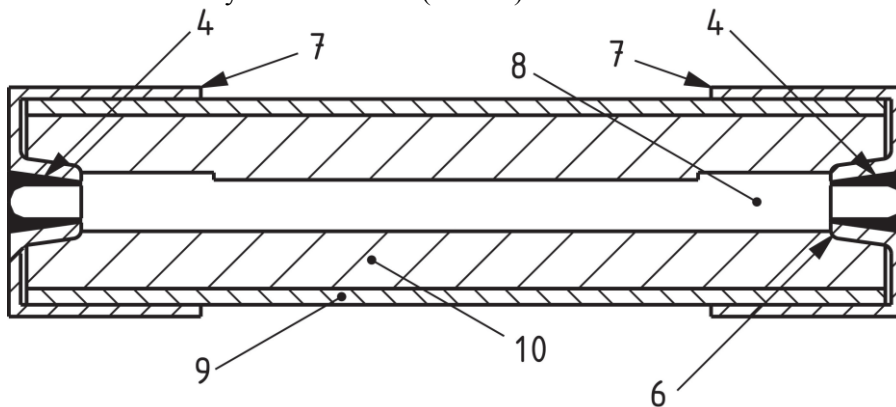
a) Modified standard end cap (section)



b) Calibrated link: Resistive element Cu Ni



c) Calibrated link: Assembly for calibration (section)



d) Calibrated link: Assembled link (section)

KEY

FÁ	Taper ream to facilitate soldering	6	End caps butt to element shoulders
GA	End wall thickness	7	End caps
HÁ	Hard-bright silver plated 0.025 thick	8	Resistive element
I Á	Solder	9	Standard ceramic tube
Í Á	Filing length for watt-loss adjustment	10	Standard filling

NOTE This drawing is not intended to govern design except as regards the dimensions and specific requirements shown. * See Annex A.

FIGURE 25 - Calibrated link (see Annex A)

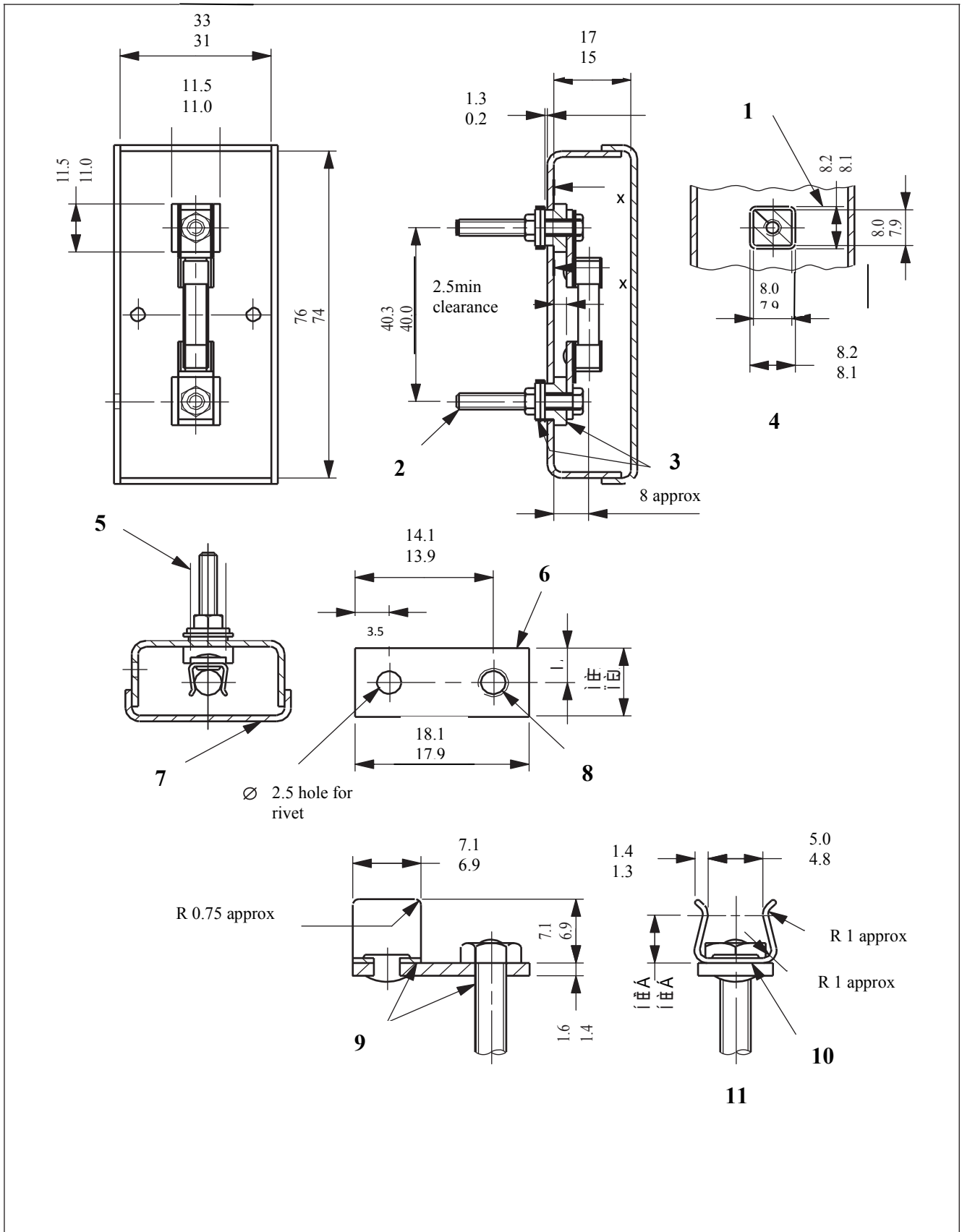


FIGURE 26 - Calibration jig for calibrated link (see Annex A) (Continued)

Key	
1 Float ^{a)}	7 Cover ^{b),c)}
2 Terminal stem M3 × 25	8 Hole tapped M3 for terminal stem
3 Insulating material	9 Joints between clip, contact plate and terminal stem to be soldered
4 Part section X-X ^{a)}	10 Fuse clip ^{d)}
5 Groove to fit contact plate	11 Contact assembly
6 Contact plate, brass	

^{a)} The end float and clearance between the insulation and the box is to allow the contacts to be self aligning.

^{b)} Box and cover made from 1.25 mm brass sheet, clean natural finish.

^{c)} Cover shall be a push fit on box and shall not be rigidly attached.

^{d)} Fuse clip made from beryllium copper 0.45 mm thick and heat treated (170 HV minimum). Base of clip to be flat; finish, silver plated.

FIGURE 26 - Calibration jig for calibrated link (see Annex A) (Concluded)

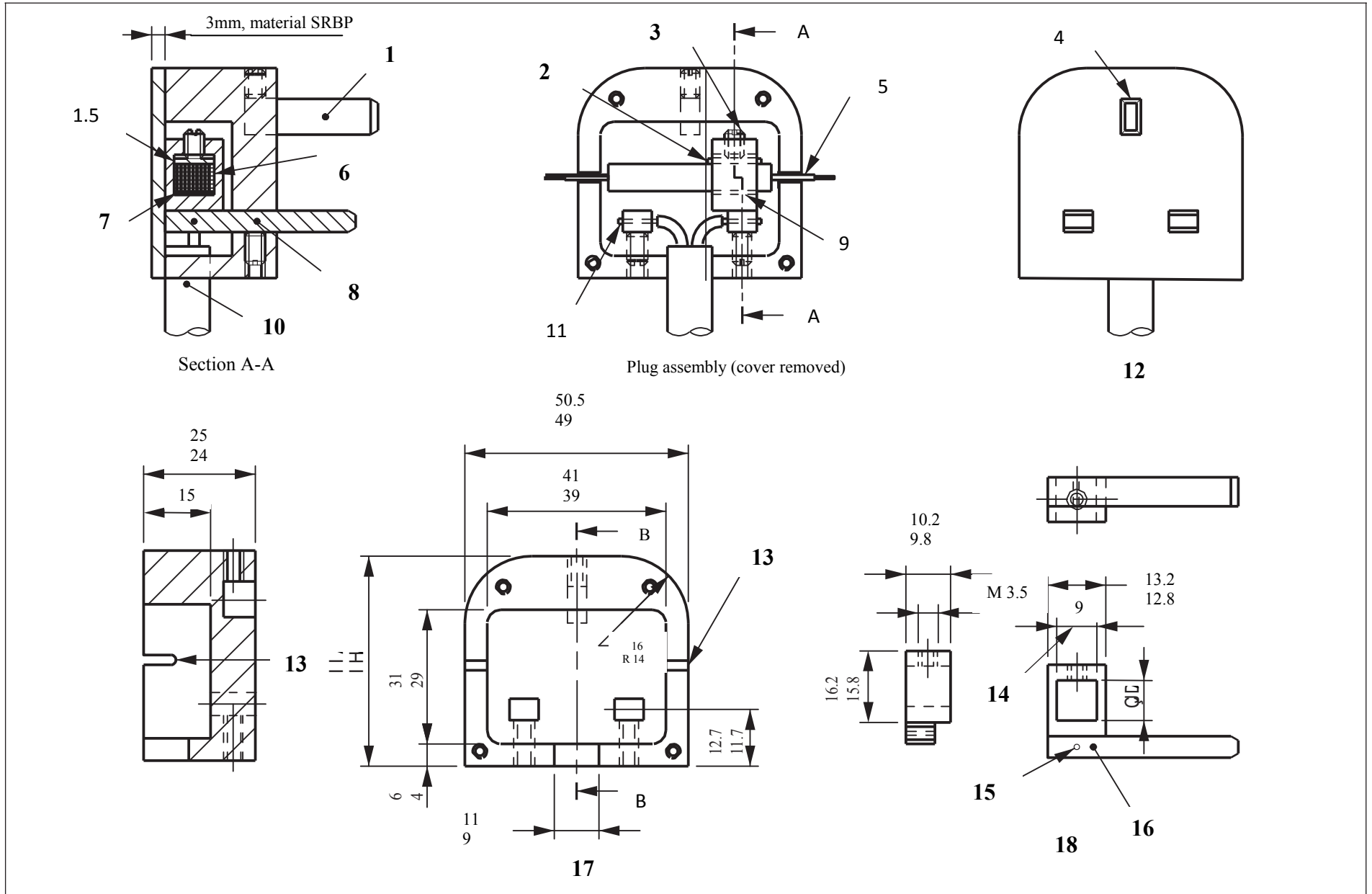


FIGURE 27 – Test plug for temperature rise (see Annex G) (Continued)

Key

- | | |
|--|--|
| 1 Earth pin (not connected) secured via grub screw | 11 Conductors of flexible cable soldered to pins |
| 2 1.5 thick clamp plate (brass) | 12 View on engagement face |
| 3 Tighten to 0.2 Nm | 13 Slot for resistor leads |
| 4 Projection size and disposition of pins to be as
SLS 734 Part 1 , Figure 4 | 14 To suit resistor |
| 5 Resistor leads brought out of side or cover and sealed. | 15 Hole for flexible conductor |
| 6 Wire-wound ceramic coated resistor (e.g. 7 W 56 Ω) | 16 Pin SLS 734 Part 1 , Figure 4 brazed to clamp body |
| 7 Thermal contact compound | 17 Body: material SRBP ^{a)} |
| 8 Pin/clamp assembly secured via grub screw | 18 L - Pin/clamp sub-assembly: material brass, N - Pin only |
| 9 Thermal contact compound | |
| 10 Flexible cable 1.25 mm ² 2-core 1 m length (as in SLS 1504-2-11) | |

NOTE: *Dimensions are in millimetres.*

^{a)} Material SRBPs such as defined in **BS 2572** or **IEC 60893-3-4**.

FIGURE 27 – Test plug for temperature rise (see Annex C) (Concluded)

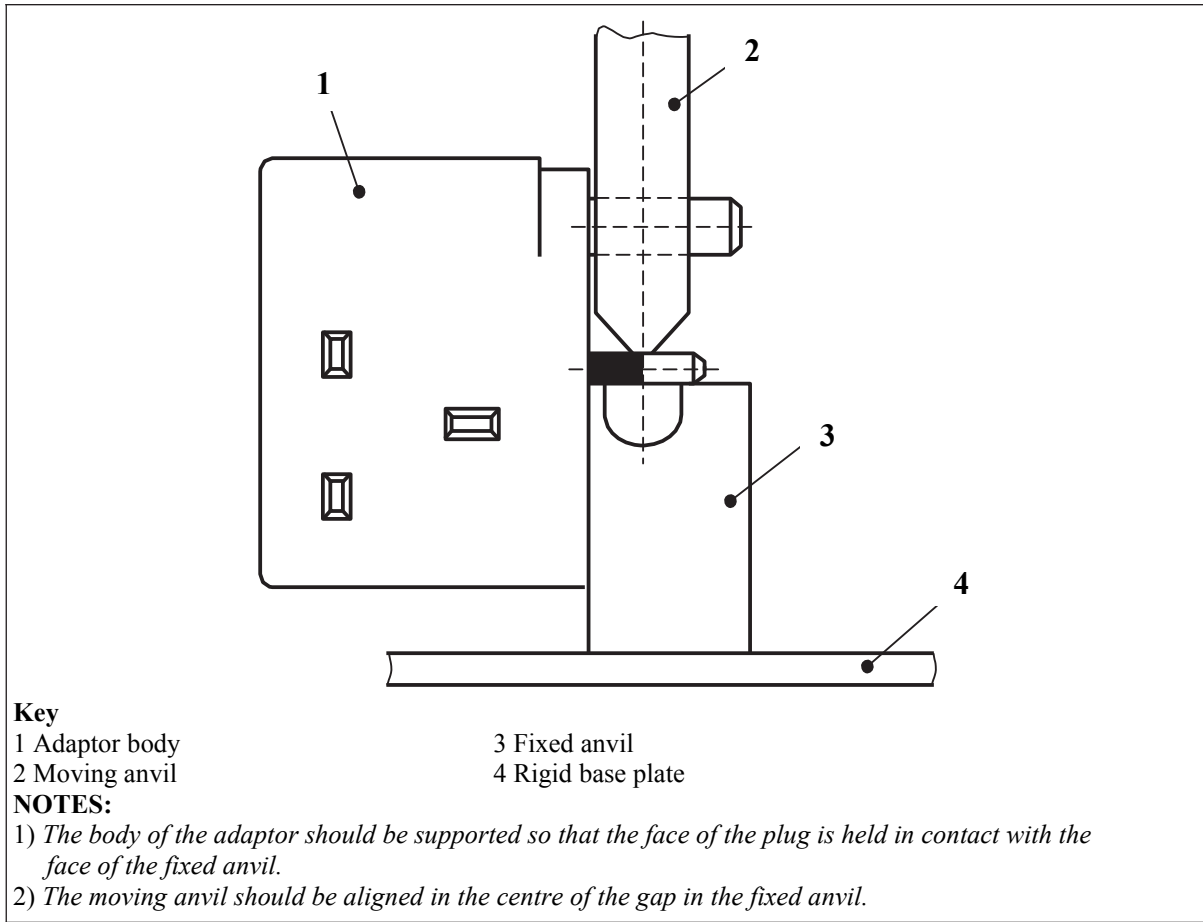


FIGURE 28a) - Apparatus for tests on adaptor pins: An adaptor pin under test (see 12)

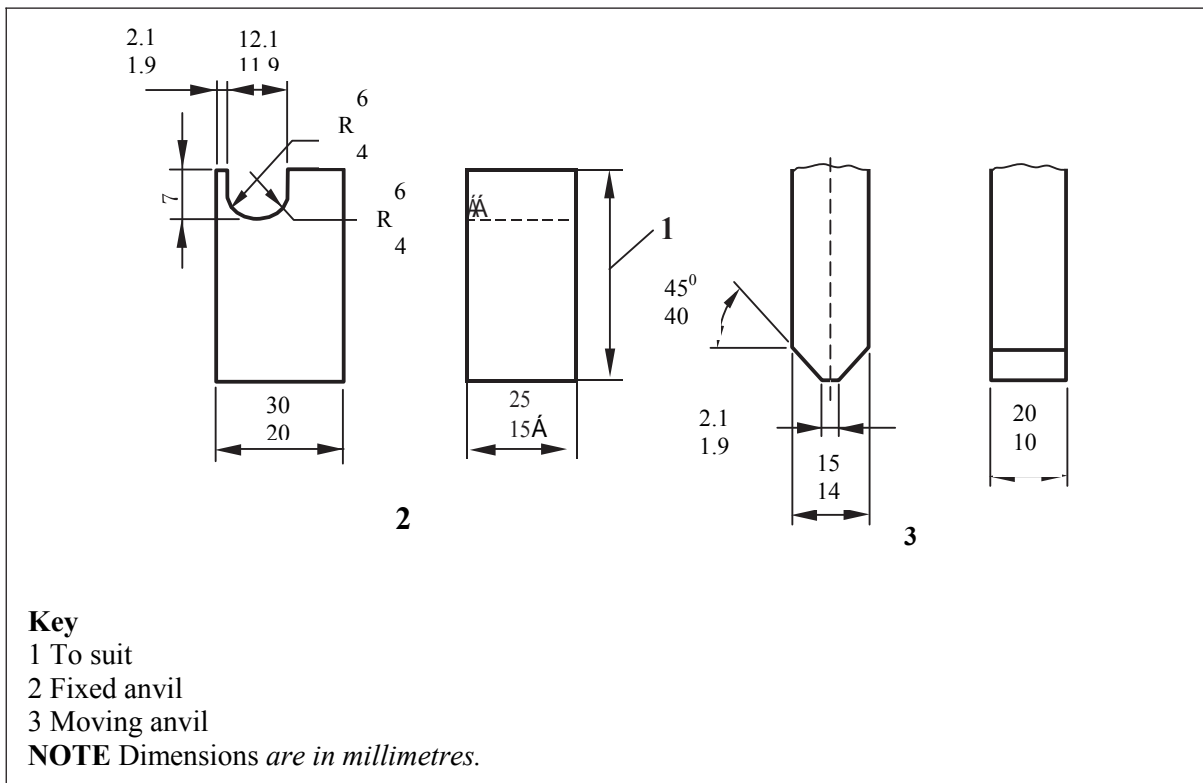


FIGURE 28b) - Apparatus for tests on adaptor plug pins: Details of anvils (see 12)

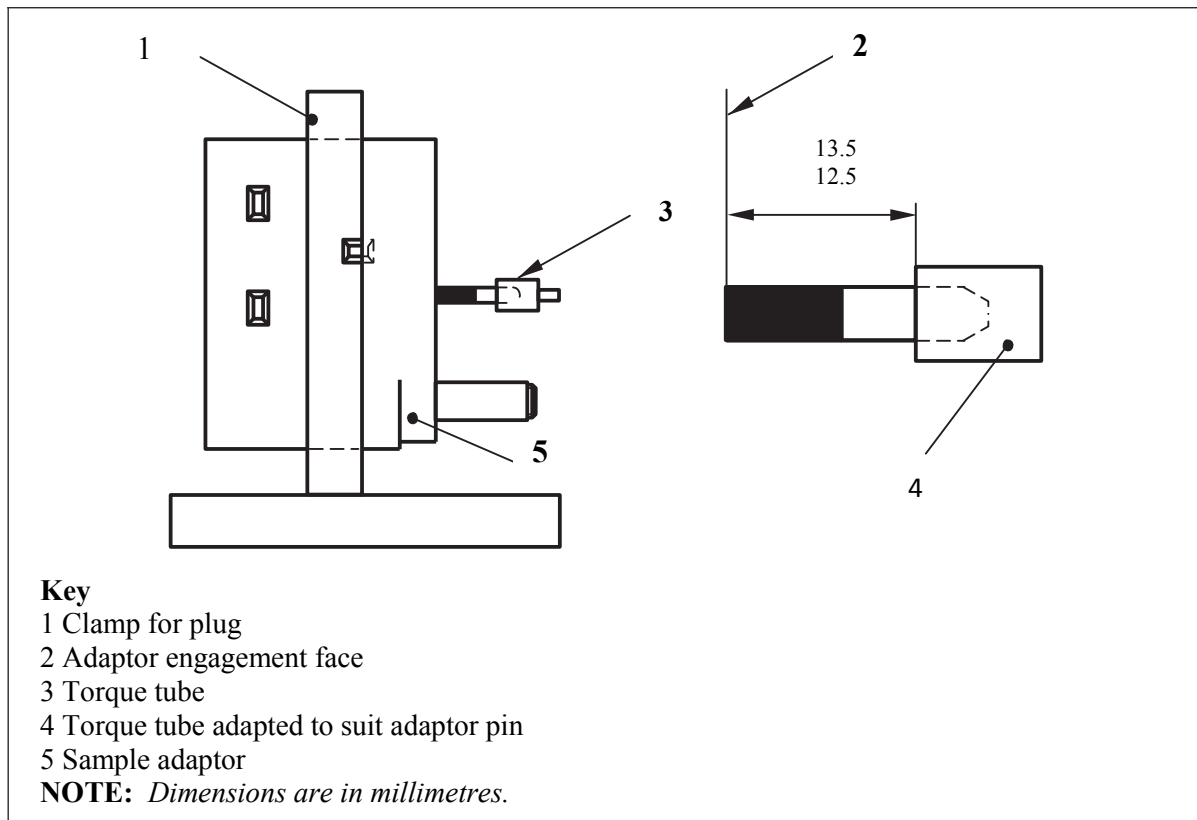


FIGURE 29 – Apparatus for torsion test on pins (see 12)

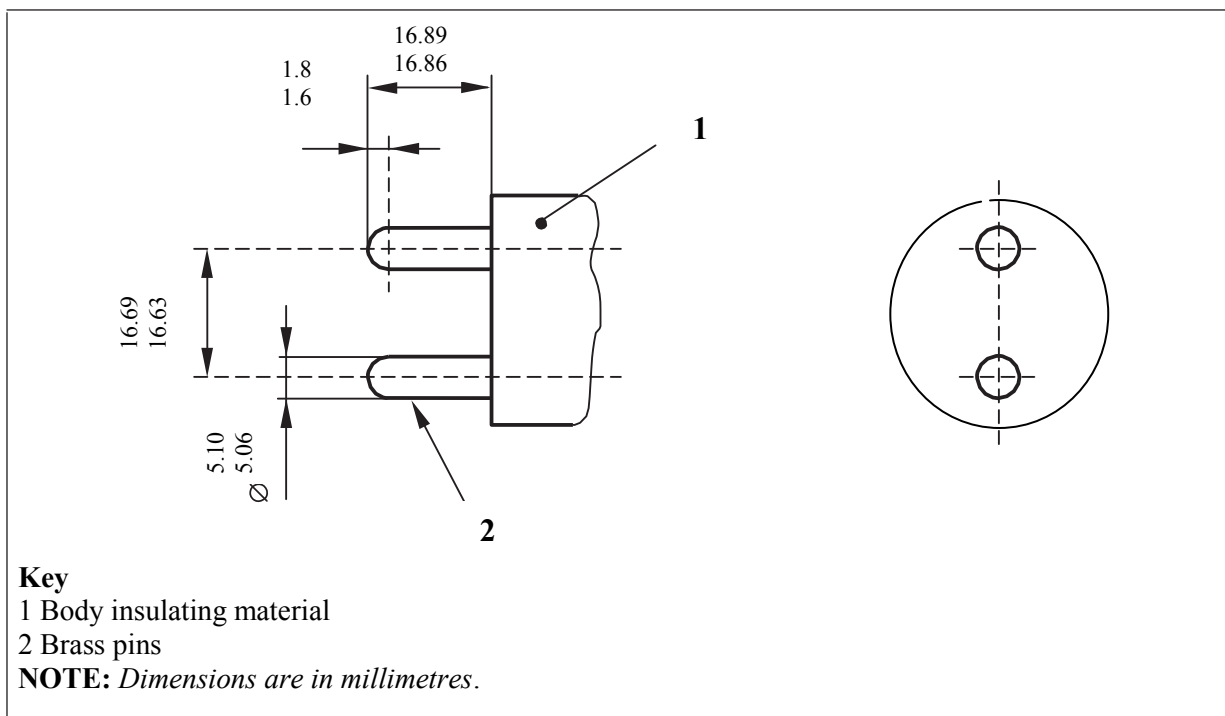


FIGURE 30 – Test plug (see 16)

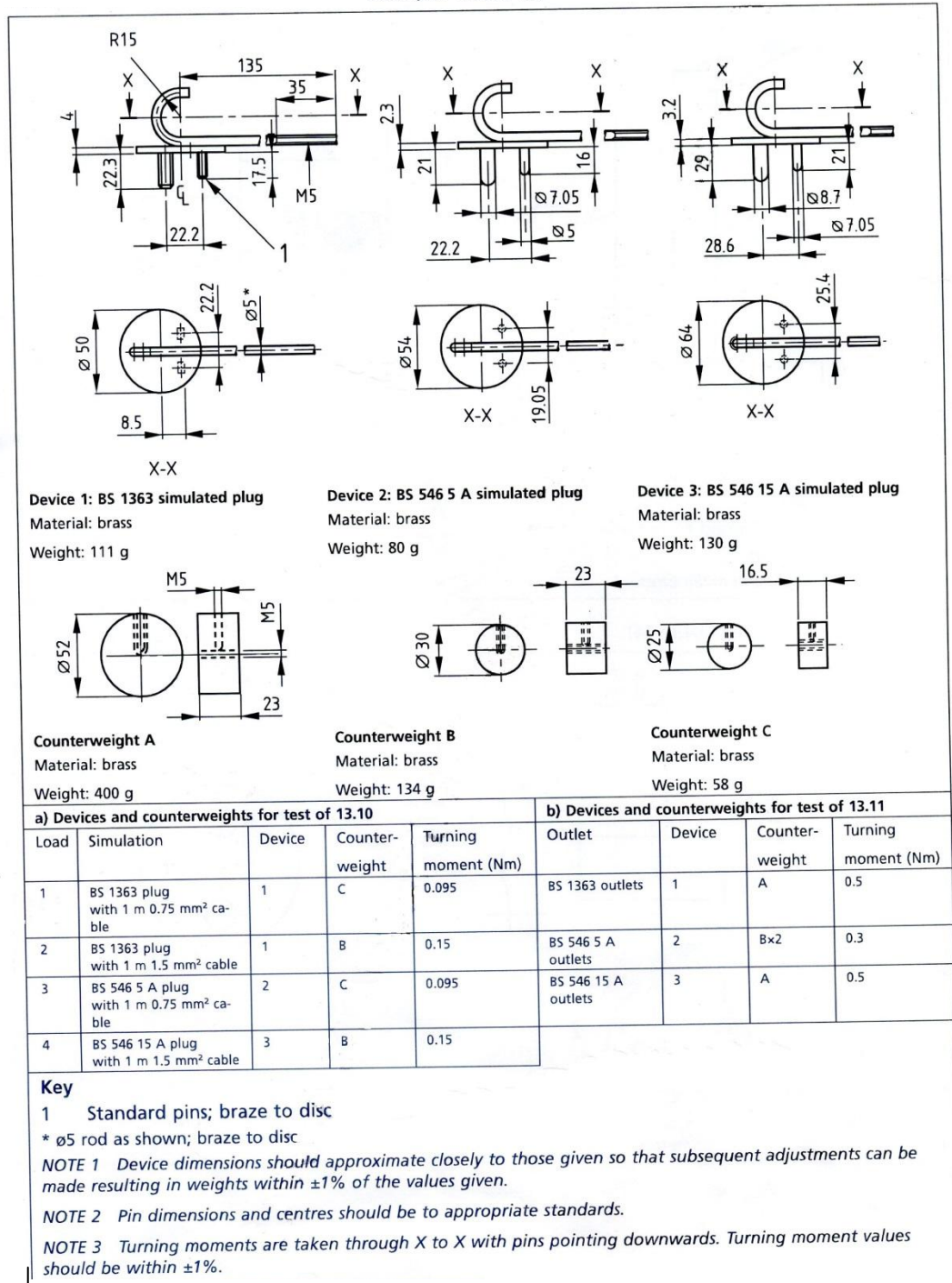


FIGURE 31 – Simulated plug and cable devices (see 13)

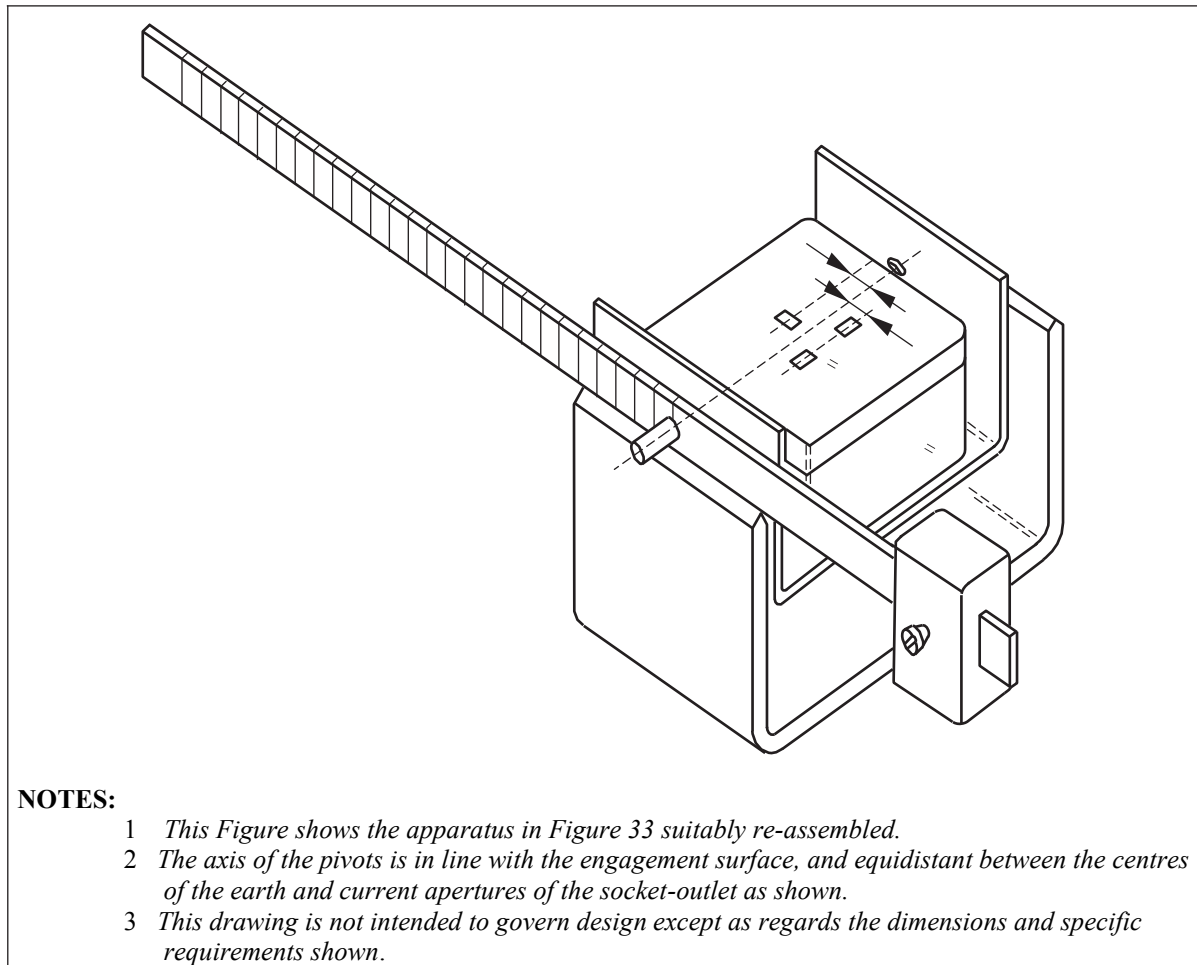


FIGURE 32 – Apparatus for calibration of turning moment of simulated plug (see 13)

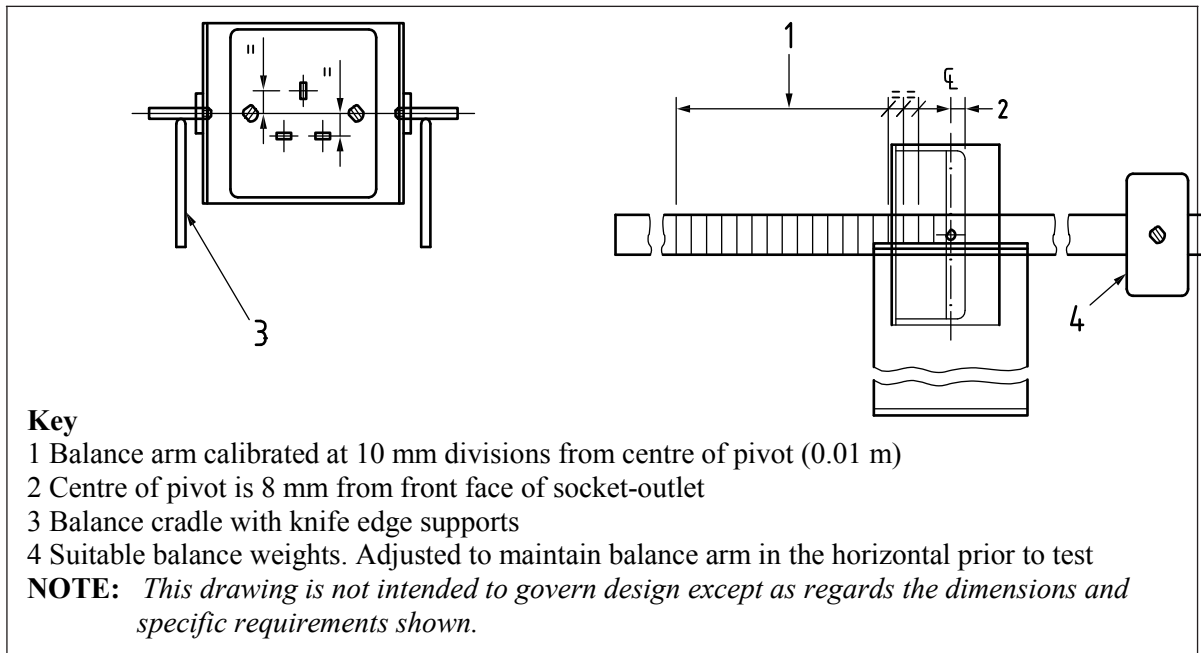


FIGURE 33a - Turning moment apparatus: Front view and side view (see 13)

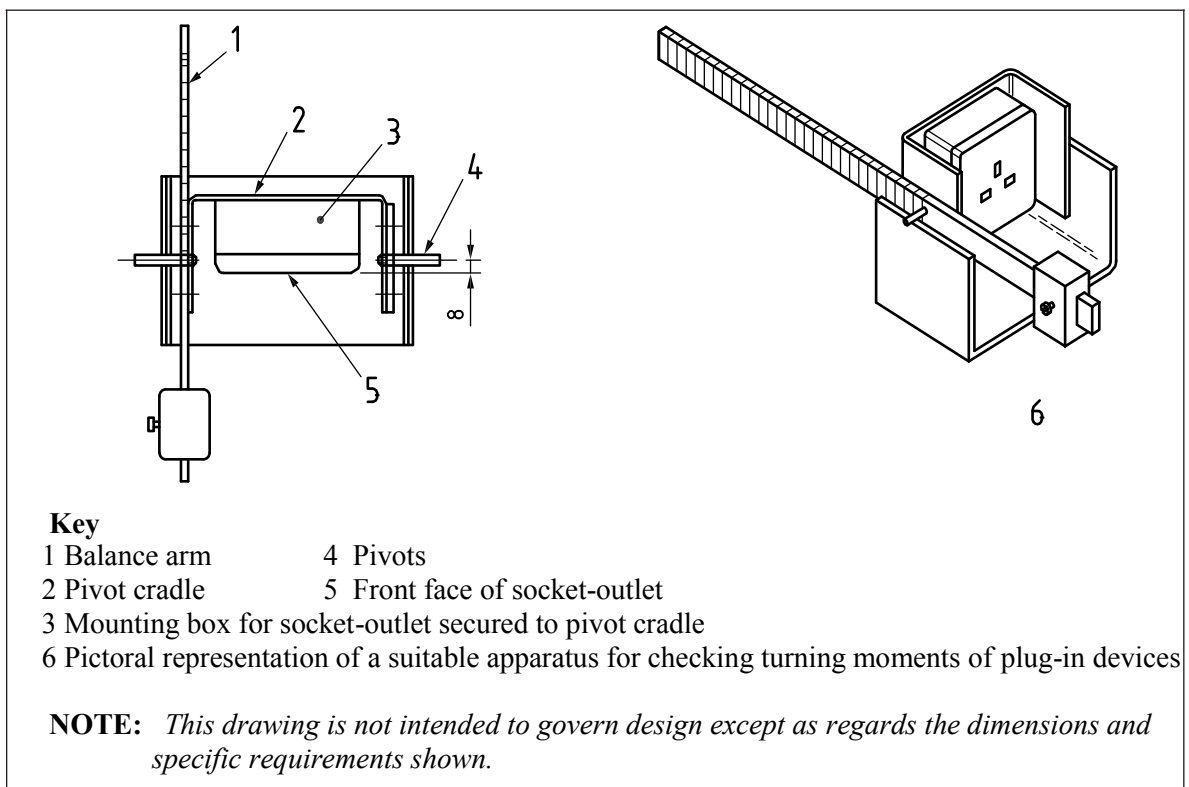


FIGURE 33b - Turning moment apparatus: Top view and pictorial overview (see 13)

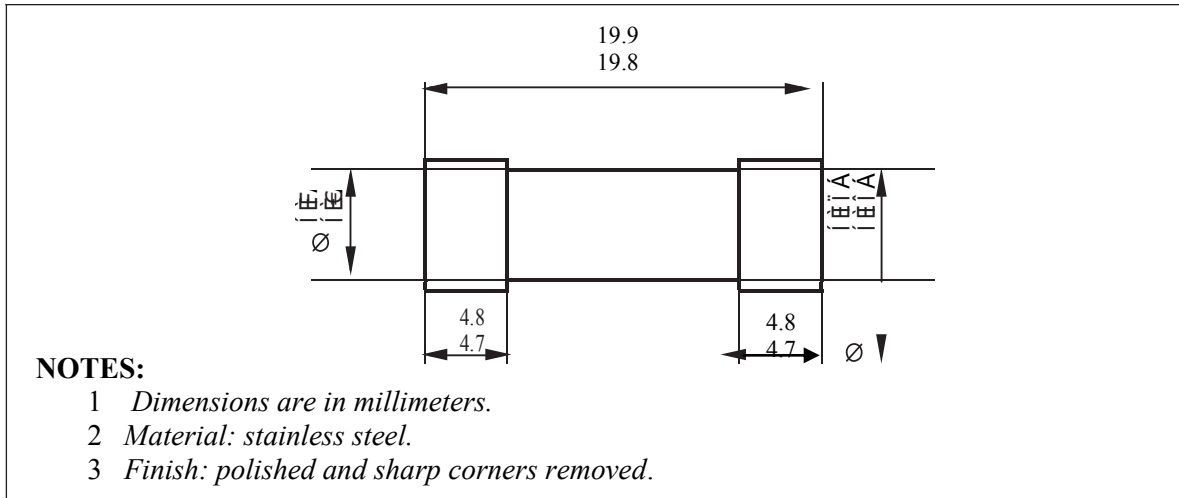


FIGURE 34 – Solid links for test on fuse clips (see 20)

ANNEX A (Normative)

THE CONSTRUCTION AND CALIBRATION OF A CALIBRATED LINK

A.1 CONSTRUCTION

The calibrated link (see Figure 25) shall employ the following components used to produce fuses conforming to SLS 1533.

- Ceramic body (as standard);
- filing (as standard);
- end caps [modified standard cap as shown in Figure 25a].

The resistive element shall be of copper nickel wire having a resistivity val between $44 \mu\Omega\cdot\text{cm}$ and $49 \mu\Omega\cdot\text{cm}$. The overall length shall be $25.4^{+0.8}_{-0.4}$ mm and the diameter such as to allow a small reduction in the cross-sectional area to adjust the watts loss to be required value. The ends are turned down so that the distance between the shoulders so formed shall be $25.4^{+0.8}_{-0.4}$ mm less twice the end cap end wall thickness “ t ” (see Figure 25b).

The resistive element shoulders shall be firmly butted to the inside faces of the end caps and soldered using at in silver solder, grade 96 S, as specified in BS 219. The assembly thus formed (see Figure 25c) shall be checked for watts loss in accordance with A. 2. Metal shall then be filed carefully from the resistive element over as long a length as is possible and the assembly rechecked until the desired watts loss is achieved.

One end cap shall then be unsoldered, a standard ceramic body fitted, the cavity filled and the end cap resoldered in position making sure the shoulder of the element is butted to the inside of the end cap; the ceramic body shall not interfere with this condition [see Figure 25d)]. The watts loss shall be rechecked in accordance with A.2 and adjusted if necessary.

The resulting calibrated link shall be marked “NOT A FUSE” on the ceramic body and shall dimensionally be in accordance with SLS 1533.

A.2 CALIBRATION

The calibration jig shown in Figure 26 is mounted horizontally approximately 25 mm above a wooden board by means of two ceramic pillars. A fine wire thermocouple is attached to the centre of each fuse contact clip, on the outside of the top edge, in such a way that it does not interfere with the contact area. The thermocouples are taken out of the box in slots cut in one end of the jig base, the width of the slots just being sufficient to accept the diameter of the thermocouples. The connection to the jig base shall be by means of PVC insulated single-core copper cables, $0.3 \text{ m} \pm 0.05 \text{ m}$ in length and 2.5 mm^2 cross-section.

The surroundings shall be free from draughts and the ambient air temperature, measured by a suitable thermometer or thermocouple at a horizontal distance of 1m to 2 m from the standard link shall be in the range of $15 \text{ }^\circ\text{C}$ to $25 \text{ }^\circ\text{C}$. The standard link shall be inserted into the clips provided in the calibration jig and the cover replaced. A current of $13\text{A} \pm 0.1 \text{ A}$ is then passed continuously through the calibrated link for $60 \text{ min} \pm 5\text{min}$. At the end of this

time the temperature measured by the thermocouples are noted, the cover of the jig is then removed and the millivolt drop between the end surfaces of the end caps of the calibrated link is measured while it is still carrying the test current.

Alternating current (a.c.) shall be used for the calibration.

The calibration is considered to be correct when the following apply

- a) The product of the measured millivolt drop multiplied by the test current gives result of $1_{-0.050} W$;
- b) The temperature difference between the fuse contact clips does not exceed °C.

**ANNEX B
(Normative)**

MEASUREMENT OF CLEARANCE AND CREEPAGE DISTANCES

The width X specified in Examples 1 to 11 apply to all examples as a function of the pollution degree as given in Table B.1.

TABLE B.1 - Minimum values of width

Pollution degree	Minimum values of width X mm
1	0.25
2	1.0
3	1.5

If the associated clearance is less than 3 mm, the minimum groove width may be reduced to one third of this clearance.

The methods of measuring creepage distances and clearances are indicated in the following Examples 1 to 11. These cases do not differentiate between gaps and grooves or between types of insulation.

The following assumptions are made:

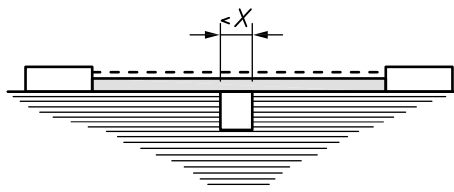
- ~Á any recess is assumed to be bridged with an insulating link having a length equal to the specified width X and being placed in the most unfavourable position (see Example 3);
- ~Á where the distance across a groove is equal to or larger than the specified width X , the creepage distance is measured along the contours of the groove (see Example 2);
- ~Á creepage distances and clearances measured between parts which can assume different positions in relation to each other, are measured when these parts are in their most unfavourable position.

Explanation for examples 1 to 11



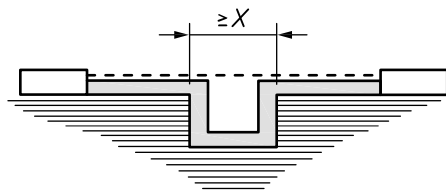
All dimensions are in millimeters.

Example 1



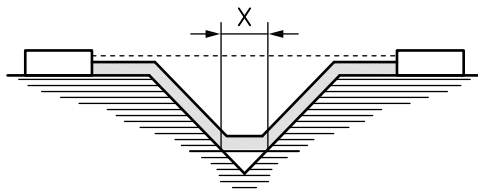
Condition: Path under consideration includes a parallel- or converging sided groove of any depth and with a width less than “X” mm.
Rule: Creepage distance and clearance are measured directly across the groove as shown.

Example 2



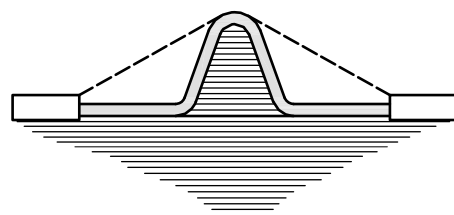
Condition: Path under consideration includes a parallel- sided groove of any depth and with a width equal to or greater than “X” mm.
Rule: Clearance is the “line of sight” distance. Creepage path follows the contour of the groove.

Example 3



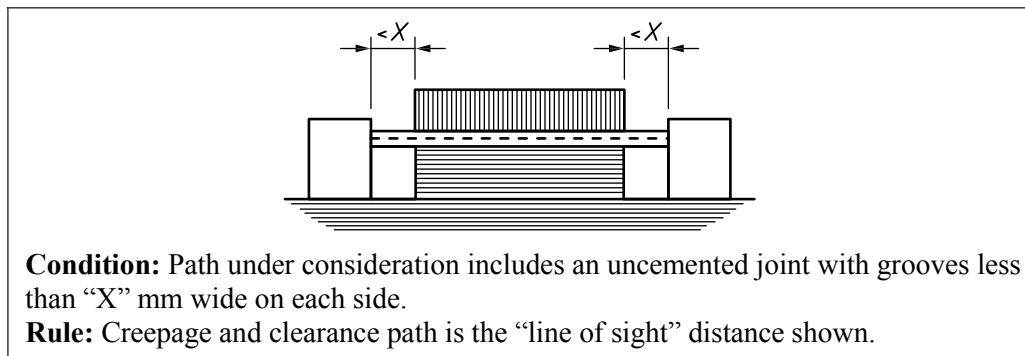
Condition: Path under consideration includes a V-shaped groove with a width greater than “X” mm.
Rule: Clearance is the “line of sight” distance. Creepage path follows the contour of the groove but “short-circuits” the bottom of the groove by an “X” mm link.

Example 4

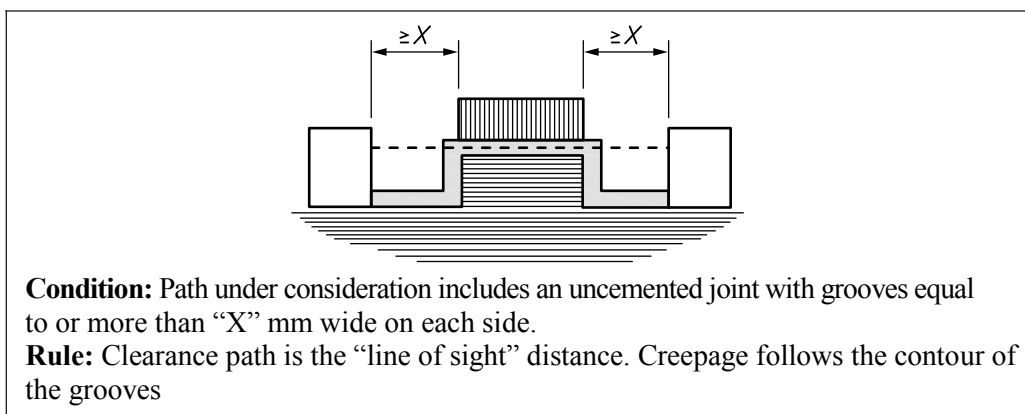


Condition: Path under consideration includes a rib.
Rule: Clearance is the shortest direct air path over the top of the rib. Creepage path follows the contour of the rib.

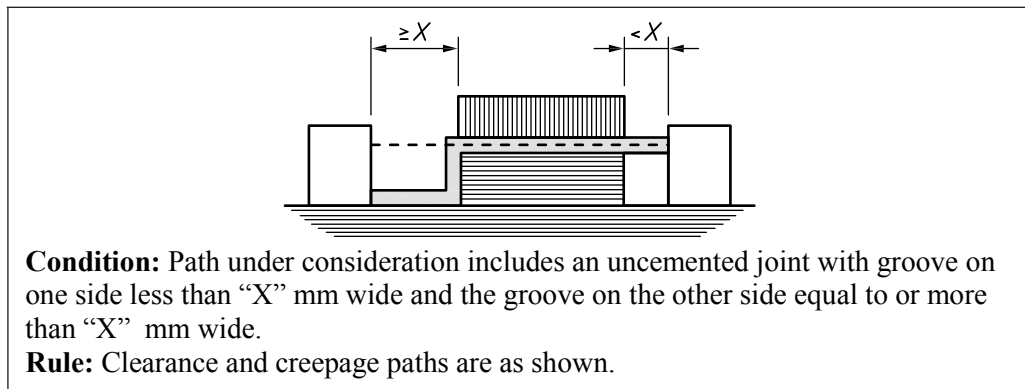
Example 5



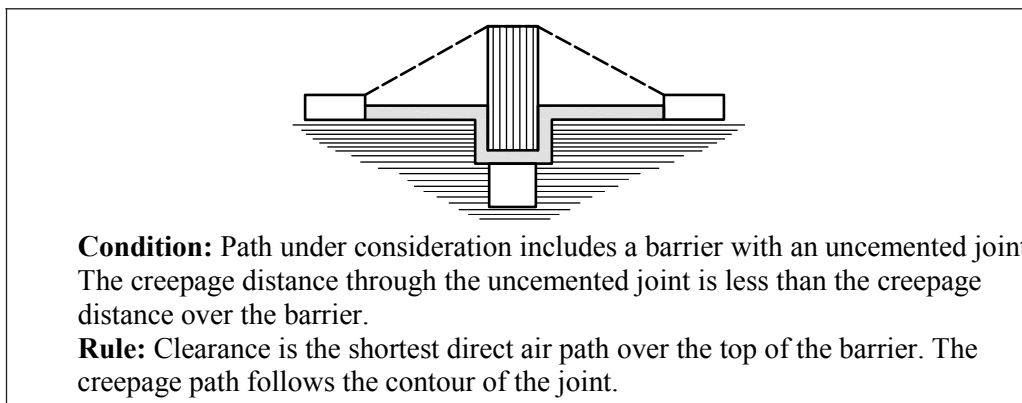
Example 6



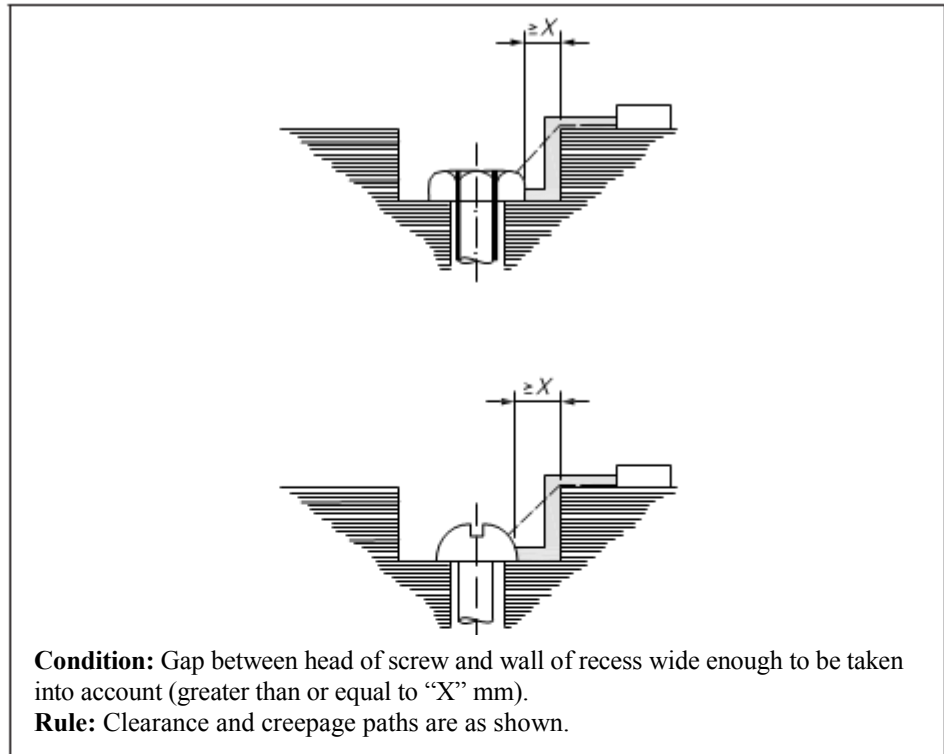
Example 7



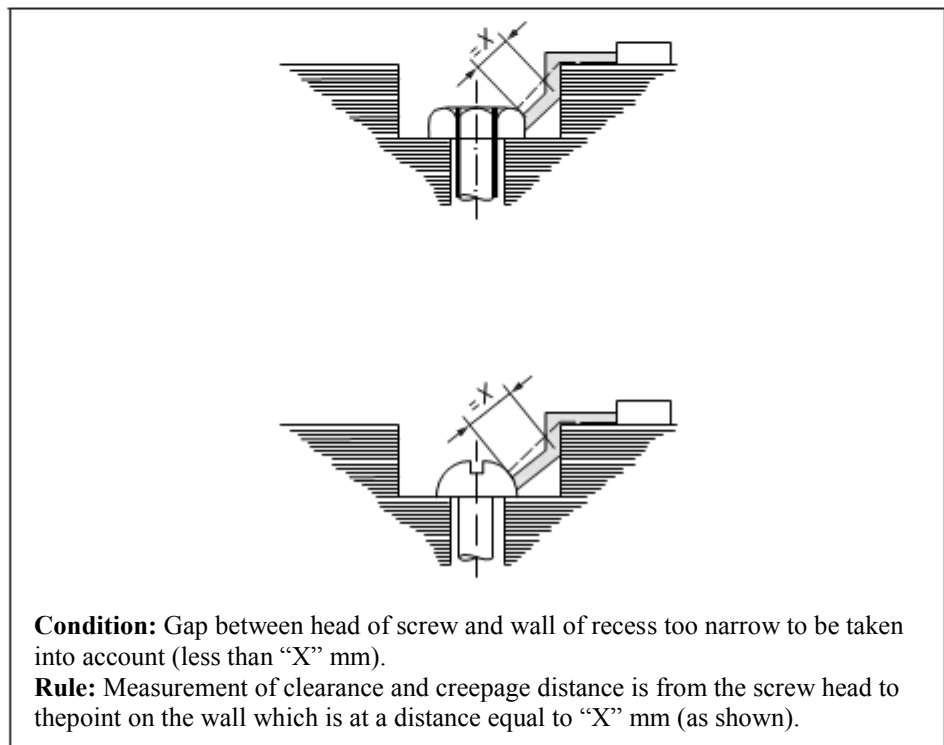
Example 8



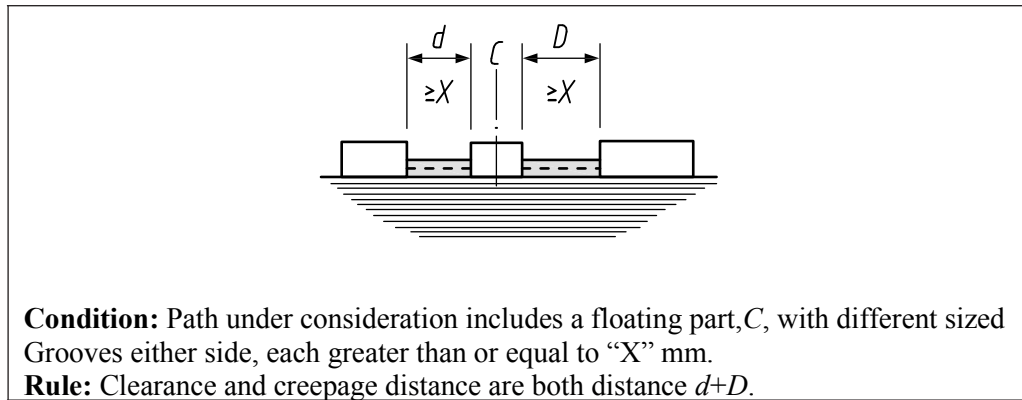
Example 9



Example 10



Example 11



ANNEX C
(Normative)

**DETERMINATION OF THE COMPARATIVE TRACKING INDEX (CTI) AND
PROOF TRACKING INDEX (PTI)**

The CTI or PTI is determined in accordance with **IEC 60112**. For the purpose of this standard the following applies.

- a) In Clause **5** of **IEC 60112**, Test sample:
 - i) Note **3** and the last paragraph also apply to PTI:
 - ii) If the surface 15 mm x15 mm cannot be obtained because of the small dimensions of the PT system then special samples made with the same manufacturing process may be used.
- b) The test solution “A” described in **7.3** of **IEC 60112** shall be used.
- c) In Clause **8** of **IEC 60112**, procedure, either CTI or PTI is determined
 - i) CTI is determined in accordance with Clause **11** of **IEC 60112**
 - ii) The PTI test of Clause **10** of **IEC 60112** is performed on five samples at the voltage referred to in Clause **10.1** of **IEC 60112** based on the appropriate creepage distance, material group, pollution degree conditions and on the rated voltage of this standard declared by the manufacturer.

ANNEX D
(Normative)

**RELATION BETWEEN RATED IMPULSE WITHSTAND VOLTAGE, RATED
VOLTAGE AND OVERVOLTAGE CATEGORY**

**TABLE D.1 – Rated impulse withstand voltage for plugs energized directly from the
low-voltage mains**

Nominal voltage of the supply system based on SLS 1259 ^{a)} V	Voltage line-to-neutral derived from nominal voltages a.c. or d.c. up to and including V	Rated impulse withstand voltage V		
		Overvoltage Category		
		I	II	III
(1)	(2)	(3)	(4)	(5)
230/400	300	1 500	2 500	4 000

NOTES:

- 1) For more information concerning supply systems see **IEC 60664-1**.
- 2) For more information concerning Overvoltage Category see **IEC 60664-1**.
- 3) Adaptors fall into Overvoltage Category **III**. Parts of Adaptors where appropriate over voltage reduction is provided fall in to Overvoltage Category **I**. Energy consuming equipment falls in to Overvoltage Category **II**.

^{a)}The/ mark indicates a four-wire three-phase distribution system. The lower value is the voltage line-to-neutral, while the higher value is the voltage line-to-line.

ANNEX E
(Normative)

POLLUTION DEGREE

The micro-environment determines the effect of pollution on the insulation. The macro-environment, however, shall be taken in to account when considering the micro-environment.

Means may be provided to reduce pollution at the insulation under consideration by effective use of enclosures, encapsulation or hermetic sealing. Such means to reduce pollution may not be effective when the PT-system is subject to condensation or if, in normal operation, it generates pollutants itself.

Small clearances can be bridged completely by solid particles, dust and water and therefore minimum clearances are specified where pollution may be present in the micro-environment.

NOTE: *Pollution will become conductive in the presence of humidity. Pollution caused by contaminated water, soot, metal or carbon dust is inherently conductive.*

Degrees of pollution in the micro-environment

For the purpose of evaluating creepage distances and clearances, the following three degrees of pollution in the micro-environment are established.

Pollution degree 1

No pollution or only dry, non-conductive pollution occurs. The pollution has no influence.

Pollution degree 2

Only non-conductive pollution occurs except that occasionally temporary conductivity caused by condensation is to be expected.

Pollution degree 3

Conductive pollution occurs or dry non-conductive pollution occurs which becomes conductive due to condensation which is to be expected.

ANNEX F
(Normative)

IMPULSE VOLTAGE TEST

The purpose of this test is to verify that clearances will withstand specified transient overvoltage. The impulse withstand voltage test shall be carried out with a voltage having a 1.2/50 μ s waveform as specified in IEC 61180-1 Section 6 and is intended to simulate overvoltage of atmospheric origin. It also covers overvoltage due to switching of low voltage equipment.

Á

The test shall be conducted for a minimum of three impulses of each polarity with an interval of at least 1s between pulses. There shall be no discharges during the test. Glow discharges without a drop in voltage shall be ignored.

Á

For solid insulation and for clearances not checked by measurement, the impulse withstand voltage shall be applied between:

Á

- a) Line and neutral terminals/terminations;
- b) Line and neutral terminals/terminations connected together and:

Á

- i) A sheet of metal foil in contact with the entire accessible external surface;
- ii) The earthing terminal/termination;
- iii) Any metal part of a cable anchorage;

Each switched pole terminal of a switched plug and corresponding plug pin, with the switch contacts open.

Á

NOTES:

ÁÁ

- 1) *The output impedance of the impulse generator should be not higher than 500 Ω .*
- 2) *The expression “discharge” issued to cover the phenomena associated with the failure of insulation under electric stress, which include current flow and a drop in voltage.*

Á

The impulse shall have the following characteristics:

The waveform 1.2/50 μ s for the no-load voltage with amplitudes equal to the values given in Table F.1;

Á

- 3) *If the sample is provided with surge suppression, the impulse voltage wave may be chopped but the sample should be in a condition to operate normally again after the test. If the sample is not provided with surge suppression and it withstands the impulse voltage, the wave form will not be noticeably distorted.*

TABLE F.1 - Test voltages for verifying clearances at sea level

Rated impulse withstand voltage kV	Impulse test voltage at sea level kV
0.33	0.35
0.5	0.55
0.8	0.91
1.5	1.75
2.5	2.95
4.0	4.8
6.0	7.3

NOTES :

1) *When testing clearances, associated solid insulation will be subjected to the test voltage. As the impulse test voltage of Table F.1 is increased with respect to the rated impulse withstand voltage, solid insulation will have to be designed accordingly. These results in an increased impulse withstand capability of the solid insulation.*

2) *The test may be made with the pressure adjusted to the value corresponding to the altitude of 2 000 m (80 kPa) and 20 °C with the test voltage corresponding to the rated impulse withstand voltage. In this case, solid insulation will not be subjected to the same withstand requirements as when testing at sea level.*

3) *Explanations concerning the influencing factors (air pressure, altitude, temperature humidity) with respect to electric strength of clearances are given in IEC 60664-1.*

ANNEX G
(Normative)

TEST PLUG FOR TEMPERATURE RISE TEST

G.1 General

The test plug consists of a body made from insulating material and pins of brass. The Pin dimensions and centres are shown in Figures 5 & 6.

Inside the test plug a ceramic-covered wire-wound resistor is clamped to the line pin making no electrical contact between the pin and the resistor element, through good thermal contact is essential. Thermal contact compound shall be used on the interface between the ceramic resistor body and the metal clamp.

The M 3.5 clamp screw shall be tightened to a torque of $0.2 \text{ Nm} \pm 0.02 \text{ Nm}$. The resistor leads pass through the sides or cover of the test plug.

Approximately 1 000 mm of 3-core flexible cable as given in **SLS 1504-2-11** with normal cross-section 1.25 mm^2 is connected to the plug by soldering the line and neutral cores to their respective plug pins. The earth core of the cable of the cable is not fitted to the earth pin. Details are shown in Figure 27

G.2 CALIBRATION

The test plug is mounted in the dummy front plate (see Figure 19) and the test carried out in accordance with 16.1.2 with $14 \text{ A} \pm 0.2 \text{ A}$ flowing through the flexible cable attached to the plug. At the same time, a separate low voltage d.c supply is connected to resistor and the voltage adjusted until the temperature rise on the plug pin spacer stabilizes at $35 \text{ K} \pm 1 \text{ K}$. The value of the voltage applied to the resistor is noted. The calibration voltage is applied to the resistor when checking the temperature rise of socket-outlets.

ANNEX H (Normative)

REQUIREMENTS FOR INCORPORATED ELECTRONIC COMPONENTS

H.1 General

Incorporated electronic components shall conform to their relevant standard(s)

NOTE: *Conformity with a standard for the relevant component does not necessarily ensure conformity with this standard.*

H.2 Electromagnetic compatibility (EMC) requirements

Adaptors incorporating electronic circuits, apart from inherently benign components, shall conform to the immunity and emission requirements of the relevant product or generic IEC 61000 standard series. In particular:

- Á IEC 61000-6-1 and
- Á IEC 61000-6-3

NOTE: Inherently benign components do not normally generate electromagnetic disturbances. Examples of inherently benign components are LED indicators, diodes, resistors, varistors, capacitors, surge suppressors, inductors. This list is not exhaustive.

No additional EMC immunity or emission tests are required if the following conditions are fulfilled.

- a) the incorporated devices and components conform to the requirements for EMC as required by the relevant product or generic EMC standard;
- b) the internal installation and wiring is carried out in accordance with the devices and component manufacturer's instructions (arrangement with regard to mutual influences, cable, screening, earthing, etc.).

In all other cases the EMC requirements are to be verified by tests, in particular as per IEC 61000-6-1 and IEC 61000-6-3.

H.3 USB Circuits intended for charging portable devices

H.3.1 General

USB circuits incorporated in an adaptors shall conform to the requirements of:

- Á IEC 60950-1; or
- Á IEC 62368-1; or
- Á IEC 61558-2-16 and IEC 61558-2-6 and
- Á IEC 62680-1-1

The USB circuits shall be tested as a component or sub assembly to **IEC 60950-1**, **IEC 62368-1** or **IEC 61558-2-16** and **IEC 61558-2-6** and when incorporated into the adaptor the USB circuit shall meet the requirements of **IEC 60950-1** or **IEC 62368-1** or **IEC 61558-2-16** (used in conjunction with **IEC 61558-2-6**) as applicable. Where a particular requirement is not considered to be applicable, or alternative means of meeting a requirement is used, then this shall not result in a lesser degree of safety with particular regard to reduction of the risks of fire, electric shock or injury for the operator or layman who may come into contact with the adaptor.

The following requirements relating to the appropriate use of the components or subassembly in the adaptor shall be met.

H.3.1.1 Power rating and identification markings

The input voltage rating of the USB circuit shall not be marked on the adaptor and shall not be less than the rated voltage of the adaptor.

Marking of the USB circuit output:

The following marking shall be visible after the adaptor has been installed as in normal use:

- Á Symbol for nature of supply, for d.c only;
- Á rated current, in milliamperes or amperes; and
- Á rated output voltage

H.3.2 Overcurrent and earth fault protection in primary circuits

Overcurrent protection shall be provided on the primary side of the USB circuit.

Where overcurrent protection is not provided within the USB circuit itself, provision shall be made for appropriate overcurrent protection in the supply to the USB circuit within the adaptor. The USB circuit shall not rely on the building or installation protection device for overcurrent protection.

NOTE: *Provision for overcurrent protection provided within the USB circuit can be verified by reference to the original test report.*

H.3.2.1 Number and location of protective devices

A single overcurrent protection device shall be provided and it shall be located in the line circuit, either within the USB circuit or in the supply to the USB circuit within the adaptor.

H.3.2.2 Electrical insulation

Double or reinforced insulation shall be provided between the primary and secondary circuits of the USB circuit. The output of the USB circuit shall be SELV or equivalent.

When installed in the adaptor, double or reinforced insulation shall be provided between the primary circuit and accessible parts of the adaptor.

H.3.2.3 Clearances, creepage distances and distances through insulation

The USB circuit shall be designed and constructed to conform to the requirements of overvoltage Category **III**. USB circuits of overvoltage Category **II** can be used where additional overvoltage protection is provided within the adaptor i.e. a varistor or equivalent.

NOTES:

1) *USB circuits are generally tested as overvoltage Category **II** whereas adaptors are overvoltage Category **III**.*

2) *IEC 60664 gives guidance on the use of appropriate overvoltage reduction.*

H.3.3 Disconnection from the mains supply

The requirement in **IEC 60950-1** for the provision of a disconnect device shall not apply.

Note: *The disconnect device specified in **IEC 60950-1** is provided by the adopter plug pins.*

H.3.4 Mechanical strength

The requirements of **20** shall be applied to the USB circuit when incorporated in the adopter. The mechanical strength requirements of **IEC 60950-1** are not applicable.

H.3.4.1 Reducing the risk of ignition and spread of flame

Method 1: A fire enclosure shall be provided which meets the requirements of **IEC 60950-1** or

Method 2: Assessment and testing of all possible single fault tests shall be applied. In this case a fire enclosure is not required for equipment or that portion of equipment for which testing of all relevant components in both primary circuits and secondary circuits has been carried out. Whichever method is selected, the material requirements of **22** and **23** are also applicable.

H.3.4.2 Performance requirements

USB circuits intended for charging portable devices shall conform to the requirements for dedicated charging ports (DCP) of **IEC 62680-1-1**.

H.3.5 Conformity

Conformity to **H.3.1** to **H.3.4** shall be verified by inspection of compliance evidence or by test.

H.4 Surge protective devices

H.4.1 General

Surge protective devices incorporated in this standard adopters shall conform to the requirements in **H.4.2**.

NOTES:

1) The use of SPDs, variously known as voltage dependant resistors (VDRs), gas discharge tubes, avalanche breakdown diodes and similar devices, might have particular applications and restrictions in their use in many safety standards. Restrictions are applied where the disconnection of earth is possible as a single fault condition (applicable for example, to domestic pluggable equipment).

The slow deterioration of surge protection devices with time might result in an increase in leakage current. This can cause a permanent and continuously increasing temperature stress, which can cause component to burn or burst, and thus SPDs/ VDRs are regarded as potential safety hazards.

2) This Annex does not cover comprehensive type testing which is specified in the IEC 61643 series.

H.4.2 Requirements

The following types of SPD of the appropriate category shall be considered acceptable:

- Metal oxide varistors conforming to **IEC 61643-331**;
- Gas discharge tubes conforming to **IEC 61643-321**;
- Avalanche breakdown diodes conforming to **IEC 61643-311**.

VDRs conforming to **IEC 61051-2** and having the following characteristics shall be considered acceptable:

a) Preferred climatic categories:

Lower category temperature – 10 °C

Upper category temperature +85 °C

Duration of damp heat, steady state test: 21 days

b) Maximum continuous voltage:

The maximum continuous a.c voltage shall be not less than 315 V.

c) Pulse current (**IEC 61051-2**, Table 1, Group 1)

Combination pulses of 6 kV/ 3 kA of alternating polarity are used, having a pulse shape of 1.2/50 µs for voltage and 8/20 µs for current.

In addition to the performance requirements of **IEC 61051-2**, Table 1 Group 1, the clamping voltage after the test shall not have changed by more than 10 per cent, when measured with the manufacturer's specified current.

H.4.3 Conformity

Conformity to **H.4.2** shall be checked by inspection of component conformity evidence.

H.4.4 Incorporation of VDRs in adaptors

A circuit interrupting devices having adequate breaking capacity shall be connected in series with the VDR to provide protection against:

- a) temporary over voltages above the maximum continuous voltage;
- b) thermal overload due to leakage current within the VDR;
- c) burning and bursting of the VDR incorporation are permitted.

The following methods of VDR incorporation are permitted

- 1) Between L and N

A VDR is permitted between line and neutral provided that it is protected by the **SLS 1533** in the adoptor.

Where not protected by a **SLS 1533** fuse, a circuit interrupting device having adequate breaking capacity shall be incorporated within the product in series with the VDR.

- 2) Between L and E

A VDR is permitted between line and protective earth provided it is protected by the **SLS 1533** fuse in the adopter and is connected in series with a spark gap/gas tube meeting the requirements for basic insulation, or

Where not protected by a **SLS 1533** fuse a VDR is permitted between line and protective earth provided it is located in series with a circuit interrupting device having adequate breaking capacity, and is connected in series with a spark gap/gas tube meeting the requirements for basic insulation.

H.4.5 Conformity

Conformity to **H.4.4** shall be checked by inspection.

H.5 Electronic switches

H.5.1 General

Electronic switches incorporated in adaptors shall conform to **IEC 60669-2-1**.

H.5.2 Conformity

Conformity to **H.5.1** shall be checked by inspection of conformity evidence or by test.

Amendment No. 1 Approved on 2019-05-08 to SLS 734: Part 3: 2017

SRI LANKA STANDARD SPECIFICATION FOR 13 A PLUGS, SOCKET-OUTLETS, ADAPTORS AND CONNECTION UNITS PART 3: SPECIFICATION FOR ADAPTORS

- 1) Replace the existing Table 1 with the following Table including new Note 3)

TABLE 1- Schedule of tests

Sequence	Sample	Tests	Clause number
(1)	(2)	(3)	(4)
1	3	Inspection, measurement, gauging and manipulation	5, 6, 7, 9.1, 9.2, 9.3, 9.5, 9.6, 10.1, 11.1, 12.1, 12.2, 12.3, 12.4, 12.5, 12.11 (12.11.1, 12.11.2, 12.11.3 and 12.11.6 only), 12.15, 12.16, 12.17, 12.18, 13.1, 13.2, 13.3, 13.4, 13.5, 13.8, 13.9, 13.10, 13.13** 19.2, 19.3, 19.4, 19.6, 8 (except Annex C) and 21
2	3	General	5, 9.4, 19.1, 12.14, 12.19.2, 12.19.3, 12.19.2
3	3		5, 20.1.2, 20.1.3, 17, 13.12.1, 20.1.4, 16
4	3		5, 14.2, 12.10, 19.5, 12.19.4
5	3		5, 14.1, 20.1.5, 12.9, 10.2, 12.12, 12.6, 12.7, 12.8, 12.13
6	3		5, 14.1, 15, 13.7, 18, 13.11
7	3*		5, 12.11.4
8a)	9	Additional tests for adaptors with non-solid pins and/or an ISOD	5, 12.11.5
8b)	3	Additional tests for adaptors fitted with an ISOD	5, 12.11.4.3
9	3	Materials	5, 22
10	3		5, 23.2, 8.2 (Annex C only)
11	3		5, 24
12 ^A)	3	Positive break (switched adaptors)	5, 13.12.2
13	3	Overloads	5, 14.1, 25

NOTES:

- 1) *denotes that an additional three samples will be required for adaptors with non-solid pins.
- 2) The order of tests given in sequence 1 is preferred but not obligatory except where required within the text of the appropriate clause.
- 3)**denotes that an additional three samples may be required for plugs incorporating electronic components

AMD 520

A) An additional new set of three samples prepared with the contacts closed is supplied by the manufacturer for this test.

2) Clause 13.13

Add new clause as 13.13, immediately after clause 13.12.3 as follows :

13.13 Electronic components incorporated in adaptors shall conform to Annex **H**

13.13.1 Conformity shall be checked by inspection of component conformity evidence and the tests of Annex **H**.

3) Clause H.4.2 of Annex H

The first paragraph of clause **H.4.2** of Annex **H** shall be corrected as follows:

H.4.2 Requirements

The following types of SPD of the appropriate category shall be considered acceptable:

- metal oxide varistors conforming to **IEC 61643-331**;
- gas discharge tubes conforming to **IEC 61643-311**;
- avalanche breakdown diodes conforming to **IEC 61643-321**.

.....

SLS CERTIFICATION MARK

The Sri Lanka Standards Institution is the owner of the registered certification mark shown below. Beneath the mark, the number of the Sri Lanka Standard relevant to the product is indicated. This mark may be used only by those who have obtained permits under the SLS certification marks scheme. The presence of this mark on or in relation to a product conveys the assurance that they have been produced to comply with the requirements of the relevant Sri Lanka Standard under a well designed system of quality control inspection and testing operated by the manufacturer and supervised by the SLSI which includes surveillance inspection of the factory, testing of both factory and market samples.

Further particulars of the terms and conditions of the permit may be obtained from the Sri Lanka Standards Institution, 17, Victoria Place, Elvitigala Mawatha, Colombo 08.



SRI LANKA STANDARDS INSTITUTION

The Sri Lanka Standards Institution (SLSI) is the National Standards Organization of Sri Lanka established under the Sri Lanka Standards Institution Act No. 6 of 1984 which repealed and replaced the Bureau of Ceylon Standards Act No. 38 of 1964. The Institution functions under the Ministry of Science, Technology and Research.

The Principal objects of the Institution as set out in the Act are to prepare standards and promote their adoption, to provide facilities for examination and testing of products, to operate a Certification Marks Scheme, to certify the quality of products meant for local consumption or exports and to promote Standardization and quality control by educational, consultancy and research and research activity.

The Institution is financed by Government grants, and by the income from the sale of its publications and other services offered for Industry and Business Sector. Financial and Administrative control is vested in a Council appointed in accordance with the provisions of the Act.

The development and formulation of National Standards is carried out by Technical Experts and representatives of other interest groups, assisted by the permanent officers of the Institution. These Technical Committees are appointed under the purview of the Sectoral Committees which in return are appointed by the Council. The Sectoral Committees give the final Technical approval for the Draft National Standards prior to the approval by the Council of the SLSI.

All members of the Technical and Sectoral Committees render their services in an honorary capacity. In this process the Institution Endeavours to ensure adequate representation of all view points.

In the International field the Institution represents Sri Lanka in the International Organization for Standardization (ISO), and participates in such fields of Standardization as are of special interest to Sri Lanka.