

SRI LANKA STANDARD 734 PART 1 : 2017
UDC 621.316

**SPECIFICATION FOR
13 A PLUGS, SOCKET-OUTLETS,
ADAPTORS AND CONNECTION UNITS
PART 1 : SPECIFICATION FOR REWIRABLE AND
NON-REWIRABLE 13A FUSED PLUGS
(SECOND REVISION)**

SRI LANKA STANDARDS INSTITUTION

Sri Lanka Standard
SPECIFICATION FOR 13 A PLUGS, SOCKET-OUTLETS, ADAPTORS AND
CONNECTION UNITS
PART 1 : SPECIFICATION FOR REWIRABLE AND NON-REWIRABLE 13A FUSED
PLUGS
(SECOND REVISION)

SLS 734 Part 1 : 2017
(AMD 518 Attached)

Gr. 21

Copyright Reserved
SRI LANKA STANDARDS INSTITUTION
17, Victoria Place
Elvitigala Mawatha
Colombo 8
Sri Lanka

Sri Lanka Standards are subject to periodical revision in order to accommodate the progress made by industry. Suggestions for improvement will be recorded and brought to the notice of the Committees to which the revisions are entrusted.

This standard does not purport to include all the necessary provisions of a contract.

© **SLSI 2016**

All right reserved. Unless otherwise specified, no part of this publication may be reproduced or utilized in any form or by any means, electronic or mechanical, including photocopying and microfilm, without permission in writing from the SLSI.

CONTENTS

CLAUSE	PAGE
Foreword.....	3
1 Scope	3
2 References.....	4
3 Terms and definitions.....	6
4 Conditions of use.....	9
5 General conditions for type testing.....	10
6 Classification.....	12
7 Marking and labelling.....	12
8 Clearances, creepage distances and solid insulation	15
9 Accessibility of live parts	18
10 Provision for earthing.....	19
11 Terminals and terminations	21
12 Construction of plugs	23
13 Resistance to ageing and to humidity	33
14 Insulation resistance and electric strength	34
15 Temperature rise.....	35
16 Breaking capacity of switched incorporated in fused plugs.....	37
17 Normal operation of switches.....	37
18 Connection of flexible cable and cable anchorage.....	37
19 Mechanical strength.....	40
20 Screws, current- carrying parts and connections.....	41
21 Resistance to heat	43
22 Resistance to abnormal heat and fire	43
23 Resistance to excessive residual stresses and to rusting	45
24 Electrical and thermal stress of clamp type (screwless) terminals	45
25 Overload tests	46
26 Cyclic loading test.....	47

List of Tables

Table 1	Schedule of tests.....	11
Table 2	Rated current and maximum fuse rating in normal use, and load for flexing and cable grip tests related to size of flexible cable	14
Table 3	Minimum clearances for basic insulation.....	16
Table 4	Minimum creepage distances (mm) for basic insulation	17
Table 5	Withstand voltages for insulation types.....	18
Table 6	Torque values for screws and nuts.....	20
Table 7	Actuator test force.....	32
Table 8	Permitted temperature rises	36
Table 9	Connection of flexible cables.....	40
Table 10	Application of glow-wire test	44
Table F.1	Test voltages for verifying clearances at sea level	83
Table H.1	List of Clauses.....	87

List of Figures

FIGURE 1 - Test pin (see 9).....	48
FIGURE 2 - Apparatus for mechanical strength test on resilient covers (see 9).....	49
FIGURE 3 - Hardwood block for Figure 2	50
FIGURE 4 - Dimensions and disposition of pins (see 12) (Continued)	51
FIGURE 4 - Dimensions and disposition of pins (see 12) (Concluded)	52
FIGURE 5 – Concave shrinkage allowances for ISODs.....	53
FIGURE 6 - Gauge for plug pins (see 12, 19, and 21) (Continued)	54
FIGURE 6 - Gauge for plug pins (see 12, 19, and 21) (Concluded)	55
FIGURE 7 - Apparatus for testing plug cover fixing screws (see 12).....	55
FIGURE 8 - Mounting plate (see 12).....	56
FIGURE 9 – Plug pin deflection test apparatus for resilient adaptors (see 12) (Continued)	57
FIGURE 9 – Plug pin deflection test apparatus for resilient adaptors (see 12) (Concluded)	58
FIGURE 10 - Apparatus for abrasion test insulating sleeves of plug pins (see 12).....	59
FIGURE 11 - Apparatus for Pressure test at high temperature (see 12).....	60
FIGURE 12 – Go gauge for socket- outlet (see 12).....	61
FIGURE 13 - Test apparatus for temperature rise test (see 15).....	62
FIGURE 14 – Dummy front plate for temperature rise test (see 15) (Continued).....	63
FIGURE 14 – Dummy front plate for temperature rise test (see 15) (Concluded)	64
FIGURE 15 –Apparatus for flexing test (see 18).....	64
FIGURE 16 – Solid link for test on fuse clips (see 19).....	65
FIGURE 17 – Tumbling barrel (see 19)	65
FIGURE 18 - Apparatus for pressure test (see 21) (Continued)	66
FIGURE 18 - Apparatus for pressure test (see 21) (Concluded).....	67
FIGURE 20- Calibration jig for calibrated link (see A.2) (Continued)	69
FIGURE 20- Calibration jig for calibrated link (see A.2) (Concluded).....	70
FIGURE 21 - Apparatus for tests on plug pins pins : A plug pin under test (see 12)	71
FIGURE 22 - Apparatus for tests on plug pins: Details of anvils (see 12).....	71
FIGURE 23 – Apparatus for torsion test on pins (see 12)	72
FIGURE I.1 - Normal plug profile	88
FIGURE I.2- Compact plug profile.....	89

List of Annexes

Annex A The construction and calibration of a calibrated link	73
Annex B Measurement of clearance and creepage distances.....	75
Annex C Determination of the comparative tracking index (CTI) and proof tracking index (PTI)	79
Annex D Relation between rated impulse withstand voltage, rated voltage and overvoltage	80
Annex E Pollution degree	81
Annex F Impulse voltage test	82
Annex G Requirements for incorporated electronic components.....	84
Annex H Recommendations for products that incorporate SLS 734 plug pins.....	87
Annex I Dimensions for plug profiles.....	88

Sri Lanka Standard
SPECIFICATION FOR 13 A PLUGS, SOCKET-OUTLETS, ADAPTORS AND
CONNECTION UNITS
PART 1 : SPECIFICATION FOR REWIRABLE AND NON-REWIRABLE 13A
FUSED PLUGS
(SECOND REVISION)

FOREWORD

This Standard was approved by the Sectoral committee on Electrical appliances and accessories and was authorized for adoption and publication as a Sri Lankan standard by the council of the Sri Lanka standards institution on 2017-02-24.

This standard is presented in five parts as given below and Part 1 and Part 2 are second revision of **SLS 734: 1996** and other parts are newly included in this standard:

Part 1: Specification for rewirable and non-rewirable 13A fused plugs

Part 2: Specification for 13A switched and unswitched socket outlets

Part 3: Specification for adaptors

Part 4: Specification for 13A fused connection units, switched and unswitched

Part 5: Specification for fused conversion plugs

This is Part 1 of the **SLS 734** and it specifies requirements for 13 A fused plugs having insulating sleeves on line and neutral pins, for household, commercial and light industrial purposes, with particular reference to safety in normal use.

All values given in this specification are in SI unit.

For the purpose of deciding whether a particular requirement of this standard is complied with the final value observed or calculated, expressing the results of a test or an analysis shall be rounded off in accordance with **SLS 102**. The number of figures to be retained in the rounded off values shall be the same as that of the specified value in this standard.

In the preparation of this standard, the assistance derived from the **BS 1363** for 13 A Plugs, Socket outlets, Adaptors and Connection units, Part 1: 2016 Specification for rewirable and non-rewirable 13 A fused plugs is gratefully acknowledged.

1 SCOPE

This part of **SLS 734** specifies requirements for 13 A fused plugs having insulating sleeves on line and neutral pins, for household, commercial and light industrial purposes, with particular reference to safety in normal use. The plugs are suitable for the connection of portable appliances, sound-vision equipment, luminaries, etc. in a.c. circuits only, operating at voltages not exceeding 250 V r.m.s at 50 Hz. Additional requirements are included for plugs suitable for electric vehicle charging.

Requirements are specified for plugs incorporating a fuse link conforming to **SLS 1533**. The plugs may be rewirable or non rewirable complete with flexible cable. Two categories of plugs are specified covering normal and rough use. Rewirable plugs are intended for use with flexible cables conforming to the relevant parts of **SLS 1504**, having conductor cross-sectional areas from 0.5 mm² to 1.5 mm² inclusive (see **18.1**).

Non-rewirable plugs are intended for use with flexible cables having conductor cross-sectional areas not exceeding 1.5 mm² (see **18.4**).

This standard also applies to non-rewirable 13 A plugs which have the earth pin replaced with a similarly dimensioned protrusion made of insulating material designated as an insulated shutter opening device (ISOD) designed to operate the shutter mechanism of socket –outlet conforming to **SLS 734 Part 2**.

A plug is mechanical by nature of construction. The product is therefore immune from electromagnetic interference.

Plug incorporating switches and indicator lamps are included within the scope of this part of **SLS 734**.

Plug incorporating electronic components detailed in Annex **G** are included within the scope of this part of **SLS 734 Part 1**.

Recommendations for plug in equipment incorporating **SLS 734 Part 1** plug pins are given in Annex **H**.

2 REFERENCES

- IEC 60112 Method for the determination of the proof and the comparative tracking indices of solid insulating materials
- IEC 60417-DB Graphical symbols for use on equipment
- IEC 60664-1 Insulation coordination for equipment within low voltage Systems
Part 1: Principles, requirements and tests
Part 3: Use of coating, potting or moulding for protection against pollution
Part 5: Comprehensive method for determining clearances and creepage distances equal to or less than 2 mm
- IEC 60669 Switches for household and similar fixed electrical installations
Part 2-1: Particular requirements – Electronic switches
- IEC 60695 Fire hazard testing
Part 2-11: Glowing hot – wire based test methods-glow-wire flammability test method for end-products (*GWEPT*)
Part 10- 2- Abnormal heat – ball pressure test
- IEC 61000 Electromagnetic compatibility (EMC)
Part 6-1: Generic standards – Immunity for residential, commercial and light industrial environments

Part 6-3: Emission standard for residential, commercial and light industrial environments

IEC 61032	Protection of persons and equipment by enclosures-probes for verification
IEC 61051	Harmonized system of quality assessment for electric components Part 2 Varistors for use in electronic equipment – Section specification for surge suppression varistors
IEC 61140	Protection against electric shock – Common aspects for installation and equipment
IEC 61180	Guide to high-voltage test techniques for low-voltage equipment Part 1: Definitions, test and procedure requirements
IEC 61643	Components for low voltage surge protective devices Part 311: Performance requirements and test circuits for gas discharge tubes (GDT) Part 321: Specifications for avalanche breakdown diode (ABD) Part 331: Specification for metal oxide varistors (MOV)
BS 219	Specification for soft solders
BS 2572	Specification for phenolic laminated sheet and epoxy cotton fabric laminated sheet
BS 2870	Rolled copper and copper alloys – sheet, strip and foil
BS 4800	Schedule of paint colours for building purposes
BS 7211	Electric cables-Thermosetting insulated and thermoplastic sheathed cables for voltages up to and including 450/750 V for electric power and lighting and having low emission of smoke and corrosive gases when affected by fire
BS EN 10270	Steel wire for mechanical springs Part 1: Patented cold drawn unalloyed spring steel wire
SLS 733	Electric cable- PVC insulated and PVC sheathed cables for voltages up to and including 300/500V, for electric power, lighting
SLS 734	13 A plugs, socket-outlets, adaptors and connection units Part 2: Specification for 13A switched and unswitched socket-outlets Part 3: Specification for adaptors Part 4: Specification for 13 A fused connection units Part 5: Specification for fused conversion plugs
SLS 948	Three-pin plugs sockets-outlets and socket-outlet adopters
SLS 963	Degrees of protection provided by enclosures (IP code)
SLS 1000	Switches for household and similar electrical installations- Part1: General requirements

- SLS 1185 Electric cable- Single-core unsheathed heat resisting cables for voltages up to and including 450/750V, for internal wiring
- SLS 1259 Sri Lankan standard voltages
- SLS 1310 Boxes for flush mounting of electrical accessories
- SLS 1352 Electric cables – Flexible cables rated up to 450/750V, for use with appliances and equipment intended for industrial and similar environments
- SLS 1504 Electric cables – Low voltage energy cables of rated voltages up to and including 450/750 V (U0/U)
- Part 1: General requirements
- Part 2-11: Cables for general applications – Flexible cables with thermoplastic P V C insulation
- Part 2-12: Cables for general applications – Cables with thermoplastic PVC insulation for extensible leads
- Part 2-21: Cables for general applications – Flexible cables with crosslinked elastomeric insulation
- Part 2-71: Cables for general applications – Flat tinsel cables (cords) with thermoplastic PVC insulation
- SLS 1533 Specification for general purpose fuse links for domestic and similar purposes (primarily for use in plugs)

3 TERMS AND DEFINITIONS

For the purposes of this part of standard the following terms and definitions apply.

NOTE: *Where the terms voltage and current are used, they imply r.m.s. values, unless otherwise stated.*

3.1 plug: A portable fused device having projecting pins designed to engage with the contacts of a corresponding socket- outlet. A plug also incorporates means for the electrical connection and the mechanical retention of a suitable flexible cable.

3.2 rough use plug: A plug designed to withstand severe mechanical handling.

NOTE: *Rough use plugs are identified by additional marking in accordance with 7.1 c). They are not intended for gross misuse. for instance, a plug should not be withdrawn from a socket-outlet by pulling on the attached flexible cable.*

3.3 rewirable plug: A plug so constructed that a flexible cable can be fitted or replaced using general purpose tools.

3.4 non-rewirable plug: A plug so constructed that it forms a complete unit with the flexible cable which cannot be replaced after assembly by the manufacturer of the plug.

NOTE: *See also 12.6.*

3.5 moulded-on plug: A non-rewirable plug, the manufacture of which is completed by insulating material moulded around pre-assembled component parts and the terminations of the flexible cable.

3.6 fused plug: A plug having provisions for a replaceable cartridge fuse link.

3.7 terminal: A means by which the user can make an electrical connection between the appropriate flexible cable and the conducting parts of the plug without the use of special purpose tools.

3.8 screw-type terminal: A terminal in which the connection is made directly by means of screws or nuts of any kind or indirectly through an intermediate metal part such as a washer, clamping plate or anti-spread device on which the screw bears directly.

NOTE: *The following are examples of screw-type terminals.*

a) *A pillar terminal is a terminal in which the conductor is inserted into a hole or cavity, where it is clamped under the shank screw or screws.*

b) *A screw terminal is a terminal in which the conductor is clamped under the head of the screw.*

c) *A stud terminal is a terminal in which the conductor is clamped under a nut.*

3.9 clamp type (screwless) terminal: A terminal for the connection and subsequent disconnection of one or more conductor (s), the connection being made directly or indirectly by means of springs, wedges or the like.

3.10 terminations: A means by which an electrical connection can be made between the appropriate flexible cable and the conducting part of the plug using special purpose tools. e.g. soldering, Welding, crimping.

3.11 fuse carrier: A movable or removable part designed to carry, retain, cover and / or remove the fuse link.

3.12 type test: A test or series of tests made on a type test sample, for the purpose of checking conformity of the design of a given product with the requirements of the relevant standard.

3.13 type test sample: A sample consisting of one or more similar units or specimens submitted by the manufacturer or responsible vendor for the purpose of a type test.

3.14 accessible external surfaces of a plug: All surface which can be touched by test probe B of IEC 61032 when the plug is in full engagement with a corresponding socket- outlet.

3.15 engagement surface of a plug: That surfaces which cannot be touched by test probe B of IEC 61032 when the plug is in full engagement with a corresponding socket-outlet.

3.16 live parts: Current – carrying parts and those metal parts in contact with them during normal use.

NOTE: *Metal parts of the earthing circuit are not considered to be current-carrying parts.*

3.17 fine wire thermocouple: A thermocouple having wires not exceeding 0.3 mm in diameter.

3.18 calibrated link: A calibrated heat source for use in place of a fuse link during temperature rise tests.

3.19 indicator lamp (pilot lamp): A lamp or similar device which illuminates to indicate that the plug is energized.

3.20 resilient material: A material having the inherent capability of regaining or substantially regaining its original form when deforming loads are removed.

3.21 creepage distance: Shortest distance along the surface of the insulating material between two conductive parts.

3.22 clearance: Shortest distance in air between two conductive parts.

3.23 insulated shutter opening device (ISOD): Protrusion from the engagement surface of the plug, in place of a brass earth pin, made of insulating material having dimensions similar to those of a brass earth pin.

3.24 basic insulation: Insulation applied to live parts to provide basic protection against electric shock.

NOTE: *Basic insulation does not necessarily include insulation used exclusively for functional purposes.*

3.25 supplementary insulation: Independent insulation applied in addition to basic insulation, in order to provide protection against electric shock in the event of failure of basic insulation.

3.26 reinforced insulation: Single insulation system applied to live parts, which provides a degree of protection against electric shock equivalent to double insulation under the conditions specified in the relevant standard.

3.27 functional insulation: Insulation between conductive parts which is necessary only for the proper functioning of the equipment.

3.28 class I: Method of protection against electric shock which does not rely on basic insulation only, but which includes means for the connection of exposed conductive parts to a protective conductor in the fixed wiring of the installation.

3.29 class II: Method of protection against electric shock which does not rely on basic insulation only, but in which additional safety precautions, such as double insulation or reinforced insulation are provided, there being no provision for protective earthing or reliance upon installation conditions.

NOTES:

1) *such a method may be one of the following.*

a) *Equipment having a double and substantially continuous enclosure of insulation material which envelopes all metal parts with the exception of small parts such as name plates, screws and rivets which are isolated from live parts by insulation at least equivalent to reinforced insulation. Such equipment is called “insulated encased Class II equipment”.*

- b) *Equipment having a substantially continuous enclosure of metal, in which double insulation is used throughout, except for those parts where reinforced insulation is used. Such equipment is called “metal encased Class II equipment”.*
- c) *Equipment that is a combination of types a) and b) above.*
- 2) *The enclosure of an insulation encased Class II appliance may form a part or whole of the supplementary insulation, or reinforced insulation.*
- 3) *If an appliance with double insulation and/or reinforced insulation throughout has an earthing terminal or an earthing contact, it is of Class I construction.*
- 4) *class II appliances may have parts in which protection against electric shock relies on operation at safety extra-low-voltage (SELV).*

3.30 insignificant mass: Insufficient combustible mass to constitute a fire hazard.

NOTE: *Parts of insignificant mass are usually less than 2 g.*

3.31 small parts: parts where each surface lies completely within a circle of 15 mm diameter or where some of the surface lies outside the 15 mm diameter circle but in such a way that it is not possible to place a circle of 8 mm diameter on any of this remaining surface.

NOTE: *More information concerning small parts can be found in IEC 60695-2-11.*

3.32 switched plug: A plug with associated switch or switches to disconnect the supply to the line terminal/ termination or to both line and neutral terminals/ terminations.

3.33 actuating member: that part which is moved, e.g. pulled, pushed or turned by the user, to operate the switch mechanism of a switched plug.

4 CONDITIONS OF USE

4.1 General

Plugs shall be so designed and constructed that in normal use their performance is reliable and minimizes the risk of danger to the user or to the surroundings. Such plug shall be capable of meeting all the relevant requirements and tests specified in this part of **SLS 734**. Plugs shall not be used for the connection of electrical power generators to socket-outlets.

4.2 Plug shall be suitable for use under the following conditions:

- a) an ambient temperature in the range -5 °C to +40 °C, the average value over 24 h not exceeding 35 °C.

NOTE: *Under normal conditions of use, the available cooling air is subject to natural atmospheric variations of temperature and hence the peak temperature occurs only occasionally during the hot season, and on those days when it does not persist for lengthy periods.*

- b) a situation not subject to exposure to direct radiation from the sun or other source of heat likely to raise temperatures above the limits specified in a);
- c) an altitude not exceeding 2 000 m above sea level;
- d) an atmosphere not subject to abnormal pollution by smoke, chemical fumes, rain, spray prolonged periods of high humidity or other abnormal conditions. This is equivalent to pollution degree 2, see Annex **E**, and overvoltage Category **III**, see Annex **D**.

5 GENERAL CONDITIONS FOR TYPE TESTING

5.1 All tests shall be type tests.

Unless otherwise specified in this part of **SLS 734** , the plugs shall be tested as delivered by the manufacturer or responsible vendor and under normal conditions of use, at an ambient temperature of $20\text{ °C} \pm 5\text{ °C}$ and after being conditioned at normal laboratory temperature and humidity levels for at least four days.

The plug used for the tests shall be representative of normal production items in respect of all details which may affect the test results.

Incorporated electronic components shall conform to their relevant standards and their incorporation shall not introduce a non-conformity with **SLS 734 Part 1** (see Annex **G**). Conformity shall be checked by inspection of component conformity evidence and the tests of **SLS 734 Part 1**.

Non-rewirable plugs shall be supplied with an appropriate flexible cable which shall be at least 1 m long. Plug shall be deemed to conform if no sample fails in the complete series of tests given in Table 1.

TABLE 1 - Schedule of tests

Sequence (1)	Sample (2)	Test (3)	Clause number (4)
1	3	Inspection, measurement, gauging and manipulation	5, 6, 7, 11.1, 9.1, 9.2, 9.4, 12.1, 12.2, 12.3, 12.4, 12.5, 12.9, (12.9.1, 12.9.2, 12.9.3 and 12.9.6 only), 12.13, 12.14, 12.15, 12.16, 18.2, 18.3, 18.4, 18.6,8 (except Annex C) 20
2	3	General	5, 9.3, 18.1, 12.12, 12.17.2, 12.17.3, 12.17.2
3	3		5, 13.2, 12.8, 18.5, 12.17.4
4	3		5, 13.1, 14.1, 15, 16, 12.18.1, 17, 19, 12.7, 10.1, 11.12, 12.10, 12.6, 12.11
5	3*		5, 12.9.4.1 or 12.9.4.2
6	3	Additional tests for rewirable plugs with clamp type (screwless) terminals	5, 13.1, 20.1
7	3		5, 11.10, 11.11
8a	9	Additional tests for plugs with nickel plated brass pins, non-solid pins and/or ISODs	5, 12.9.5
8b	3	Additional tests for plugs fitted with ISOD	5, 12.9.4.3
9	3	Materials	5, 21
10	3		5, 22.2, 8.2 (Annex C only)
11	3		5, 23
12	3	Positive break (switched plugs)	5, 12.1, 17.2
13	3	Overloads	5, 13.1, 25
14	3	Cyclic loading (plugs for EV)	5, 26

NOTES:

1) *The order of tests given in sequence 1 is preferred but not mandatory except where required within the text of the appropriate clause.*

2) **denotes that an additional three samples will be required for plugs with non-solid pins.*

If one sample fails in a complete series of tests given in Table 1, then plugs of that type shall be deemed to have failed to conform to this part of **SLS 734**, unless the plug is shown to be not representative of normal production or design, in which case a further type test sample shall be submitted to the test or tests in that particular group. If there is no failure in these retest then plugs of that type shall be deemed to conform to this part of the standard.

If more than one sample fails in the complete series of tests given in Table 1, then plugs of that type shall be deemed not to conform to this part of **SLS 734**.

NOTE: *For type testing, all tests have been included in the test schedule and should be performed in the specified order. References to carrying out specific tests in various clauses are not intended to indicate a sequence of testing different to that in the schedule and should not be conducted as separate additional tests.*

5.2 All inspections and tests, of any one classification (see 6), shall be carried out as specified in the clauses listed in Table 1 on the number of samples in the sample column and in the order given.

5.3 Gauges in accordance with Figure 6 shall be considered to conform to the dimensional requirements if the results the measured values are within the specified dimensions and the uncertainty of measurement at not less than 95 per cent confidence level does not exceed $\pm 0.005\text{mm}$

6 CLASSIFICATION

Plug shall be classified as follows:

- a) rewirable or non-rewirable;
- b) switched or unswitched;
- c) for normal use or rough use;
- d) for electric vehicle (EV) charging;
- e) fitted with screw or clamp type (screwless) terminals;
- f) for non-rewirable plugs for Class II applications only, fitted with an un-terminated brass earth pin or ISOD.

7 MARKING AND LABELLING

7.1 Plugs shall be legibly and durably marked with the following information, which shall not be placed on screws, removable washers or other easily removable parts, or upon part intended for separate sale:

- a) either the name, trade mark or identification mark of the manufacturer or responsible vendor, which may be duplicated on a removable fuse carrier;
- b) for rough use plugs the rated current shall be followed by “/A”;
- c) on rewirable plugs the terminals intended for the connection of the various conductors shall be identified by the symbols given in 7.5;
- d) the words “FUSE” or “FUSED” or the symbol (as given in 7.5) on the external accessible surface of a plug;
- e) all rewirable plugs shall be marked on the engagement surface with the rated current. All non-rewirable plugs shall be marked with the rated current of the fuse link fitted, which shall not exceed the value given in Table 2 for the appropriate size of flexible cable;

- f) plugs with clamp type (screwless) terminals shall be marked to show the length of conductor insulation to be removed before fitting the conductor in the terminal; and
- g) plugs for electric vehicle charging, the rated current shall be followed by “/EV”.

7.1.1 Conformity shall be checked by inspection and by rubbing the marking for approximately 15 s with a cloth soaked in water, and again for approximately 15 s with a cloth soaked in an aliphatic solvent hexane with a content of aromatics of maximum 0.1 per cent by volume, a kauri-butanol value of 29, an initial boiling point of approximately 69 °C, and relative density of approximately 0.68. The marking shall remain legible. Markings produce by an engraving or molding process shall be deemed to conform without test.

7.2 Rewirable plugs shall have a removable tag or label indicating the rating of the fuse link fitted e.g. “Fitted with “X” ampere fuse” (where “X” denotes the rating of the fuse link).

7.2.1 Conformity shall be checked by inspection.

7.3 Except where a plug fitted with a flexible cable is supplied direct to a manufacturer for incorporation in other equipment, the free end of such as assembly shall have a label attached which shall include the following:

- a) the statement: “The Flexible cable of this plug must be connected to a piece of equipment before being plugged into a socket-outlet”;
- b) the maximum rating , in amperes, of the equipment to which it may be fitted (as given in Table 2);
- c) the colour code of the cores of the flexible cable as follows:

“IMPORTANT. Wires in the mains lead are colored in accordance with the following code:

Green-and-yellow	Earth (if any)
Blue	Neutral
Brown	Line;

- d) if the plug is fitted with a 2-core flexible cable, the following statement:

“This lead must not be used with equipment requiring the protection of an earth continuity conductor.”

7.3.1 Conformity shall be checked by inspection.

7.4 Rewirable plugs shall be provided with adequate instructions for the safe connection of the appropriate flexible cables, including clear instructions for the removal of insulation from the conductors.

Plugs incorporating clamp type (screwless) terminals shall be supplied with information indicating that plug is fitted with clamp type (screwless) terminals and containing clear instructions for the removal of insulation from the conductors and for the effective connection and disconnection of conductors.

7.4.1 Conformity shall be checked by inspection.



7.5 Symbols shall be as follows:

Amperes A

Volts V

Line L

Neutral N

*Earth  (preferred) or 

NOTES:

1) the letter 'E' may be used in addition to either of these symbols.

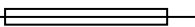
*fuse 

2) *IEC 60417-DB* gives details of symbols marked with*

TABLE 2 - Rated current and maximum fuse rating in normal use, and load for flexing and cable grip tests related to size of flexible cable

Flexible cable nominal cross-sectional area mm ²	Rated current ^{d)} A	Test current 0.4 A A	Fuse rating A	Load for flexing test +2%, -0% kg	Cable grip test +2%, -0% kg	Torque ^{b)} Nm
(1)	(2)	(3)	(4)	(5)	(6)	(7)
0.5	3	3.5	3 (5) ^{a)}	1	3	0.15
0.75	6	7	7(13) ^{a)}	1	3	0.20
1(0.75) ^{c)}	10	11	10(13) ^{a)}	2	3	0.25
1.25(1) ^{c)}	13	14	13	2	6	0.30
1.5	13	14	13	2	6	0.35

- a) The figure in brackets indicates the fuse rating when a non rewirable plug is used with certain types of appliances where the use of the higher rated fuse link is necessary because of their characteristics. Portable socket- outlets are not considered to be appliances and therefore the higher rated fuse cannot be used.
- b) The recording of a measured value of torque in accordance with this table is considered to conform to this part of **SLS 734** on condition that the uncertainty of measurement at not less than 95 per cent confidence level does not exceed ± 10 per cent.
- c) The figure in brackets indicates the flexible cable size which may be used for cable sets when non- rewirable plug are used with a maximum flexible cable length of 2 m.
- d) Non –rewirable plugs may have a rated current appropriate to a smaller cable size than that fitted. (e.g. a plug rated at 3 A may be fitted with an 0.75 mm cable). In such cases, load and torque parameters for testing shall relate to the size of cable fitted and the test current shall relate to the rated current of the plug.

8 CLEARANCES, CREEPAGE DISTANCES AND SOLID INSULATION

Plugs shall be constructed so that the clearances, creepage distance and solid insulation are adequate to withstand the electrical stresses taking into account the environmental influences that may occur. Clearances, creepage distances and solid insulation shall conform to the relevant requirements of **8.1, 8.2, 8.3** and **8.4** the distance between lead wires in the pinch of a neon lamp with external resistor shall be a minimum of 1 mm.

Plug conforming to the requirements for basic insulation shall be deemed to meet the requirements of this clause. If the manufacturer declares insulation level exceeding basic insulation then the plug shall be tested accordingly.

NOTES:

- 1) *The requirements and tests are based on IEC 60664-1.*
- 2) *Product insulation consists of basic insulation and protective earthing as required by IEC 61140 for Class I equipment. Mechanical strength equivalent to that which would be provided by reinforced insulation as listed in IEC 61140 is achieved in SLS 734 products through specific mechanical and material tests.*

8.1 Clearances

Plug energized directly from the low voltage supply fall into Over voltage Category **III**.

The clearances shall withstand the rated impulse voltage declared by the manufacturer considering the rated voltage and the Overvoltage Category as given in Annex **D** and the pollution degree declared by the manufacturer in accordance with Annex **E**.

For the measurements, all parts which may be removed without the use of a tool are removed and moveable parts which can be assembled in different orientations are placed in the most unfavorable position.

NOTE: *Moveable parts are, for example, hexagonal nuts, the position of which cannot be controlled throughout an assembly.*

8.1.1 Clearances for basic insulation

The clearances for basic insulation shall not be less than the values given in Table **3** except as described below.

Smaller unspecified clearances (except those values marked in Table **3** with footnote “b”) may be used if the plug meets the impulse withstand voltage test of Annex **F** at the impulse voltage specified in Annex **D** but only if the parts are rigid or located by mouldings or if the construction is such that it is unlikely that distances will be reduced by distortion or by movement of the parts during mounting, connection and normal use.

Conformity shall be checked by inspection, and if necessary by measurement, or by the test of Annex **F**. If clearance distances are to be measured, this shall be carried out in accordance with Annex **B**.

8.1.2 Clearances for functional insulation

The clearances for functional insulation shall not be less than the values specified for basic insulation in **8.1.1**.

Conformity shall be checked by inspection, and if necessary by measurement, or by the test of Annex **F**.

If clearance distances are to be measured, this shall be carried out in accordance with Annex **B**.

8.1.3 Clearances for supplementary insulation

The clearances for supplementary insulation shall not be less than the values specified for basic insulation in **8.1.1**.

Conformity shall be checked by inspection, and if necessary by measurement, or by the test of Annex **F**.

If clearance distances are to be measured, this shall be carried out in accordance with Annex **B**.

TABLE 3 - Minimum clearances for basic insulation

Rated impulse withstand voltage kV ^{a)}	Minimum clearances in air up to 2000 m above (mm)
0.33	0.2 ^{b)}
0.50	0.2 ^{b)}
0.80	0.2 ^{b)}
1.5	0.5
2.5	1.5
4.0	3.0
6.0	5.5

a) See Annex **D**. This voltage is:

- for function insulation : the maximum impulse voltage expected to occur across the clearance ;
- or basic insulation directly exposed to or significantly influenced by transient overvoltage from the low voltage mains: the rated impulse withstand voltage of the plug;
- for other basic insulation: the highest impulse voltage that can occur in the circuit.

b) Minimum clearance values are based on **IEC 60664-1**.

8.1.4 Clearances for reinforced insulation

The clearances for reinforced insulation shall be not less than the values specified for basic insulation in **8.1.1** but using the next higher step for rated impulse withstand voltage given in Table **3**. This requirement shall not be applied to the sleeves of the plug pins.

Conformity shall be checked by inspection and measurement, or by the test of Annex **F**.

8.1.5 Contact gap

The minimum contact gap shall be 1.2 mm in the open position, except for electronic switches covered by Annex **G.4**.

Conformity shall be checked by measurement.

8.2 Creepage distances

The creepage distances shall be dimensioned for the voltage, which is expected to occur in normal use taking into account the pollution degree, and the material group as declared by the manufacturer.

For the measurements, all parts which may be removed without the use of a tool are removed and movable parts which can be assembled in different orientations are placed in the most unfavorable position.

NOTES:

- 1) *Moveable parts are, for example, hexagonal nuts, the position of which cannot be controlled throughout an assembly.*
- 2) *A creepage distance cannot be less than the associated clearance.*

Creepage distances are measured in accordance with Annex **B**.

The relationship between material group and between comparative tracking index (CTI) values and proof tracking index (PTI) values is as follows:

Material group I	$600 \leq \text{CTI/PTI}$
Material group II	$400 \leq \text{CTI/PTI} < 600$
Material group IIIa	$175 \leq \text{CTI/PTI} < 400$
Material group IIIb	$100 \leq \text{CTI/PTI} < 175$

The CTI or PTI values are determined in accordance with Annex **C**.

- 3) *For glass, ceramics and other inorganic materials which do not track, creepage distances need not be greater than their associated clearance.*

8.2.1 Creepage distances for basic insulation

The creepage distances for basic insulation shall not be less than the values given in Table 4. Conformity shall be checked by measurement.

TABLE 4 - Minimum creepage distances (mm) for basic insulation

Rated voltage ^{a)} V (r.m.s.) Up to and including	Pollution degree 2 ^{b)} Material group			Pollution degree 3 ^{b)} Material group			
	(1)	(2)	(3)	(4)	(5)	(6)	(7)
---	I	II	IIIa/IIIb	I	II	IIIa	
250	1.3	1.8	2.5	3.2	3.6	4.0	

a) This voltage is the voltage rationalized through Table **F.3a** and Table **F.3b** of **IEC 60664-1** based on the nominal voltage of the supply system.

b) Details of pollution degrees are given in Annex **E**.

8.2.2 Creepage distances for functional insulation

The Creepage distances for functional insulation shall not be less than the values specified for basic insulation in 8.2.1.

Conformity shall be checked by measurement.

8.2.3 Creepage distances for supplementary insulation

Creepage distances for supplementary insulation shall not be less than the values specified for basic insulation in 8.2.1.

Conformity shall be checked by measurement.

8.2.4 Creepage distances for reinforced insulation

The Creepage distances for reinforced insulation shall not be less than those derived from twice the distances specified for basic insulation in Table 4.

This requirement shall not be applied to the sleeves of the plug pins.

Conformity shall be checked by measurement.

8.3 Solid Insulation

Solid insulation for basic, functional, supplementary and reinforced insulation shall be capable of withstanding electrical stresses which can occur in normal use.

No minimum thickness is specified for solid insulation.

8.3.1 Conformity shall be checked by tests in accordance with 14.1.3 using the values given in Table 5.

TABLE 5 - Withstand voltages for insulation types

Insulation	Test voltages, V (r.m.s)
Functional Insulation	1 500
Basic Insulation	1 500
Supplementary Insulation	1 500
Reinforced Insulation	3 000

8.4 Requirements for printed wiring boards and equivalent construction

Printed wiring boards and equivalent construction shall conform to **IEC 60664 -5**. Where coating potting or moulding is used articles shall conform to **IEC 60664-3**.

9 ACCESSIBILITY OF LIVE PARTS

9.1 Live parts of plugs shall not be accessible when the plugs are wired as in normal use and in full engagement in a corresponding socket-outlet.

Removal of detachable fuse carriers shall not result in live parts becoming accessible when the plug is in full engagement with the socket-outlet or the socket-outlet portion of an adaptor.

9.1.1 Conformity shall be checked by the application of test probe 12 of **IEC 61032** applied with a force of 5_{-1}^0 N with rewirable plug fitted with a 2-core flexible cable as given in **SLS 1504-2-71** and non-rewirable plugs as supplied. Detachable fuse carriers shall be removed before this test is undertaken.

9.2 Plugs shall be designed and constructed so as to protect the user against accidental contact with live parts during insertion or withdrawal of plugs.

9.2.1 Conformity shall be verified by satisfying the dimensional and gauging requirements of this part of **SLS 734**.

9.3 Resilient covers of plugs shall be so designed and constructed that when assembled and wired as in normal use, there is not risk that, as a result of undue pressure, live parts could penetrate the cover or become so disposed as to reduce creepage distances and clearances below those given in **8**.

9.3.1 Conformity shall be checked by the following test (an example of a suitable apparatus is shown in Figure 2). The design of the apparatus shall be such that a steady force of 240_{-10}^0 N can be applied to those place where the possibility of a failure exists, the force being applied through a metal test pressure block as shown in Figure 3).

Each sample shall be subjected to the force at each chosen place in turn. During each application of force of $2\ 000\ V \pm 60\ V$ 50 Hz of substantially sinusoidal waveform is applied for 60_{+5}^0 s between all live parts bonded together and the metal test pressure block.

During the test no flashover or breakdown shall occur.

After the test it shall not be possible to touch live parts with test 11 of **IEC 61032** applied with a force of 30_{-2}^0 N.

9.4 Except for a plug fitted with a flexible cable supplied to equipment manufacturers for incorporation into their equipment, a plug supplied with a flexible cable shall have the free end encapsulated in insulating material.

9.4.1 Conformity shall be checked by inspection.

10 PROVISION FOR EARTHING

10.1 All accessible metal parts of plugs shall be in effective electrical contact with the earthing plug pin, except that metal parts on, or screw in or through, non-conducting material, and separated by such material, from current-carrying parts in such a way that in normal use they cannot become live, need not be in effective electrical contact with the earthing pin.

The earth pin shall be provided with a terminal or termination such as to provide a joint of low resistance with the earth conductor of a flexible cable.

Metal parts having an accessible surface coating of lacquer or enamel shall be tested as accessible metal parts

10.1.1 Conformity shall be checked by inspection and the following:

- a) for metal parts insulated from live parts, by the test described in **14.1.3**:
- b) for metal parts connected to an earthing terminal or earthing plug pin by the following test. A current of $25 \text{ A} \pm 0.75 \text{ A}$, derived from an a.c source having a no-load voltage not exceeding 12 V is passed for 60 ± 5 s between the remote end of the protective conductor of a 3-core flexible cable (cut to a length of $150 \text{ mm} \pm 5 \text{ mm}$ measured from the nearest edge of the earthing pin) and the remote end of the earthing plug pin and any accessible metal part intended to be earthed, taking account of the following:
- 1) for non-rewirable plugs the manufacturer's connection is tested as supplied, with the flexible cable cut to a length of $150 \text{ mm} \pm 5 \text{ mm}$ measured from the nearest edge of the earthing pin, precoiled flexible cable being extended before measurement.
 - 2) for rewirable plugs, 1.5 mm^2 flexible cable conforming to **SLS 1504-2-11** shall be used:
 - i) for screw-type terminals the clamping screw shall be tightened with a torque equal to two thirds of the appropriate value given in Table 6;
 - ii) for clamp type (screwless) terminals the connection shall be made in accordance with the manufacturer's instructions.

The resistance between the earthing terminals or termination and any other nominated metal part shall not exceed 0.05Ω .

TABLE 6 - Torque values for screws and nuts

Declared diameter of screw thread mm	Torque (see Note 1) For metal screws (see Note 2) Nm	For other metal screws and nuts Nm	For screws of insulating material Nm
(1)	(2)	(3)	(4)
Up to and including 2.8	0.2	0.4	0.4
Over 2.8, up to and including 3	0.25	0.5	0.5
Over 3, up to and including 3.2	0.3	0.6	0.6
Over 3.2, up to and including 3.6	0.4	0.8	0.6
Over 3.6, up to and including 4.1	0.7	1.2	0.6
Over 4.1, up to and including 4.7	0.8	1.8	0.9
Over 4.7, up to and including 5.3	0.8	2.0	1.0
Over 5.3, up to and including 6	-	2.5	1.25

NOTES:

- 1) *The recording of a measured value given in this table is considered to conform to this Part of SLS 734 on condition that the uncertainty at not less than 95 per cent confidence level does not exceed ± 10 per cent.*
- 2) *This column applied to metal screws without heads if the screw when tightened does not protrude from the hole, and to other metal screws which cannot be tightened by means of a screwdriver with a blade wider than the diameter of the screw.*

11 TERMINALS AND TERMINATIONS

11.1 Terminals and terminations shall provide for effective clamping and securing of conductors connected to them, so that efficient electrical connection is made.

11.1.1 Conformity shall be checked in accordance with **11.2** to **11.9**.

11.2 Rewirable plugs shall be provided with terminals as defined in **3.8** or **3.9**.

11.2.1 Conformity shall be checked by inspection.

11.3 Non-rewirable plugs shall be provided with soldered, welded, crimped or similar terminals; for all these methods of termination, not more than one strand of a 0.5 mm^2 conductor or two strands of other sized conductors shall be fractured during connection.

Screwed and “snap-on” terminals shall not be used. Crimped connections shall not be made on to pre-soldered flexible area is entirely outside the crimp.

A terminal or termination shall not be provided on an ISOD.

11.3.1 Conformity shall be checked in by inspection and measurement.

11.4 Terminals in rewirable plugs shall permit the connection, without special preparation, of flexible cables having nominal conductor cross-sectional areas of 0.5 mm^2 to 1.5 mm^2 .

11.4.1 Conformity shall be checked by inspection and fitting the appropriate conductors.

11.5 Where pillar terminals are used they shall have clamping screws of sufficient length to extend to the far side of the conductor hole. The end of the screw shall be slightly rounded so as to minimize damage to the conductors. The sizes of the conductor hole and the clamping screw shall be such that the clearance between each size of the major diameter of the clamping screw and the conductor hole does not exceed 0.4 mm.

11.5.1 Conformity shall be checked by inspection and measurement.

11.6 Terminal screws shall have a declared outside diameter of not less than 3 mm or be not smaller than 6 B.A. Thread cutting and/or thread forming screws shall not be used.

11.6.1 Conformity shall be checked by inspection and measurement.

11.7 Insulating barriers in rewirable plugs shall be an integral part so arranged that with the cable anchorage rendered inoperative and the earth or line conductors becoming detached from their respective terminals, there is negligible risk of the following:

- a) the earth conductor coming into contact with parts at line potential;
- b) the line conductor coming into contact with the line pin assembly.

11.7.1 Conformity shall be checked by inspection and by the following test.

The plug is wired as in normal use with a 0.5 mm^2 3-core flexible cable as given in **SLS 1504-2-11** in accordance with the manufacturer’s instructions. All terminals screws or nuts are tightened to the appropriate torque given in Table **6**.

A continuity indicating circuit operation at not less than 40 V shall be connected between the conductor and the other parts nominated. All terminal screws shall then be loosened and the cable anchorage rendered inoperative and the cover of the plug refitted. For plugs fitted with clamp type (screwless) terminals the conductor clamp shall be rendered inoperative. The flexible cable shall then be withdrawn from the plug at a rate not exceeding 50 mm/min, the direction of the pull being varied, until the earth core is pulled free of the plug. The test is made six times in all. For each new test a fresh section of the flexible cable is perpendicular to its major axis in a clockwise direction before fitting unless the design is such that this is not practicable. There shall be no contact between parts at line potential and the earth conductor or between the line conductor and line pin assembly, thus by passing the fuse link.

11.8 Rewirable plugs shall be designed so that they can be wired in a manner which prevents strain to the earth connection before the line and/or neutral connection when the cable anchorage is rendered inoperative.

11.8.1 Conformity shall be checked by inspection and manipulation using a plug wired in accordance with the manufacturer's instructions.

11.9 In rewirable plugs terminals shall be so located or shielded that should a strand of a flexible conductor escape when the conductors are fitted, there is negligible risk of accidental connection between live parts and accessible external surfaces, or of a stray strand by passing the fuse link.

11.9.1 Conformity shall be checked by inspection, and by the following test.

A length of insulation in accordance with the manufacturer's instructions is removed from the end of a flexible conductor having a normal cross-sectional area of 1.5 mm². One strand of the flexible conductor is left free and the other strands are fully inserted into and clamped in the terminal. The free strand is bent, without tearing the insulation back, in every possible direction, but without making sharp bends around barriers unless a bend is reproduced by the replacement of the cover.

The free strand of a conductor connected to a live terminal shall not:

- a) touch any metal part so as to bypass the fuse link;
- b) touch any metal part which is accessible or is connected to an accessible metal part; or
- c) reduce creepage distance and clearance to accessible surfaces to less than 1.3 mm.

The free strand of a conductor connected to an earthing terminal shall not touch any live parts.

11.10 Clamp type (screwless) terminals shall be so designed that they make electrical contact to the specified conductors, between metal surfaces with sufficient pressure, and without additional means to maintain the clamping pressure. They shall not cause undue damage to the conductors.

NOTE: *Conductors are considered to be unduly damaged if they show deep or sharp indentations.*

It shall be clear how the connection and disconnection of the conductors is intended to be effected.

The intended disconnection of a conductor shall require an operation to unlatch the clamp manually prior to removing the conductor.

11.10.1 Conformity shall be checked by the following.

- a) Inspection of three sample plugs.
- b) The following test is carried out on each terminals of the three set of L,N and E terminals supplied in the test sample. For the purposes of this test, terminals are removed from the test sample or alternatively supplied separately.

Tests are carried out on each line, neutral and earth terminals separately with individual flexible conductors, first with conductors having the largest cross-sectional area, and then with conductor having the smallest cross-sectional area, as specified in **11.4**.

Conductors are connected and disconnected five times, on each terminal, new conductors being used each time, except for the fifth time, when the conductors used for the fourth connection are reconnected at the same place.

For each insertion, the conductors are inserted so that adequate connection is obvious. After insertion, the conductor is subjected to a pull of 30 ± 2 N. The pull is applied in one smooth and continuous motion for 60 ± 5 s in a direction equivalent to that in which the conductor lies when the terminal is mounted in the plug.

During the application of the pull, the conductor shall not come out of the terminal. After these tests neither the terminals nor the clamping means shall have deteriorated in a manner impairing their further use and not more than one strand of a 0.5 mm^2 conductor or two strands of other sized conductors shall be fractured.

11.11 Clamp type (screwless) terminals shall be so constructed that incorrect fitting of the conductor is prevented.

11.11.1 Conformity shall be checked by inspection.

11.12 Clamp type (screwless) terminals shall be adequately located in the plug when assembled for normal use.

11.12.1 Conformity shall be checked by inspection, and by the mechanical strength test given in **19.1.3**.

12 CONSTRUCTION OF PLUGS

12.1 The disposition of the plug pins (including ISODs where applicable) shall be as shown in Figure 4.

12.1.1 Conformity shall be checked by inspection.

12.2 The outline of the plug shall not exceed the dimensions shown in Figure 4, for a distance of not less than 6.35 mm from the engagement surface and within these dimensions there shall be not axial projection from the engagement surface of the plug, except that at a distance more than 6.35 mm from the engagement surface the outline of the plug may exceed the dimensions shown in Figure 4, in the plane of the earth pin and in the plane of the flexible cable entry to facilitate the removal of the plug from the socket. Pin disposition,

length and body outline shall be checked by use of the gauge shown in Figure 6 in accordance with the following test. Pin and sleeve dimensions shall be checked by measurement and shall conform to Figure 4, except for non-solid pins and ISOD where the chamfers shall generally fall within the profiles of Figure 4, and their adequacy shall be checked by the tests of 12.9.5. ISODs shall be of generally rectangular cross-section. "I" sections are not permitted although castellated cross-sections are permitted provided their dimension conform Figure 5 and all the other requirements of the standard are met.

The maintenance of these dimensions shall not rely on the terminal screws.

Plug fitted with an ISOD shall conform to all the dimensions specified in Figure 4, with the exception of the ISOD width which shall be 4.05 mm maximum and 3.90 mm minimum and its height which shall be 8.05 mm maximum and 7.75 mm minimum.

NOTE: *Preferred plug profile dimensions to assist with compatibility and enclosed socket-outlets are given in Annex I.*

12.2.1 Conformity shall be checked by inspection, measurement and by the use of the gauge shown in Figure 6.

For the gauging test rewirable plugs shall be fitted with a 3-core 1.5 mm² flexible cable as given in **SLS 1504-2-11**. Non-rewirable plugs shall be tested as delivered.

With the gauge in an approximately vertical position and the engagement surface of the plug and the gauge parallel to each other, the line and neutral pins shall be entered into the gauge for a distance not exceeding 2 mm. The plug shall then enter the gauge fully when a force of 10 N or less is applied to the centre of the plug at right angles to the engagement surface and without any additional force being applied to the pins to bring them into alignment.

In the case of plugs with ISODs, due to the flexibility of plastic materials some additional alignment of the ISOD is allowed when inserting into the Figure 6 gauge. Where alignment cannot be maintained the test given in Clause 12.8 of **SLS 734 Part 2**, shall be applied and the maximum withdrawal force from a socket-outlet conforming to **SLS 734 Part 2** shall not exceed 36 N.

12.3 No part of a line or neutral pin shall be less than 9.5 mm from the periphery of the plug measured along the engagement surface.

12.3.1 Conformity shall be checked by measurement.

12.4 A fuse link conforming to **SLS 1533** shall be provided within the body of the plug and the fuse link shall be mounted in appropriate contacts only between the line terminals or termination and the corresponding plug pin in such a way that it cannot be displaced when the plug is in use. The design shall be such that the fuse carrier is replaced and firmly secured in position.

A manufacturer of plugs may supply plugs in a plugs in part assembled form ,with or without an appropriate fuse, direct to a manufacturer for incorporation in other equipment, provided that when assembled the complete plug conforms to this part of **SLS 734**.

It shall be impossible to replace the fuse link in a plug unless the plug is completely withdrawn from the socket outlet.

For non- rewirable plugs the current rating of the fuse link shall not exceed the value given in Table 2 for the appropriate size of the flexible cable.

12.4.1 Conformity shall be checked by inspection.

12.5 In non- rewirable plugs where the fuse link is retained by means of a fuse carrier, this device shall be either:

- a) non- detachable during normal replacement of the fuse link; or
- b) readily identifiable in relation to its plug by means of marking.

12.5.1 Conformity shall be checked by inspection.

12.6 The base and cover of non-rewirable plugs shall be permanently attached to each other, such that the flexible cable cannot separated without marking the plug permanently useless, and the plug cannot be opened by hand or by using a general purpose tool, for example, a screwdriver. A plug shall be considered to be permanently useless when, for reassembling, the plug parts or materials other than the original have to be used.

The base and cover of rewirable plugs shall be firmly secured to each other. It shall not be possible to remove the cover unless the plug is completely withdrawn from the socket outlet. Any fixing screws shall be captive.

12.6.1 Conformity shall be checked by inspection. And by the following tests as applicable.

- a) Each plug cover fixing screw has a pull of 60^{0}_{-2} N exerted upon it for 60^{+5}_{0} s whilst the surface temperature of the product is $70^{\circ}\text{C} \pm 5^{\circ}\text{C}$. The test is carried out using apparatus similar to that shown in Figure 7 and for the test the plug cover and apparatus are placed in an oven until they reach the required temperature.

At the end of the test any screw thread shall be serviceable and any insert shall not have moved to such an extent that correct assembly of the plug is prevented.

- b) For rewirable plugs having cover fixed by means other than screw and for non-moulded-on, non-rewirable plugs, all the plugs are clamped together in a suitable jig and subjected to a pull of 60^{0}_{-2} N whilst suspending the cover by means of a 'nest' to suit the plug cover profile. The test is carried out in an oven at a temperature of $70^{\circ}\text{C} \pm 5^{\circ}\text{C}$ and the pull applied for 60^{+5}_{-0} s after the temperature has been attained.

After the test it shall not be possible to touch live parts with the test pin shown in Figure 1 applied with a force of 5^{0}_{-1} N.

- c) Non- moulded-on, non-rewirable plugs are tested with the flexible cable supplied. The plug pins are clamped in the vertical position using a suitable jig with the plug pins uppermost. The plug lead fitted shall be extended with a similar flexible cable resulting in a total length of 1 m in such a way that any joint has negligible effect and a weight of $3^{+0.06}_{0}$ kg fixed to the end. With the weight initially held 0.5 ± 0.05 m from the end of cable anchorage, and at the same height, the weight is allowed to fall freely. This test shall be carried out five times.

After this test the plug cover shall be in place and show no damage. If the flexible cable becomes detached during this test but the plug cover remains in place and shows no damage the plug shall be deemed to have passes this test.

Conformity shall be checked by inspection.

12.7 Plugs shall be so designed and constructed that they cannot readily be deformed to allow access to live parts.

12.7.1 Conformity shall be checked by inspection and by the following test.

Immediately after the test described in **15**, test probe 11 of **IEC 61032** is applied to the accessible surface of the plug with a force of 30_{-5}^0 N. It shall not be possible to touch live parts.

12.8 For non-rewirable plugs, means shall be provided to prevent loose strands of a conductor or current-carrying parts from reducing the minimum insulation thickness requirements between such parts and all accessible external surfaces of the plug.

12.8.1 Conformity shall be checked by inspection and the test described in **14.2**.

12.9 Materials other than brass or nickel plated brass shall not be used in the construction of line and neutral plug pins except for sleeves of pins as specified in **12.16** plug pins and ISODs shall conform **12.9.1** Non-solid pins shall conform to **12.9.2**.

12.9.1 All exposed surfaces of plug pins shall be smooth and free from burrs or sharp edges and other irregularities which could cause damage or excessive wear to corresponding socket contacts or shutters.

12.9.1.1 Conformity shall be checked by inspection.

12.9.2 Those surface of the non- solid plug pins which are visible when the plug is correctly assembled shall be free of apertures.

12.9.2.1 Conformity shall be checked by inspection.

12.9.3 All seams and joints of non-solid pins shall be closed over their entire length.

12.9.3.1 Conformity shall be checked by inspection and in case of doubt by the following test.

Push a steel test probe of 0.2 mm diameter into all seams and joints. Check that the test probe does not enter into any seam or joint to a depth greater than the thickness of the material from which the plug pin is formed.

12.9.4 Plug pins and ISODs shall have adequate strength to withstand the stresses of normal use.

12.9.4.1 For solid pins, conformity shall be checked by the following test.

Position a pin on the fixed anvil of the apparatus, as shown in Figure **21** and Figure **22** with its contact surfaces in the horizontal plane. Apply a force of 1100_{-10}^0 N to the movable anvil by any convenient method such that the pin is strained at a rate not exceeding 10 mm/min.

The test shall be made separately on the line neutral and earth pins applying the load perpendicular to the major axis surfaces of the pins.

After this test the plug shall fit the gauge shown in Figure 6 when used in the manner described in 12.2.1.

12.9.4.2 For non-solid pins conformity shall be checked by the following tests.

- a) Position a pin on the fixed anvil of the apparatus, as shown in Figure 21 and Figure 22 with its contact surfaces in the horizontal plane. Bring the movable anvil to rest against the upper surface of the pin. Apply a force of 800_{-10}^0 N to the movable anvil 50 times without impact.

The test shall be made separately on the line, neutral and earth pins applying the load perpendicular to the major axis surfaces of the pins. If there is a joint or seam in one of the major axis surfaces of a pin then the test shall be made twice. The seam or joint shall face the moving anvil for the first test and shall face the fixed anvil for the second test.

After the test the pins shall conform to 12.9.2 and 12.9.3 and the plug shall fit gauge shown in Figure 6 when used in the manner described in 12.2.1.

- b) Separate samples shall be used for the following test.

Position a pin on the fixed anvil of the apparatus, as shown in Figure 21, with the widest surface in the horizontal plane. Bring the movable anvil to rest against the upper surface of the pin. This quiescent position shall be taken as the datum point. Apply a force to the movable anvil by any convenient method such that the pin is strained at a rate not exceeding 10 mm/min. Measure the applied force when the movement of the anvil from the datum point reaches $1.5_{-0.1}^0$ mm. The test shall be made separately on the line, neutral and earth pins applying the load perpendicular to the major axis surfaces of the pins if there is a joint or seam in one of the major axis surfaces of a pin then the test shall be made twice. The seam or joint shall face the moving anvil for the first test and shall face the fixed anvil for the second test. The force shall be not less than 1 100 N.

12.9.4.3. For ISODs, Conformity shall be checked by following test.

Position the ISOD on the fixed anvil of the apparatus as shown in Figure 21 with the widest surfaces in the horizontal plane bring the moveable anvil to rest against the upper surface of the ISOD. The quiescent position shall be taken as the datum points apply a force to the moveable anvil by any convenient method such that the ISOD is strained at a rate of (10 ± 2) mm/min.

A force of 400_{-0}^{+10} N is applied and the measured deflection shall not exceed 1.5 mm. The ISOD shall not be broken or show cracks that are visible with normal or corrected vision without additional magnification.

After the test the plug shall fit the Figure 6 gauge when used in the manner described in 12.2.1 with a force not exceeding 20 N.

When testing a plug fitted with an ISOD due to the flexibility of plastic materials some additional alignment of the ISOD is allowed when inserting into the Figure 6 gauge. Where alignment cannot be maintained the test of Clause 12.8 of SLS 734 Part 2 shall be applied and the maximum withdrawal force from a socket- outlet conforming to SLS 734 Part 2 shall not exceed 36 N.

12.9.5 Plug with nickel plated brass pins, non-solid pins and / or ISODs shall not cause excessive wear to socket contacts or shutters of socket-outlets in accordance with SLS 734 Part 2. For plugs with nickel plated brass pins and /or non-solid pins conformity shall be checked by 12.9.5.1 for plugs with ISODs.

Conformity shall be checked by 12.9.5.2.

12.9.5.1 Conformity shall be checked by the following tests.

The test is carried out with plug with nickel plated brass pins and /or non-solid pins and three different types of new socket- outlets in accordance with SLS 734 Part 2. Two types of the socket-outlet shall have the shutters operated by the earth pin, one of which is preferably operated by all three pins and one of which is preferably operated by line and neutral pins only.

The combination of rewirable plugs having nickel plated brass pins and/or non-solid pins and each type of socket-outlet as described shall make and break a current of $13 \text{ A} \pm 0.4 \text{ A}$, non-rewirable plugs shall be tested with the rated current appropriate to the flexible cable given in Table 2, at $250 \text{ V} \pm 10 \text{ V}$ a.c 15 000 times (30 000 movements) in a substantially non-inductive circuit.

Each plug is inserted into and withdrawn from the socket- outlet at a rate of six insertions and six withdrawals per minute, the speed of travel of the plug being approximately 150 mm/s. The periods during which the plug is inserted and withdrawn shall be approximately equal. The plug pins are renewed or a new plug is used after each 5 000 insertion and withdrawals. For the purpose of this test no lubrication shall be applied to the pins of the plug or the socket-outlet contacts.

After the test the shutters of the socket-outlets shall be operating satisfactorily, the socket contacts safely shielded and the socket-outlets shall be in accordance with 9.1, 15, 14, 12.4.1a) 10.2, 12.6, 12.7 and 12.8 of SLS 734 Part 2 or the plug pin to socket contact measurements increased by 50 per cent. The pins of the plug shall remain intact with no openings in the surface, joints or seams which will accept the probe specified in 12.9.3. There shall be no visible evidence of peeling or flaking of plating.

12.9.5.2 Conformity shall be checked by the following.

Using a selection of three different makes of rewirable plugs conforming to this standard and three different make of unswitched socket- outlets conforming to SLS 734 Part 2, selected to represent different earth contact designs, the earth resistance between the earthing plug pin and the earthing socket contact of the socket- outlets shall be established in accordance with Clause 10.2.1b) of SLS 734 Part 2.

All socket- outlets shall be of the type where the earth pin or ISOD of a plug inserted into the socket-outlet operates the shutter mechanism.

The test shall be made using a separate sample being inserted into and withdraw from the socket-outlet at a rate six insertion and six withdrawals per minute, the speed of travel of the plug being approximately 150 mm/s the period during which the plug is inserted and withdrawn shall be approximately equal. For the purpose of this test no lubrication is applied to the plugs or sockets either prior to or during the test.

After 5 000 insertions and withdrawals the standard rewirable plug used prior to the test, for each type of socket-outlet shall be reinserted and the earth resistance test repeated. After the test the earth resistance between the earthing plug pin and the earthing socket contact of the socket-outlets shall be in accordance with Clause **10.2.1b** of **SLS 734 Part 2**.

The socket outlet shall be examined and shall show no sign of damage that would impair further use. The plugs under test shall show no damage and shall conform to the dimensional requirements of this standard.

12.9.6 Plug pins and ISODs shall have adequate mechanical strength to ensure that they cannot be distorted by twisting.

12.9.6.1 Conformity shall be checked by inspection and by the following test.

The plug is clamped in a block as shown in Figure **23**. Each pin is Twisted about its longitudinal axis by applying a torque of $1 \text{ Nm} \pm 10 \text{ per cent}$, for 60^{+5}_0 s . The torque tube and its position on the plug pin shall be as shown in Figure **23**. After each pin has been separately twisted the plug shall fit the gauge shown in Figure **6**. The test shall then be repeated with each plug pin being twisted in the opposite direction to that of the first test. After this second test the plug shall fit the gauge shown in Figure **6**. In case the gauge is used in the manner as described in **12.2.1**.

12.10 The terminals of earthing and neutral plug pins shall be formed as one piece with or shall be permanently connected to the pin in such a way that efficient electrical connection is made that cannot work loose in use. This connection shall not be made by means of a screw.

The contact for the fuse link connected to the line terminal or termination shall be formed in one piece with the fixed part of the terminal or termination, or be permanently connected to it in such a way that it cannot work loose in normal use, and the other contact for the fuse link shall be similarly connected to the corresponding plug pin. The connections shall not be made means of screws.

The line terminals or termination shall provide for effectively clamping and securing conductors connected to it so that efficient electrical connection is made with the fuse link.

12.10.1 Conformity shall be checked by inspection and the test described in **19.1.3** and **15**.

12.11 Plugs shall be so designed that when fully assembled the pins are adequately retained in position such that there is no likelihood of them becoming detached from the plug during normal use.

12.11.1 Conformity shall be checked by the following test.

After the tests described in **19** each pin is subjected for 60^{+5}_0 s to a pull of 100_{-2}^0 N in one smooth and continuous motion in the direction of the major axis. The plug is mounted using

the steel plate shown in Figure 8. The apparatus is placed within an oven and the pull is applied at least 1h after the plug body has attained the test temperature of $70\text{ }^{\circ}\text{C} \pm 5\text{ }^{\circ}\text{C}$ while maintained at this temperature.

After the test the plug pin shall fit the gauge shown in Figure 6 when used in the manner as described in 12.2.1.

12.12 The degree of flexibility of mounting of the plug pins or the angular movement of the pins in the base shall be not greater than $3^{\circ} 30'$ in the directions shown in Figure 9 from an axis which is perpendicular to the plug engagement surface when the pins are subjected to a force as shown in Figure 9.

12.12.1 Conformity shall be checked by inspection and in case of doubt by the following test.

NOTE: *Plugs may be checked using an apparatus similar to that shown in Figure 9. (Other methods of measuring the $3^{\circ}30'$ deflection may be used.)*

The plug is clamped in the mounting block by means of any two of the plug pins in such a manner as to ensure that the engagement surface of the plug, from which the plug pins project, is supported and in contact with the corresponding flat surface of the mounting block. The back of the plug is not supported and does not come into contact with the fixture. The axis of the clamped pins is horizontal.

The unclamped pin shall be tested for declination from the horizontal by applying force of $4.4_{-0.2}^{+0}\text{ N}$, $25_{-0.5}^{+0}\text{ mm}$ from the engagement surface of the plug and parallel with it in the four directions shown in Figure 9. The test shall be repeated in turn on the other two pins of the plug.

During each test the delineation from the horizontal measured on the scale shall not exceed $3^{\circ} 30'$. After all tests have been completed the plugs shall fit the gauge shown in Figure 6 when used in the manner as described in 12.2.1.

12.13 Suitable means shall be provided for withdrawing the plug without subjecting the flexible cable to stress.

12.13.1 Conformity shall be checked by inspection.

12.14 Non-rewirable plugs shall be fitted with flexible cables in accordance with 18.4

12.14.1 Conformity shall be checked by inspection.

12.15 Conductive component parts of plugs shall be so located and separated that, in normal use, they cannot be displaced so as to affect adversely the safety or proper operation of the plug.

12.15.1 Conformity shall be checked by inspection and manual manipulations.

12.16 Line and neutral plug pins shall be fitted with insulation sleeves. The dimensions of the pin and sleeve shall fall within those given in Figure 4. Sleeves shall not be fitted to any earthing plug pin.

12.16.1 Conformity shall be checked by inspection, and by measurement for pin and sleeve and use of the gauge shown in Figure 6 as described in 12.2.1 for socket-outlet compatibility.

12.17 Plug pin sleeves shall have adequate electric strength, resistance to abrasion and resistance to deformation due to overheating of pins.

12.17.1 Conformity shall be checked by the test given in **12.17.2** to **12.17.4**.

12.17.2 A 50 Hz voltage of substantially sinusoidal waveform is applied between each L and N pin and a thin metal strip of between 5.5 mm and 6 mm with wrapped around the base of the plug pin sleeve adjacent to the base of the plug. Initially not more than 500 V is applied, the voltage then being raised to $1250 \text{ V} \pm 30 \text{ V}$ which is maintained for 60^{+5}_0 s.

During the test no breakdown or flashover shall occur.

12.17.3 The test apparatus for resistance to abrasion (see Figure **10**) comprises a horizontally disposed beam pivoted about its centre point. A short length of steel wire 1 mm ± 0.02 mm in diameter and bent into a 'U' shape, the base of the 'U' being straight, with no surface defects, is rigidly attached at both ends to one end of the beam so that the straight part of the wire projects below the beam and is parallel to the axis of the beam pivot.

The plug is held in a suitable clamp as shown in Figure **10** in such a position that the straight part of the steel wire rests upon the plug pin at right angles to it and the plug pin slopes downward at an angle between 5° and 10° to the horizontal. The beam is loaded so that the wire exerts a force of $4.0_{.1}^0$ N on the pin.

The plug is moved backwards and forwards in a horizontal direction in the plane of the axis of the beam so that the wire rubs along the pin. The length of the pin abrasion is approximately 9 mm, of which approximately 7 mm is over the insulating sleeve.

The plug is moved 10 000 times in each direction (20 000 movements) at a rate of 25 to 30 movements per minute.

The test shall be made on one pin of each plug.

After the test the sleeve shall show no damage which might impair the further use of the plug. The sleeve shall not have been penetrated or creased and shall satisfy the tests described in **12.17.2**, any abraded brass contamination on the sleeve having been removed.

12.17.4 A set of three sample pins are tested by means of the apparatus shown in Figure **10** which has a blade $0.70^{+0.05}_0$ mm wide and a radius of $3 \text{ mm} \pm 0.1 \text{ mm}$. the test is made on one pin of each plug not used for the test described in **12.17.3**.

A sample is positioned as shown in Figure **11** and the apparatus is loaded so that the blade exerts a force of $2.5^{0}_{-0.01}$ N on the sample the apparatus, complete with sample, is then placed in a heating cabinet at 200^{0}_{-8} °C for a period of 120^{0}_{-5} min, after which the sample is removed and immediately cooled by immersion in water at approximately room temperature.

The thickness of the insulation remaining at the point of impression is measured and shall not have been reduced by more than 50 per cent.

12.18 Switches shall be so constructed that undue arcing cannot occur when the switch is operated slowly. The switch in any switched fused plug shall disconnect at least the supply to the line terminals.

Double pole switches shall make or break each pole with one movement of the actuator.

12.18.1 Conformity shall be checked by inspection and by the following test.

Following the test described in **16**, the circuit is broken a further ten times, each time moving the actuating member by hand over a period of approximately 2 s in a manner such as to attempt to stop the moving contact in an intermediate position causing arcing the actuating member shall be released after approximately 2 s and any arcing shall cease.

12.18.2 The actuating member of a switch shall not remain at rest in the ‘off’ position whilst switch contacts remain closed. The actuating mechanism shall be so constructed that when operated the switch can remain only in a position giving adequate contact or adequate separation of contacts. For switched fused plugs that cannot be dismantled after assemble an additional new set of three samples prepared with the contacts closed is supplied by the manufacturer for this test.

12.18.2.1. Conformity shall be checked by inspection and the test of **12.18.3**.

12.18.3 The necessary force F to switch off shall first be measured and the force shall be applied to the extremity of the actuating member.

With the actuating member of the switch in the closed position, the fixed and moving contact of each pole shall be mechanically fixed together to provide the most onerous condition.

The method for fixing the contacts shall not unduly affect the test result. The test sample may be dismantled where necessary in preparation for this test and the test sample and components shall not be damaged during this preparation.

The actuating member shall be subjected to a test force as defined in Table 7. This force shall be applied in one smooth and continuous motion to the extreme point of the actuating member in the most favorable direction to open the contacts for a period of 10 s.

If locking means are designed to lock the actuating members in opened position, it shall not be possible to lock the actuating members in opened position, it shall not be possible to lock the actuating members in this position while the force is applied.

After the test and when the test force is no longer applied, the actuating member shall not remain at rest in the “off” position.

TABLE 7 - Actuator test force

Type of actuator	Test force	Minimum test force N	Maximum test force N
(1)	(2)	(3)	(4)
Switch actuator	3F	50	150

F is the normal operating force in new condition. The test force shall be $3F$ with the stated minimum and maximum values applied.

NOTE: *The use of grease and the like is not considered to be a mechanical fixing means.*

13 RESISTANCE TO AGEING AND TO HUMIDITY

13.1 Resistance to ageing

Plugs shall be resistant to ageing.

13.1.1 Conformity shall be checked by the following test.

Plug are subjected to a test in a heating cabinet with an atmosphere having the composition and pressure of the ambient air and ventilated by natural circulation

The temperature of the cabinet is kept at $70\text{ °C} \pm 5\text{ °C}$.

The samples are kept in the cabinet for $168\text{ }^{+2}_0\text{ h}$.

NOTES:

- 1) *The use of an electrically heated cabinet is recommended.*
- 2) *Natural circulation may be provided by holes in the walls of the cabinet.*

After the treatment, the samples are removed from the cabinet and kept at room temperature and relative humidity for 1 h” following which they are examined and shall show no damage which:

- would lead to non- conformity with this standard;
- would impair safety ; or
- would prevent further use.

13.2 Resistance to humidity

Plug shall be resistant to humid conditions which may occur in normal use.

13.2.1 Conformity shall be checked by the humidity treatment described below followed within 20 min by the measurement of the insulation resistance and by the electric strength test specified in **14**.

Rewirable plugs are fitted with $1000\text{ mm} \pm 50\text{ mm}$ of 3- core 1.5 mm^2 PVC flexible cable as given in **SLS 1504 Part 2-11**. Non-rewirable plugs are tested with $1\ 000\text{ mm} \pm 50\text{ mm}$ of the flexible cable with which they are supplied measured from the centre of the earth pin.

To suit the ambient conditions at the time of test, a convenient temperature, T (in °C), between 20 °C and 30 °C , is chosen as a reference temperature. The sample is brought to a temperature of between T and $T + 4\text{ °C}$ and is then placed in a humidity cabinet containing air with a relative humidity maintained between 85 per cent and 95 per cent. The temperature of the air where the samples are placed shall be kept within $\pm 2\text{ °C}$ of the chose value T .

The sample shall be kept in the cabinet for 48^{+1}_0 h.

NOTES:

1) *In most cases samples may be brought to the chosen reference temperature by keeping them at this temperature for at least 4 h before the humidity treatment.*

2) *A relative humidity of between 85 per cent and 95 per cent can be obtained by placing in the humidity cabinet a saturated solution of potassium nitrate (KNO_2) or sodium sulfate ($Na SO_4$) in water having a sufficiently large contact surface with the air.*

In order to achieve the specified condition within the cabinet it is necessary to ensure constant circulation of the air within the cabinet and in general to use a cabinet which is thermally insulated.

The tests described in **14** shall be made in the humidity cabinet or immediately after removal of the sample from the cabinet in a room where the specified temperature is maintained. inspection shall not reveal any damage to the sample which would impair its use or safety within the requirements of this part of **SLS 734**.

14 INSULATION RESISTANCE AND ELECTRIC STRENGTH

14.1 The insulation resistance and electric strength of plugs shall be adequate.

14.1.1 Conformity shall be checked by the tests described in **14.1.2** and **14.1.3**.

14.1.2 The insulation resistance is measured using a d.c.voltage of 500^{+250}_0 V, the measurement being made for 60^{+5}_0 s after application of the voltage. The insulation resistance is measured consecutively between:

- a) line and neutral terminals/terminations;
- b) Line and neutral terminals / terminations connected together and:
 - i) a metal foil in contact with the entire accessible external surface;
 - ii) the earthing terminals / termination;
 - iii) any metal part of a cable anchorage;
- c) each switched pole terminal of a switched plug and corresponding plug pin, with the switch contacts open.

The insulation resistance shall be not less than the following:

- i) 5 M Ω between parts of opposite polarity;
- ii) 5 M Ω between parts of opposite polarity connected together, and other parts, including earthed metal, intended to be insulated from them;
- iii) 2 M Ω across switch contacts with the switch open, where applicable.

One pole of neon indicators and the like shall be disconnected before marking this test.

Where terminals/terminations are not directly accessible, e.g. in non-rewirable plugs, these tests shall be made using accessible parts e.g pink known to be connected to the terminations.

14.1.3 A 50 Hz voltage of substantially sinusoidal waveform is applied as described in **14.1.2** initially, not more than 1 000 V is applied, the voltage then being raised to 2 000 V ± 60 V. The high voltage source used shall be such that when the output is adjusted to 2 000 V ± 60 V 60^{+5}_0 s and is then short-circuited, the output current is not less than 200 mA. Any over current protection shall not operate at a current less than 100 mA.

During the test no flashover or breakdown shall occur.

Glow discharges without drop in voltage shall be ignored.

One pole of neon indicators and the like shall be disconnected before marking this test.

14.2 Non-rewirable plugs shall withstand a high voltage, for which the test voltage shall be alternating (50 Hz to 60Hz), applied between all current-carrying parts connected together and a conduction electrode in contact with the entire outer accessible surface, omitting the engagement face. This test shall be carried out at 6 000 V ± 100 V for a period between 3 s and 5 s.

During the test no breakdown or flashover shall occur.

Glow discharges without drop in voltage shall be ignored.

15 TEMPERATURE RISE

15.1 Plugs and their surroundings shall not attain excessive temperatures in normal use.

15.1.1 Conformity shall be checked by the following tests.

The tests shall be carried out at rated voltage + 10 per cent, -20 per cent.

For these tests, where conductors are connected to terminals the terminal screws shall be tightened with a torque equal to two thirds of the values given in Table 6.

For rewirable plugs with clamp type (screwless) terminals the connection of the conductors shall be made in accordance with the manufacturer's instructions.

During the tests temperature rises are measured where overheating might result in a hazard and the values measured shall not exceed the values given in Table 8. Additionally the temperature rises of the line and neutral plug pins are measured by means of thermocouples using the apparatus shown in Figure 13 and Figure 14. Temperature rises are determined by means of fine wire thermocouples so chosen and positioned that they have minimum effect on the temperature of the part under of test. The thermocouples are attached by means of a mixture of equal parts of resin adhesive and zinc oxide, by soldering or by other equally effective means.

NOTE: *If soldering is used it is essential that care is taken to ensure that the heat from the soldering process does not affect the performance of the plug and that no electrical connections are bridged by solder.*

If, in order to fix thermocouples, a non-rewirable plug is dissected to given access to the appropriate positions, the removed parts shall be replaced and if necessary shall be cemented in place so that no additional air spaces are created.

15.1.2 Rewirable plugs are tested with 1000 mm \pm 50 mm of 1.5 mm² 3 - core PVC insulated flexible cable as given in **SLS 1504-2-11**, non-rewirable plugs are tested with 1000 mm \pm 50 mm (measured from the Centre of the earth pin) of the flexible cable supplied at an appropriate test current as given in Table 2.

The plug is fitted with a calibrated link, constructed and calibrated in accordance with Annex A and is mounted in a flat insulating plate as shown in Figure 13 and Figure 14. The supply conductors are attached to the line and neutral pins of the plug by means of clamps which also serve to retain the plug in position. The clamp screws are tightened to a torque of between 0.8 Nm and 1.2 Nm. The assembly is mounted by means of screw in a standard steel flush – mounted socket outlet box as shown in Figure 1 of **SLS 1310**, having a nominal internal depth of 35 mm which is mounted in a test cabinet as shown in Figure 13.

The incoming cable and outgoing flexible cable shall enter the test cabinet through holes in the top surface which shall then be sealed to prevent circulation of air the length of cable and flexible cable within the Figure 13 and Figure 14 enclosure shall be of maximum length of 600 mm and 850 mm respectively. Care shall be taken to position the cable and flexible cable away from the reference temperature measuring point so not to influence the derivation of plug temperature rise values.

The incoming cable shall be a 2.5 mm² PVC insulated and sheathed cable, as given in Table 4 of **SLS 733** and shall enter the socket-outlet mounting box through the standard knockout provided. This shall be fitted with a suitable rubber grommet, the point of entry being sealed to prevent the circulation of air. The length of cable within the socket-outlet box shall be 150 mm \pm mm and the outer sheath and the circuit protective conductor shall be removed to within 20 mm of the point of entry. The test cabinet (see Figure 13, is placed in an environment having an ambient temperature of 20 °C \pm 5 °C. The test current is specified in Table 2 shall be passed through the plug and through a load connected to the flexible cable for a minimum continuous period of 4 h or longer until stability is reached with a maximum duration of 8 h, stability being taken as less than 1 K rise within 1 h.

The temperature rise is calculated by deducting the reference point temperature from the measurement point temperature record (see Figure 13 and Figure 14 respectively).

TABLE 8 - Permitted temperature rises

Measurement point	Temperature rise K
Line pin spacer (see Figure. 13 and 14)	37
Neutral pin spacer (see Figure. 13 and 14)	37
Terminals or terminations	52
Accessible external surface	52

NOTE: *The recording of a measured value up to and including the specified maximum permissible limit for temperature rise is considered to conform to the requirements of the standard on condition that the uncertainty of measurement at not less than 95 per cent confidence level does not exceed \pm 2 °C.*

16 BREAKING CAPACITY OF SWITCHES INCORPORATED IN FUSED PLUGS

16.1 The breaking capacity of switches incorporated in plug shall be adequate.

16.1.1 Conformity shall be checked by the following tests. The switch shall make and break a current of $1.25 \times$ rated current ± 0.4 A (i.e. $1.25 \times 13\text{A} \pm 0.4$ A) in a substantially non-inductive a.c circuit at $275 \text{ V} \pm 5 \text{ V}$, ten times in succession at interval of approximately 30 s. After the test the plug shall be capable to passing the subsequent tests detailed in table 1 for the appropriate test sample.

17 NORMAL OPERATION OF SWITCHES

17.1 Switches incorporated in plugs shall withstand, without excessive wear or other harmful effects, the electrical and mechanical stresses occurring in normal use.

17.1.1 Conformity shall be checked by the following tests. The voltage drop across each switched pole, measured at point immediately adjacent to the switch, shall not exceed 60 mV at rated current. The switch shall then make and break a current of $13 \text{ A} \pm 0.4 \text{ A}$ at $250 \text{ V} \pm 10 \text{ V}$, 15 000 times (30 000 movements) in a substantially non-inductive a.c. circuit at a rate of approximately six complete cycles per minute at regular intervals. The periods during which the switch is “on” and “off” shall be approximately equal. The means for operating the switch shall be such as to move the actuating member at a speed of approximately 300 mm/s both in making and breaking the circuit and shall be so positioned that the normal action of the mechanism is not interfered with in any way.

At the end of the test the switch shall be capable to making and breaking the rated current of $13\text{A} \pm 0.4 \text{ A}$ at $250 \text{ V} \pm 10\text{V}$ and the voltage drop across each switched pole measured as above shall not exceed 75 mV.

The switch shall also pass the tests given in **14**, the test voltage being reduced by 25 per cent.

18 CONNECTION OF FLEXIBLE CABLE AND CABLE ANCHORAGE

18.1 The entry of the flexible cable shall be between the current-carrying pins at the side of the plug opposite the earth pin (see Figure 15).

Provision shall be made for the entry and effective clamping without bending of 2-core and 3- core flexible cable for rewirable plugs as given in **SLS 1504-2-21** and **SLS 1504-2-11**, having nominal conductor cross-sectional areas not exceeding 1.5 mm^2 .

For non- rewirable plugs provision shall be made for the entry and adequate retention of the flexible cable with which the plugs is supplied, once assembled it shall not be possible in normal use to affect the integrity of the cable anchorage.

NOTE: *Flexible cable with a mean overall dimension less than those given in SLS 1504-2-21 (such as decorative light cords) are permitted, provided a suitable retention aid is fitted to the flexible cable or cable anchorage so that it conforms to this standard.*

The cable anchorage shall contain the sheath. Cable anchorage shall either be of insulating material or if of metal shall be provided with an insulating lining fixed to the metal parts. Methods such as tying the flexible cable into a knot or tying the ends with string or the like shall not be used.

18.1.1 Conformity shall be checked by inspection and by the following tests.

- a) Rewirable plugs are fitted with a 2- core 0.5 mm² flexible cable as given in **SLS 1504-2-11**. The conductors are introduced into the terminals and the terminal screws tightened to one third of the appropriate torque values listed in Table 6. The cable anchorage is used in the normal way the clamping screws if any being tightened to a torque of two thirds of that given in Table 6. The assembly is then left untouched for a minimum of 24 h.

After this preparation it shall not be possible to push the flexible cable into the plug to such an extent as to impair safety or so that the cable anchorage is loosened.

The flexible cable is then subjected 25 times to the pull given in Table 2. The pulls are applied in one smooth and continuous motion in the most unfavorable position momentarily. Immediately afterwards the flexible cable is subjected for 60⁺⁵₀ s to the appropriate torque shown in Table 2, at a minimum starting distance of 150 mm from the flexible cable entry measured along the length of the cable.

NOTE: *It is not intended that the dimension of 150 mm is maintained during the application of the test torque.*

These tests are then repeated but with the plug fitted with a 3- core flexible cable having a nominal conductor cross-sectional area of 1.5 mm² as given in **SLS 1504-2-11**.

- b) For non-rewirable plugs the test is carried out with the flexible cable with which it is supplied, using the appropriate load and torque as given in Table 2. The conductors of the flexible cable are severed at the point of termination prior to the test. In the case of two single core cable the load and torque shall be shared equally between the two cables.

During this test the insulation of the flexible cable shall not be damaged.

A voltage of 3750 V ±75 V is applied for 60⁺⁵₀ s between the conductors. Breakdown or flashover is considered to indicate damage to the flexible cable.

- c) After the test given in a) and b) the flexible cable shall not have been displaced by more than 2 mm.

For the measurement of longitudinal displacement a mark is made on the flexible cable whilst it is subjected to the load given in Table 2 at a point adjacent to the anchorage in the case of rewirable plugs, or as close as practicable to the cable anchorage in the case of non-rewirable plugs, before starting the tests. After the test the displacement of the mark on the flexible cable in relation to the cable anchorage is measured whilst the flexible cable is again subjected to the load given in Table 2.

18.2 Cable anchorages in rewirable plugs shall anchor the flexible cable securely to the plug. The design shall ensure the following:

- a) the cable anchorage cannot be released from the outside without the use of a tool;
- b) it shall not be possible to touch cable anchorage screws, if any with test probe B of **IEC 61032** when the plug is energized;
- c) the flexible cable is not clamped by a metal part bearing directly on the flexible cable;
- d) at least one part of the anchorage is securely fixed to the plug;
- e) clamping the flexible cable does not require the use of a special purpose tool;
- f) tightening the cable anchorage screws if any to the torque prescribed in Table 6 does not distort the engagement face of the plug to such an extent that conformity with **12.2** is affected;
- g) the cover may be correctly fitted without damage when the plug is wired with the largest specified flexible cable and all screws are tightened to the torque specified in Table 6.

18.2.1 Conformity shall be checked by inspection and test.

18.3 Screw which are used when clamping the flexible cable shall not serve to fix any other components unless either the plug is rendered manifestly incomplete if the component is omitted or is replaced in an incorrect position: or the component intended to be fixed cannot be removed without further use of a tool.

18.3.1 Conformity shall be checked by inspection

18.4 Non- rewirable plugs shall be fitted with flexible cables conforming to **SLS 1504-2-11**, **SLS 1504-2-12**, **SLS 1504-2-21**, **SLS 1504-2-71** or with flexible cable conforming to the requirements of the specification appropriate to the equipment to which they may be fitted. Connections shall be as given in Table 9.

18.4.1 Conformity shall be checked by inspection and a continuity test.

18.5 Non-rewirable plugs shall be so designed that the flexible cable is not subjected to excessive bending where it enters the plug.

18.5.1 Conformity shall be checked by the following test using an apparatus similar to that shown in Figure 15. The plug is fixed to the oscillating member of the apparatus so that when this is vertical the axis of the flexible cable at the point of entry is vertical and passes through the axis of oscillation.

Samples with flat flexible cables are mounted so that the major axis of the section is parallel to the axis of oscillation.

The flexible cable is loaded with a weight as given in Table 2. In the case of two single core cables the load shall be shared equally between the two cables.

The distance between the point of entry to the plug and the axis of oscillation is adjusted so that the weight makes the minimum lateral movement as the oscillating member moves. A current appropriate to the flexible cable fitted, as given in Table 2, is passed through the line and neutral

conductors, the voltage between them being 250 V \pm 10 V a.c. If an earthing conductor is incorporated in the flexible cable it shall be connected at one end to the neutral conductor.

The oscillating member is moved backwards and forwards through an angle of $45^\circ \pm 3^\circ$ on either side of the vertical, the number of flexings being 10 000 at a rate of 60_{-10}^0 flexings per minute.

After 5 000 flexing plugs with flexible cable of circular section are turned through $90^\circ \pm 5^\circ$ about the flexible cable entry centerline.

NOTE: A flexing is one movement through 90° either backwards or forwards.

During the test there shall be no interruption of the current passing through the conductors and no short-circuit between them.

After the test the sample shall show no damage except that breakage of no more than 10 per cent of the total number of conductor strands in any core is ignored provided they have not pierced the insulation.

18.6 The flexible cable entry to rewirable plugs shall be so shaped as to prevent damage to the flexible cable.

18.6.1 Conformity shall be checked by inspection.

TABLE 9 - Connection of flexible cables

Termination	Conductor insulation colour		
	3- core	2- core colour coded	Flexible cables as given in SLS 1504-2-71
(1)	(2)	(3)	(4)
Earth	Green-and-yellow	No connection	No connection
Line	Brown	Brown	As supplied
Neutral	Blue	Blue	As supplied

19 MECHANICAL STRENGTH

19.1 Plug shall have adequate mechanical strength and be so constructed as to withstand such handling as may be expected in normal use.

19.1.1 Conformity shall be checked by the tests given in **19.1.2** and **19.1.3**.

19.1.2 A solid link of stainless steel as shown in Figure 16 is inserted and withdrawn from the fuse clips of the plug 20 times in succession in a normal manner, at a rate not exceeding ten per minute. A standard fuse link conforming to **SLS 1533** is then fitted and the appropriate mechanical strength test completed.

19.1.3 Rewirable plugs are fitted with 3- core PVC 1.5 mm^2 flexible cable as given in **SLS 1504-2-11**, the terminals and cover screws being tightened with the torque given in Table 6. Non- rewirable plugs are tested as delivered.

Rewirable plugs with clamp type (screwless) terminals are fitted with 3-core PVC 1.5 mm² flexible cable as given in **SLS 1504-2-11**. The connection of the conductors shall be made in accordance with the manufacturer's instructions.

The flexible cable attached to plugs are cut to a length of 150 mm \pm 5 mm measured from the nearest edge of the earthing pin, precoiled flexible cable being extended before measurement.

Plugs are tested in the tumbling barrel shown in Figure **17**. The barrel is turned at a rate of approximately 5 r/min (approximately ten drops per minute).

Only one plug is tested at a time. The number of drops is as follows:

- a) rewirable plugs : 1 000;
- b) non- rewirable plugs : 2 500;
- c) plugs marked letter "A" : 5 000;
- d) plugs marked letter "EV" : 5 000.

After the test the plug shall show no external damage which might affect safety and no components shall have become detached. The earthing pin terminal screw if any shall remain tight to a torque not less than 70 per cent of the original tightening torque and current-carrying joints shall not have become loose and shall make satisfactory contact. The sample shall then be checked by inspection, and shall conform to the appropriate test described in **15** and the gauge in accordance with Figure **6** when used in a manner as described in **12.2.1** but with a force not exceeding 20 N.

For the repeat test given in **15**, the attached flexible cable is retained without disturbing the terminal connections, but the conductor insulation and sheath are removed only as far as is necessary for the attachment of a 1 000 mm \pm 50 mm length of flexible cable of the same type as that already attached to the plug the connection being made by means of a connector having a current rating appropriate to that flexible cable.

20 SCREWS, CURRENT- CARRYING PARTS AND CONNECTIONS

20.1 Screwed connections electrical and otherwise, shall withstand the mechanical stresses occurring in normal use. screws directly transmitting electrical contact pressure shall screw into metal. Screws shall not be of metal which is soft and liable to creep.

Screws shall not be of insulating material if their replacement by a metal screw would affect the safety or performance requirements of the plug.

Contact pressure in electrical connections within the plug and between the plug and the cable or flexible cable connected to it shall not be transmitted through insulating material other than ceramic, pure mica or other material with characteristics not less suitable, unless there is sufficient resiliency in the metallic parts to compensate for any possible shrinkage or yielding of the insulating material.

NOTE: *The suitability of other materials is considered in respect of the stability of the dimensions under all conditions of normal use especially in view of shrinking ageing or cold flow of the insulating part.*

20.1.1 Conformity shall be checked by inspection and, for screws and nuts which are intended to be tightened during installation, or use, or during replacement of the fuse link by the following test.

The screw is tightened and loosened as follows:

- a) ten times for screw in engagement with a thread of insulating material, the screw being completely removed and replaced each time;
- b) five times for nuts and other screws.

When testing terminal screws and nuts a 1.5 mm² flexible conductor is placed in the terminal of plugs. The conductor is moved each time the screw is loosened. The test is made by means of suitable test screwdriver, applying a torque as given in Table 6 in one smooth and continuous motion, the shape of the blade of the test screwdriver shall suit the head of the screw being tested.

During the test no damage impairing the further use of the screwed connection shall occur.

For clamp type (screw less) terminals conformity shall be checked by inspection and the test given in 24.

20.2 Thread- cutting and/or thread forming screws shall not be used for the marking of current- carrying or earth continuity connections.

Screws which make a mechanical connection between different parts of the plug shall be locked against loosening, if the connection carries current.

Rivets used for current-carrying or earth continuity connections shall be locked against loosening if these connections are subject to torsion in normal use which is likely to loosen the connection.

20.2.1 Conformity shall be checked by inspection and by manual test.

NOTES:

- 1) *Spring washers and the like may provide satisfactory locking.*
- 2) *For rivets a non –circular shank or an appropriate notch may be sufficient.*

20.3 Current carrying parts (except for line and neutral plug pins) and earthing plug pins shall be of brass, copper, prosper–bronze or other metal at least equivalent with regard to its conductivity, resistance to abrasion and resistance to corrosion, except for screws, nuts, washers, clamping plates and similar parts of terminals, nor to parts of plugs used for earth continuity purposes.

20.3.1 Conformity shall be checked by inspection and by the relevant tests described in 10.1, 15 and 23.

21 RESISTANCE TO HEAT

21.1 Plugs shall be resistant to heat.

21.1.1 Conformity shall be checked by the test described in **21.1.2** or **21.1.3**.

21.1.2 Plug samples are kept for 60^{+5}_0 min in a heating cabinet maintained at $70\text{ °C} \pm 5\text{ °C}$. During the test they shall not undergo any change impairing their further use and sealing compound shall not flow to such an extent that live parts are exposed.

NOTE: *A slight displacement of the sealing compound should be disregarded.*

After the test the plug shall still satisfy the tests described in **9.2.1** and **14.1.3**.

21.1.3 Plug with external parts of resilient material e.g thermoplastics and rubber are subjected to a pressure test by means of an apparatus similar to that shown in Figure **18**, the test being made in a heating cabinet at a temperature of $70\text{ °C} \pm 5\text{ °C}$.

The plug is clamped between the jaws in such a way that these press against it in the area where it is gripped in normal use the centerline of the jaws coinciding as nearly as possible with the centre of this area.

The force applied through and including the effect of the jaws is 20.1^0 N.

After 60_0^{+5} min the jaws are removed and the plugs shall satisfy the test described in **14.1.2b)i)** and **14.1.3** and shall fit the gauge given in Figure **6** when used in a manner as described in **12.2.1**.

21.2 Parts of insulating material shall be sufficiently resistant to heat having particular regard for their location and function in the complete plug.

21.2.1 Conformity shall be checked as follows:

- a) parts of ceramic material are deemed to conform without testing;
- b) external parts of plugs tested according to **21.1.3**, are deemed to conform without further testing;
- c) all other parts of insulating material including ISOD if fitted shall be subjected to the ball pressure test in accordance with **IEC 60695-10-2**. The test is made in a heating cabinet maintained at a temperature of $75\text{ °C} \pm 5\text{ °C}$.

22 RESISTANCE TO ABNORMAL HEAT AND FIRE

22.1 General

Plugs shall be resistant to abnormal heat and fire.

22.1.1 Conformity shall be checked by the test described in **22.2**.

The tests shall not be made on parts of ceramic material or metal.

22.2 Glow-wire test

The test is performed according to **IEC 60695-2-11** and at the test temperature given in Table 10.

TABLE 10 - Application of glow-wire test

Part	Temperature of glow-wire °C
Part necessary to retain live parts in position including ISOD	750±10
Parts not necessary to retain live parts in position (although they may be in contact with live parts)	650±10

NOTE: *If the test specified is required to be made at more than one place on the same sample, it is essential that care is taken to ensure that any deterioration caused by previous test does not affect the result of the test to be made.*

Small parts (see **3.31**), parts of insignificant mass (see **3.30**), parts unlikely to be subjected to abnormal heat and parts whose failure to pass these tests would not materially affect the safety of the plug are not subjected to this glow-wire test.

The glow-wire test is applied to ensure that an electrically heated test wire under defined test conditions does not cause ignition of insulating parts or to ensure that a part of insulating material, which might be ignited by the heated test wire under defined condition, has a limited time to burn without spreading fire by flame or burning parts or droplets falling down from the tested part onto a pinewood board covered with tissue paper.

The test sample shall be either a complete plug or, if the test cannot be made on a complete plug, a suitable part may be cut from one for one for the purpose of the test.

The test shall be made on one sample.

In case of doubt, the test shall be repeated on two further samples.

The test shall be made applying the glow-wire once.

The sample shall be positioned during the test in the most unfavourable position of its intended use (with the surface tested in a vertical position).

The tip of the glow-wire shall be applied to the specified surface of the sample taking into account the conditions of intended use under which a heated or glowing element may come into contact with the sample.

The sample shall be regarded as having passed the glow-wire test if:

- a) There is no visible flame and no sustained glowing; or
- b) Flames and glowing of the sample extinguish within 30 s after the removal of the glow-wire.

There shall be no ignition of the tissue paper or scorching of the board.

23 RESISTANCE TO EXCESSIVE RESIDUAL STRESSES AND TO RUSTING

23.1 Press-formed or similar current carrying parts of copper alloy containing less than 80 per cent of copper shall be resistant to failure in use due to stress corrosion.

23.1.1 Conformity shall be checked as following test.

The sample is degreased in a suitable alkaline degreasing solution or organic solvent, then immersed in an aqueous solution of mercurous nitrate containing 10g of $\text{Hg}_2(\text{NO}_3)_2$ and 10 ml of HNO_3 (relative density 1.42) per liter of solution for 30 min \pm 1 min at a temperature of $20\text{ }^\circ\text{C} \pm 5\text{ }^\circ\text{C}$.

NOTE: *Attention is drawn to the fact that due precaution should be taken when using these liquids as they are toxic.*

After the treatment the sample is washed in running water, any excess mercury wiped off and the sample is immediately visually examined.

There shall be no cracks visible with normal or corrected vision without additional magnification.

23.2 Ferrous parts, the rusting of which might cause the plug to become unsafe, shall be adequately protected against rusting.

23.2.1 *Conformity shall be checked by the following test.*

The sample is degreased in a suitable alkaline degreasing solution or organic solvent, the parts are then immersed for 10 min \pm 0.5min in a 10 per cent solution of ammonium chloride in water at a temperature of $20\text{ }^\circ\text{C} \pm 5\text{ }^\circ\text{C}$.

Without drying but after shaking off any drops, the parts are placed for 10 min \pm 0.5 min in a box containing air saturated with moisture at a temperature of $20\text{ }^\circ\text{C} \pm 5\text{ }^\circ\text{C}$. After the parts have been dried for at least 10 min in a heating cabinet at a temperature of $100\text{ }^\circ\text{C} \pm 5\text{ }^\circ\text{C}$ their surfaces shall show no signs of rust.

NOTES:

1) *Traces of rust on sharp edges and any yellowish film removable by rubbing should be ignored.*

2) *For small helical springs and the like, and for parts exposed to abrasion, a layer of grease may provide sufficient protection against rusting. Such parts are only subjected to the test if there is doubt the effectiveness of the grease film and the test should then be made without previous removal of the grease.*

24 ELECTRICAL AND THERMAL STRESS OF CLAMP TYPE (SCREWLESS) TERMINALS

24.1 Clamp type (screwless) terminals shall pass the electrical and thermal stresses occurring in use.

24.1.1 Conformity shall be checked by the following tests.

The rewirable plug shall be wired and mounted for test in accordance with **15**. The ambient temperature condition specified in **5.1** shall apply. The plug shall be fitted with a calibrated link for the tests. A test current of 14 A 0.4 A shall be passed through the plug and flexible cable combination for a period of 60 min \pm 2 min, after which the plug and flexible cable combination shall be allowed to cool naturally for a period of 60 min \pm 2 min. The test cycle of 60 min “on” and 60 min “off” shall be repeated a further 199 times. During the test, the calibrated link is replaced during the “off” period of every 48th consecutive cycle from the commencement of the test by a new link having characteristics known to be within calibration limits. The link is then replaced without disturbing the terminals or conductor terminations in so far as this is possible.

At the conclusion of the final cycle and without disturbance, the plug shall be subjected to a temperature rise test in accordance with **15**. The measured temperature rise values shall not exceed those values given in Table **8**.

After the test inspection by normal or corrected vision, without additional magnification, shall show no change impairing further use, such as cracks, deformation, or the like.

25 OVERLOAD TESTS

25.1 Plug shall withstand overload currents, which could occur due to overload, without creating a risk of contact with live parts.

25.1.1. Conformity shall be checked by the following tests given in **25.1.2** to **25.1.4**. The test arrangement shall be as described in **15.1** except no thermocouples or pin spacers shall be used and the test can be conducted at any voltage between 12 V and 250 V.

NOTE: *Owing to the high temperatures which can be expected during these tests, laboratories are advised to use separate test cabinets for these tests.*

25.1.2 The plug shall be fitted with a fuse link conforming to **SLS 1533** with a rating as marked on the plug. The plug shall then be subjected to a test current of 1.6 times the rating of the fuse for 60 min or until the fuse operates (if less than 60 min) immediately afterwards, the checks specified in **25.1.4** shall be made.

25.1.3 The plug shall be fitted with a fuse link conforming to **SLS 1533** with a rating as marked on the plug. The plug shall then be subjected to a test current of 1.9 times the rating of the fuse for 30 min or until the fuse operates (if less than 30 min) immediately afterwards, the checks specified in **25.1.4** shall be made.

25.1.4 Each plug shall be checked for conformity with **9.1**, **12.6.1a)**, **12.6.1b)** and **12.11.1**, except that the tests shall be performed at ambient temperature. Deterioration which does not compromise access to live parts (e.g. discoloring, distortion) shall be deemed to be acceptable. Inspection shall not reveal any damage to the plug which would impair its safety within the requirements of this part of **SLS 734**.

26 CYCLIC LOADING TEST

26.1 Requirement

Plug classified as being suitable for electric vehicle charging shall withstand the associated electrical and mechanical stresses.

26.2 Testing

Conformity shall be checked by the following test.

The test arrangement shall be as described in **15.1**.

Rewirable plugs shall be fitted with 1 000 mm \pm 50 mm length 3-core PVC 1.5 mm² flexible cable as given in **SLS 1504-2-11** and the terminals shall be tightened with two third of the torque given in Table 6. Non-rewirable plugs shall be tested as delivered.

Rewirable plugs with clamp type (screwless) terminals shall be fitted with 1 000 mm \pm 50 mm length 3-core PVC 1.5 mm² flexible cable conforming to **SLS 1504-2-11**. The connection of the conductors shall be made in accordance with the manufacturer's instructions.

The test shall be carried out at rated voltage.

The plug shall be connected to a load of $13^{+0.4}_0$ A.

The test shall be connected for 28 continuous cycles, each cycle consisting of 8 h "on", 1 h "off", 8 h "on" and 7 h "off".

The plug shall then be checked by inspection and shall be in accordance with the appropriate requirements described in **15**, and the inspection requirements of **12.2.1** using the Figure 6 gauge with a force not exceeding 20 N.

For the repeat test given in **15**, the attached flexible cable is retained without disturbing the terminal connections.

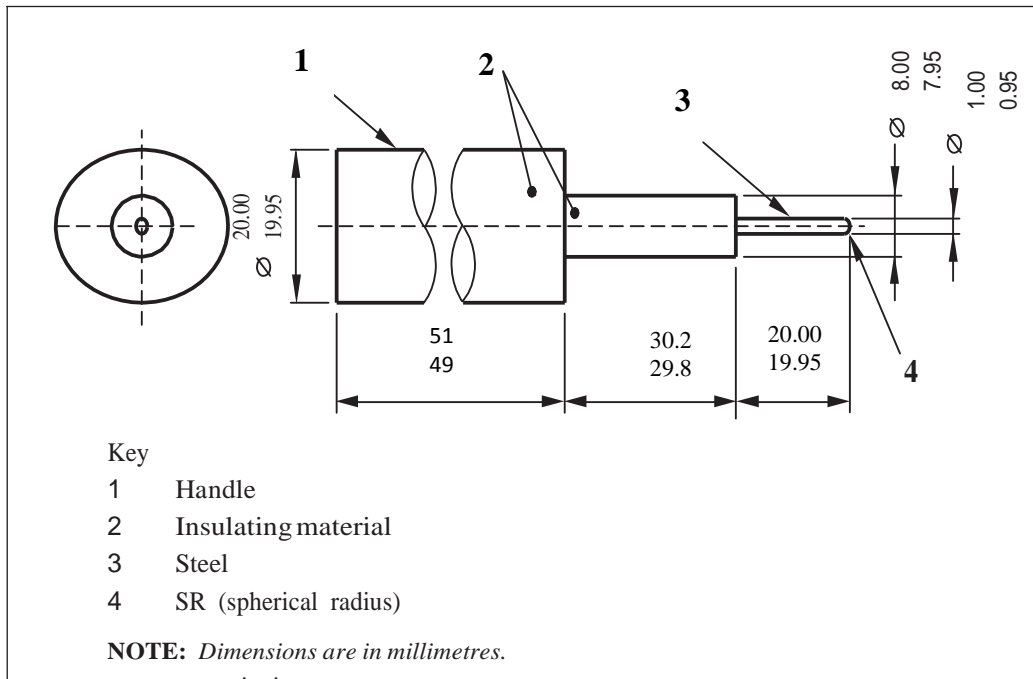

FIGURE 1 - Test pin (see 9)

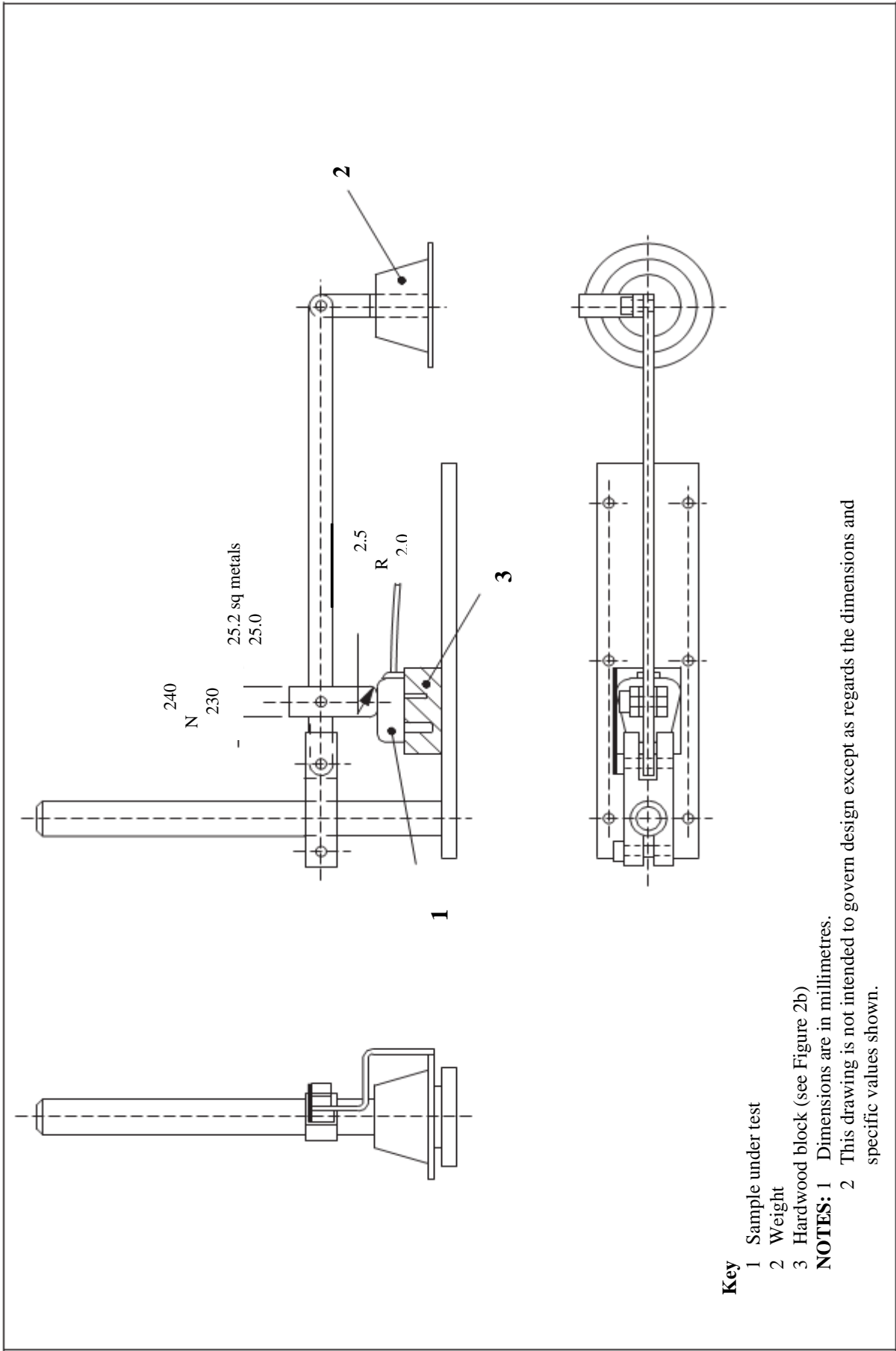

FIGURE 2 - Apparatus for mechanical strength test on resilient covers (see 9)

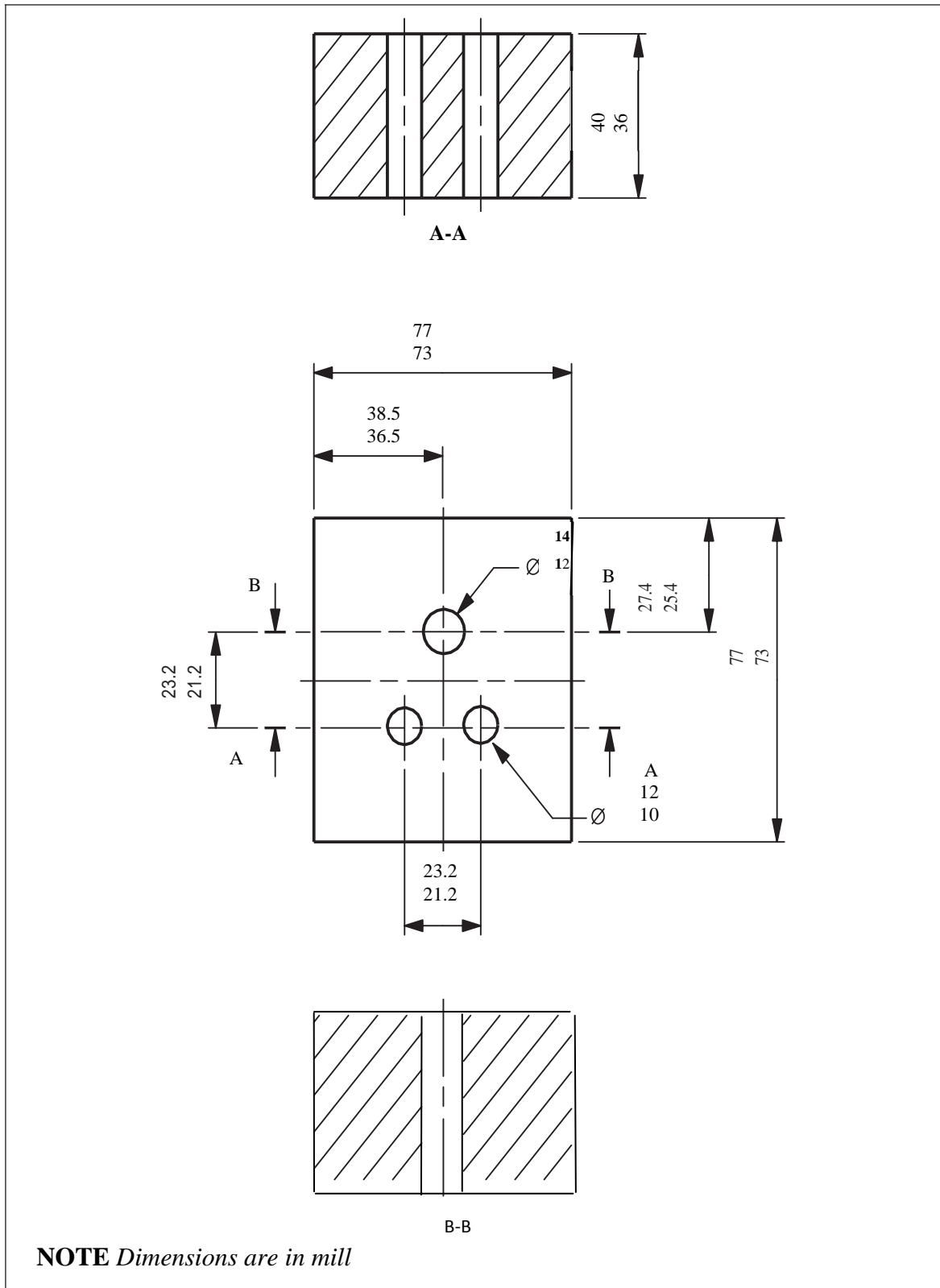

FIGURE 3 - Hardwood block for Figure 2

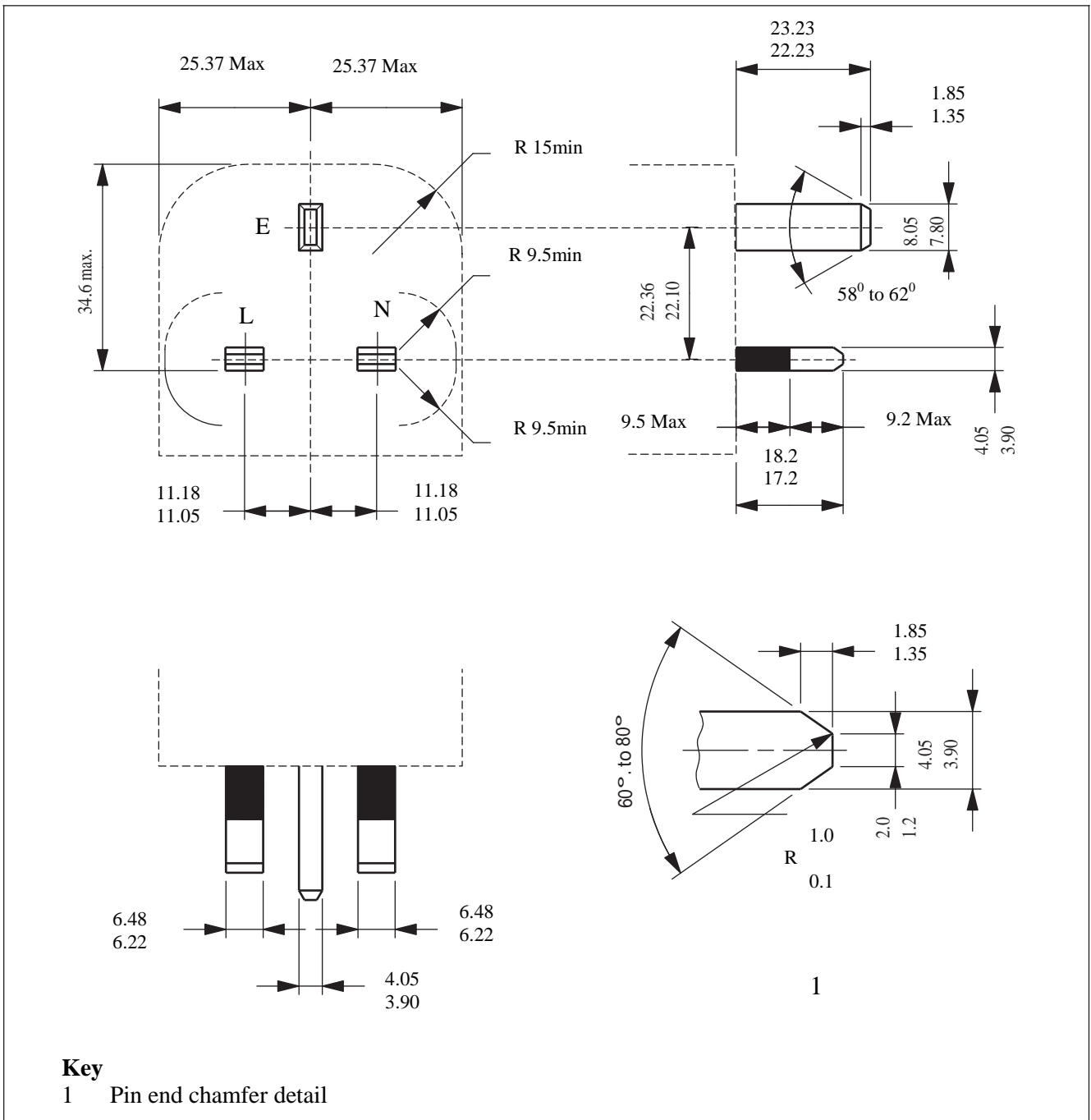

FIGURE 4 - Dimensions and disposition of pins (see 12) (Continued)

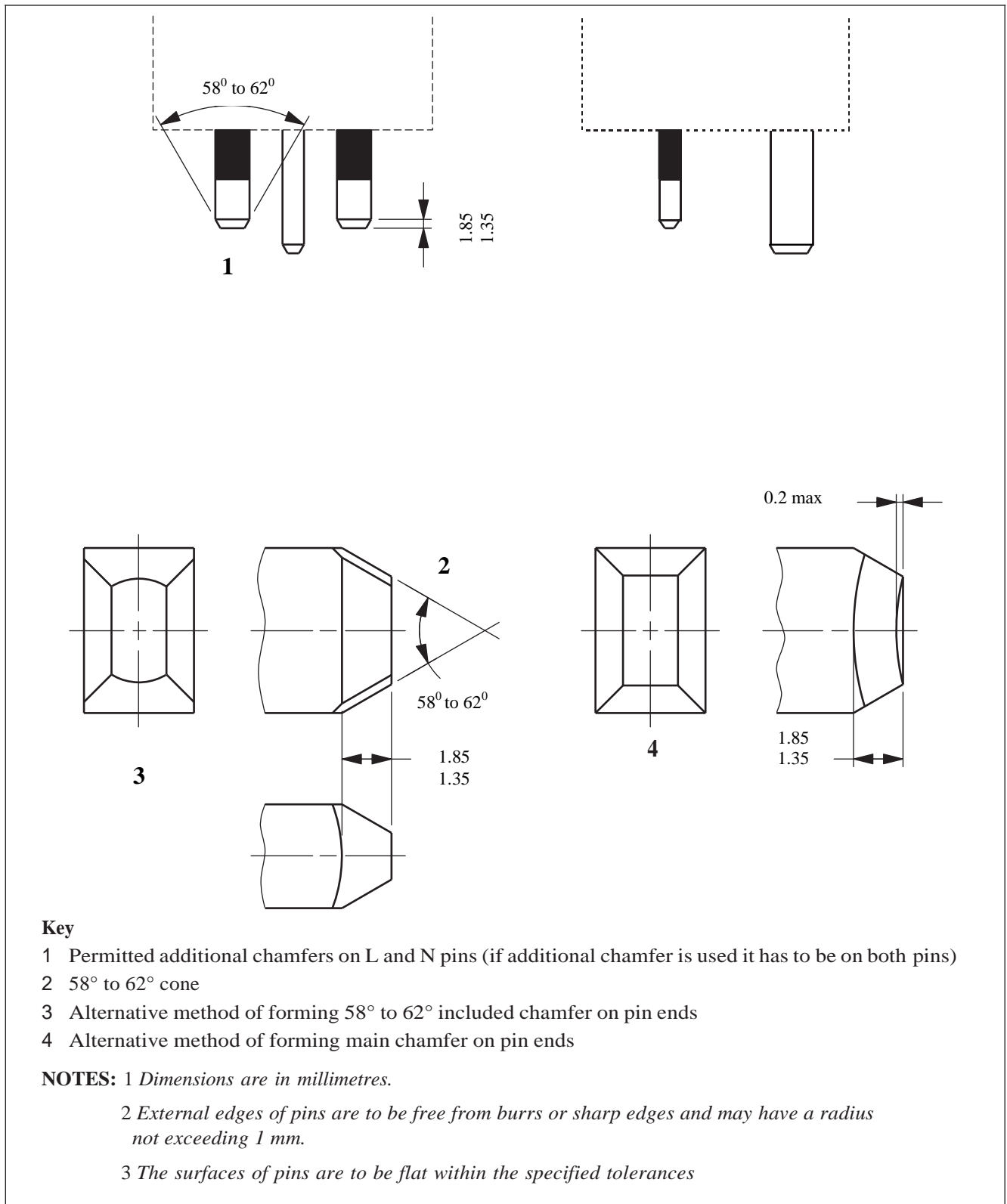
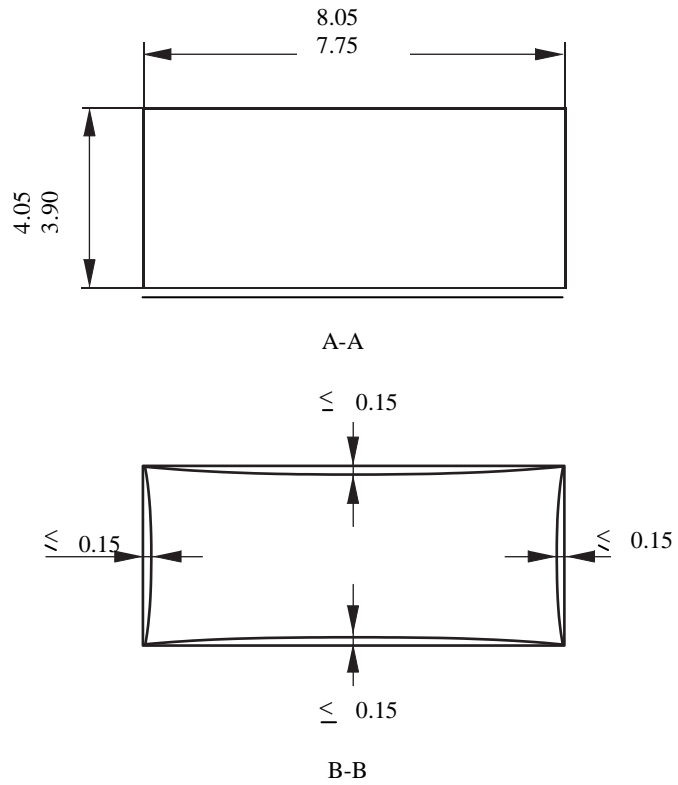
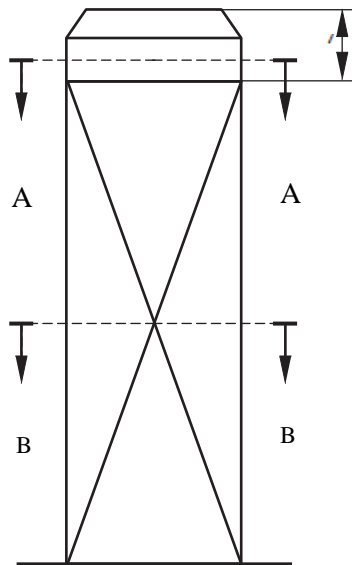
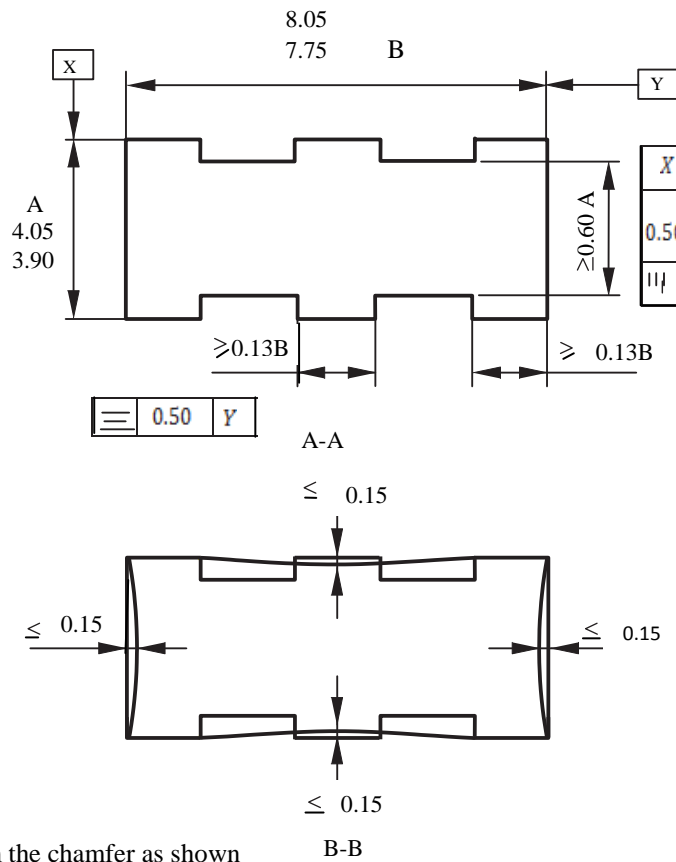
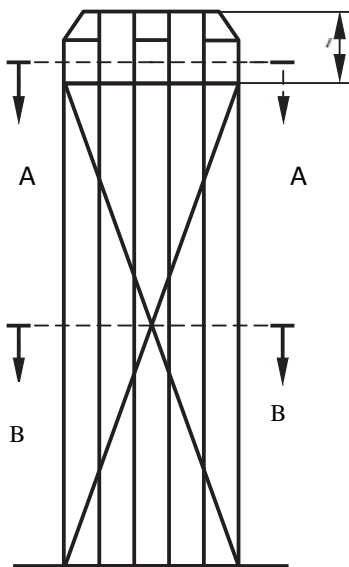

FIGURE 4 - Dimensions and disposition of pins (see 12) (Concluded)

Solid ISOD



Castellated ISOD



NOTE:

- 1 Dimensions are in millimetres
- 2 Section A-A to be measured away from the chamfer as shown

FIGURE 5 – Concave shrinkage allowances for ISODs

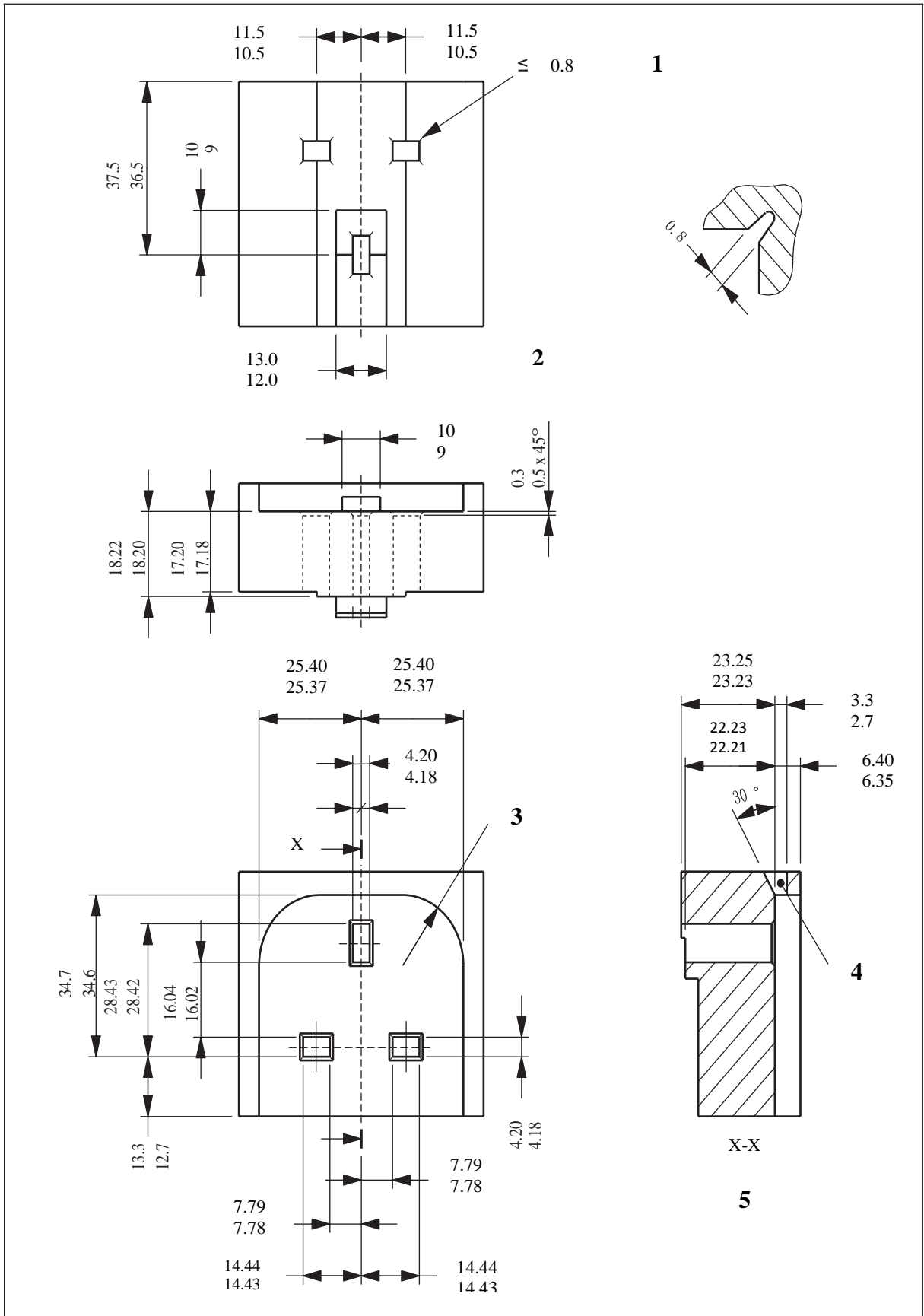

FIGURE 6 - Gauge for plug pins (see 12, 19, and 21) (Continued)

Key

- 1 Corners may be relieved up to width of 0.8 as shown
- 2 Chamfer all round
- 3 Radius =15.088 TP (true profile) with a tolerance zone 0.100 wide, ± 0.050 from the TP; the form of this contour is to blend smoothly with the sides
- 4 Slot optional
- 5 Gauge may be fabricated in several component parts, providing assembly is within dimensions shown

NOTE : *Dimensions are in millimeter.*

FIGURE 6 - Gauge for plug pins (see 12, 19, and 21) (Concluded)

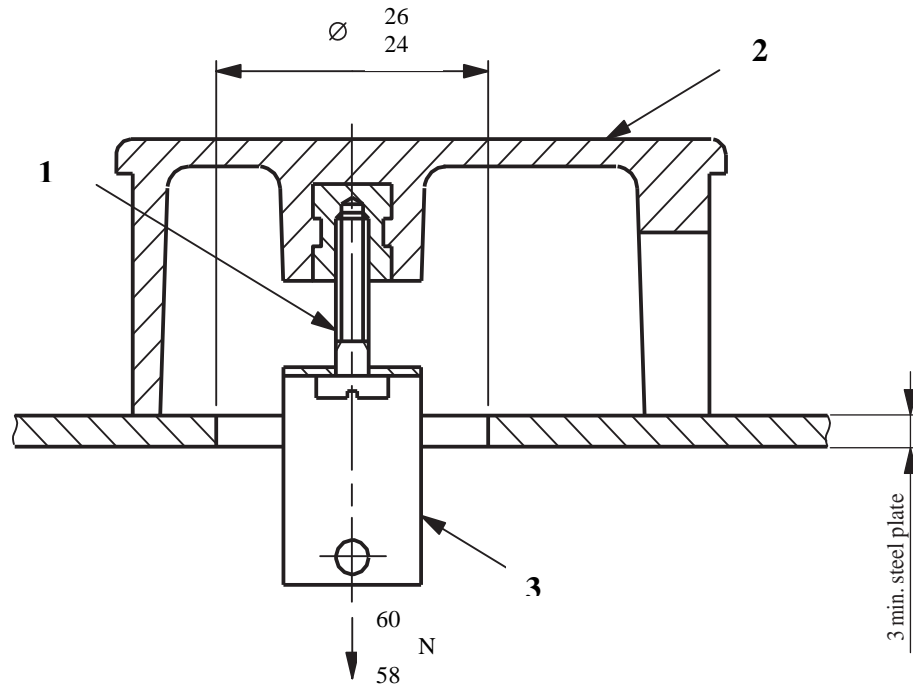
**KEY**

- 1 Cover retaining screw positioned as in service
- 2 Sample plug/adaptor cover supported with cover fixing screw axis vertical
- 3 Light metal stirrup

NOTES: 1 *Dimensions are in millimeters.*

2 *This drawing is not intended to govern design, except as regards the dimensions and specific requirements shown.*

FIGURE 7 - Apparatus for testing plug cover fixing screws (see 12)

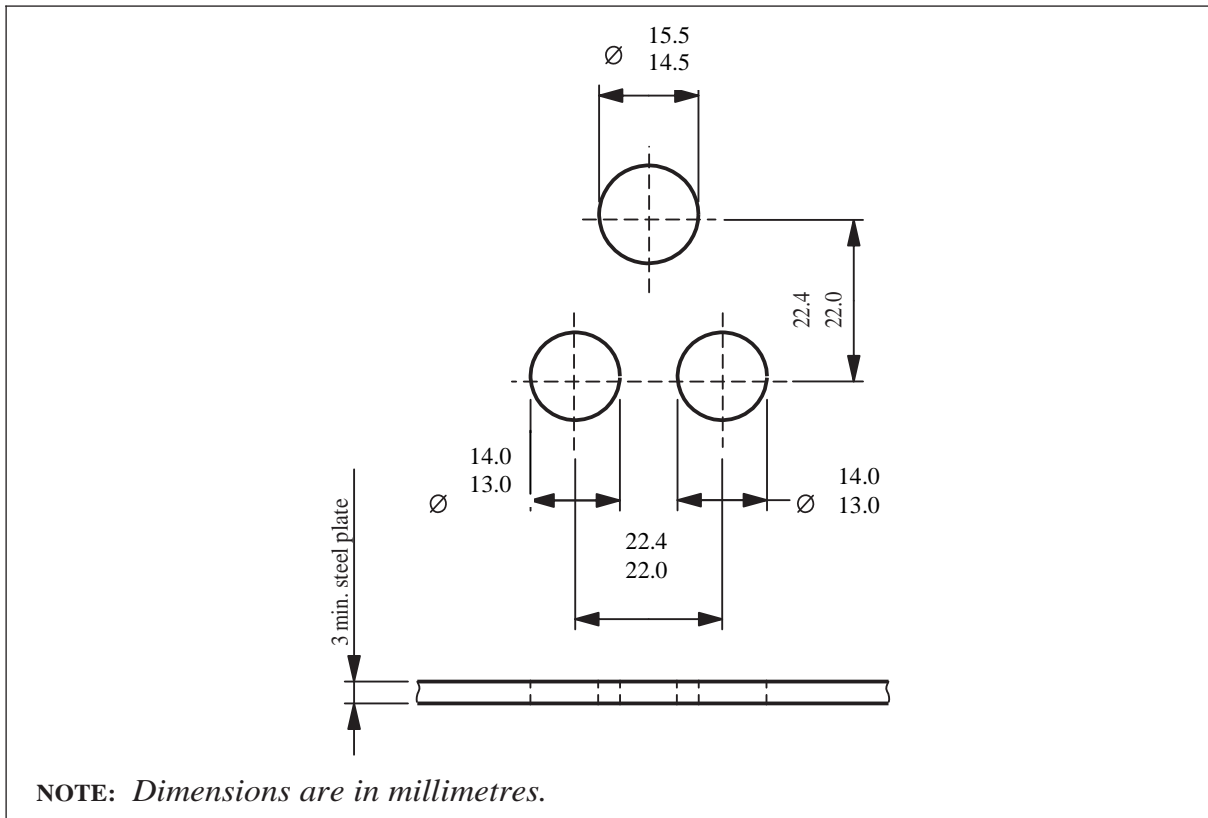

FIGURE 8 - Mounting plate (see 12)

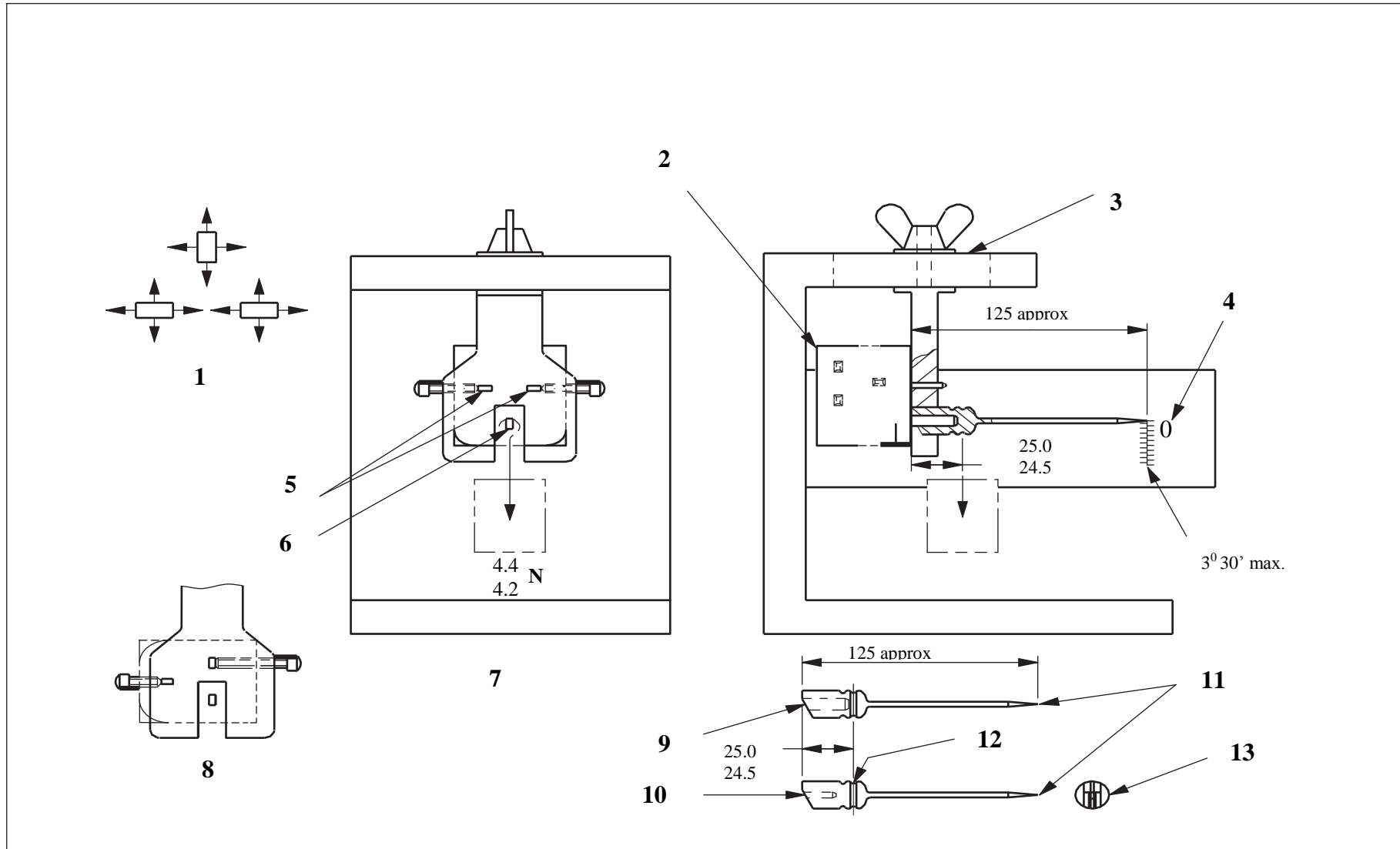

FIGURE 9 – Plug pin deflection test apparatus for resilient adaptors (see 12) (Continued)

Key	
1	Shape of plug mounting block should allow for the direction of pull when measuring deflection of pins as shown in diagram
2	Back of plug should not be supported or come into contact with fixture
3	Mounting block clamped in slot which gives adjustment to allow for various plugs
4	Zero on scale = horizontal axis of pin under test
5	Clamped pins
6	Pin under test for deflection measurement
7	Elevation of fixture shows disposition of plug pins for deflection test on earth pin
8	Diagrams show disposition of plug pins in typical mounting block for deflection test on current-carrying pins
9	Spring fit on to earth pin or ISOD
10	Spring fit on current-carrying pin
11	Indicating point
12	Groove for weight
13	Slot to ensure spring fit
NOTES:	1 <i>Dimensions are in millimeters.</i>
	2 <i>This drawing is not intended to govern design, except as regards the dimensions and specific and requirements shown.</i>
	3 <i>Indicators manufactured from material of negligible weight, such as aluminium</i>

FIGURE 9 – Plug pin deflection test apparatus for resilient adaptors (see 12) (Concluded)

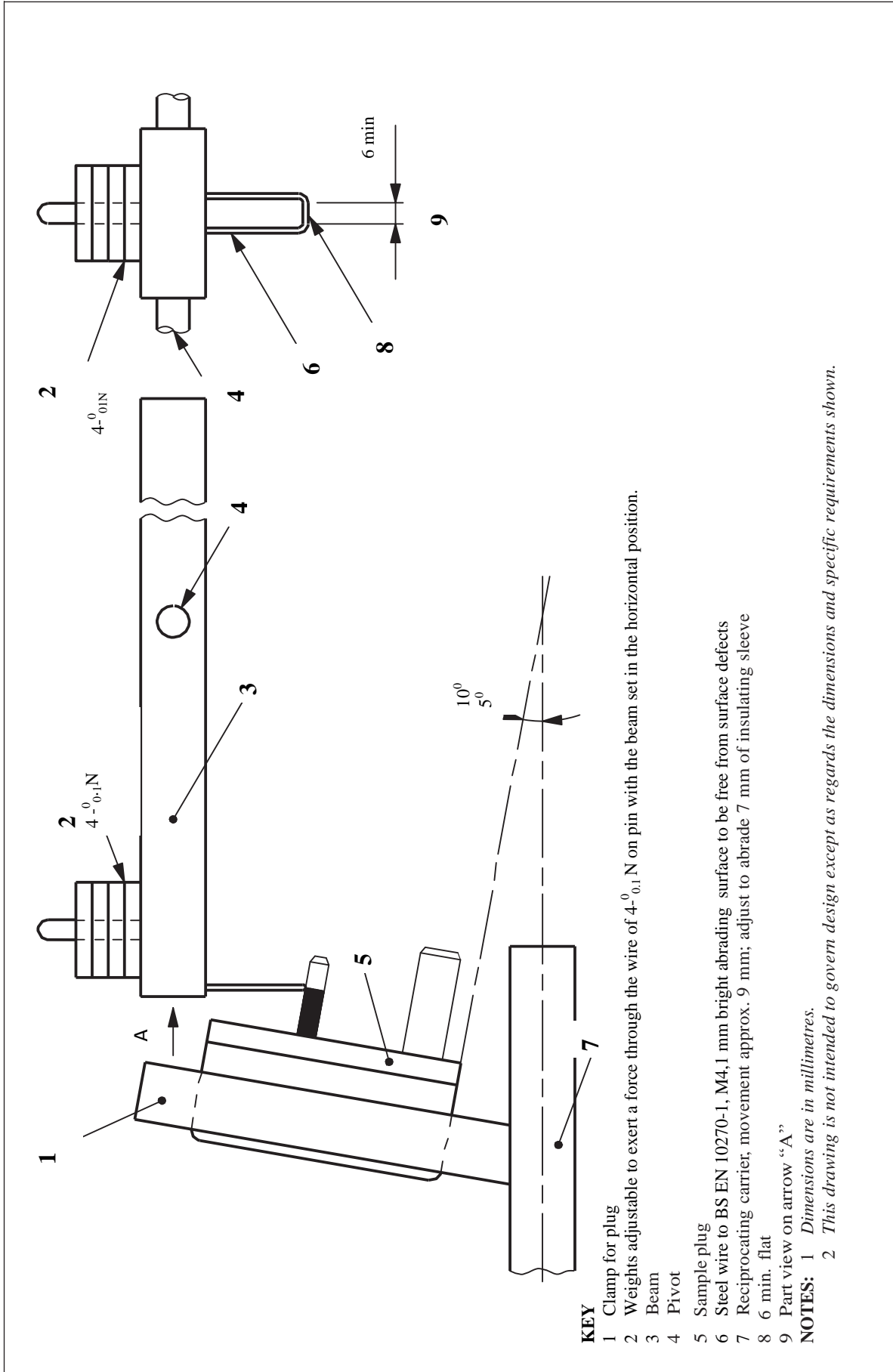

FIGURE 10 - Apparatus for abrasion test insulating sleeves of plug pins (see 12)

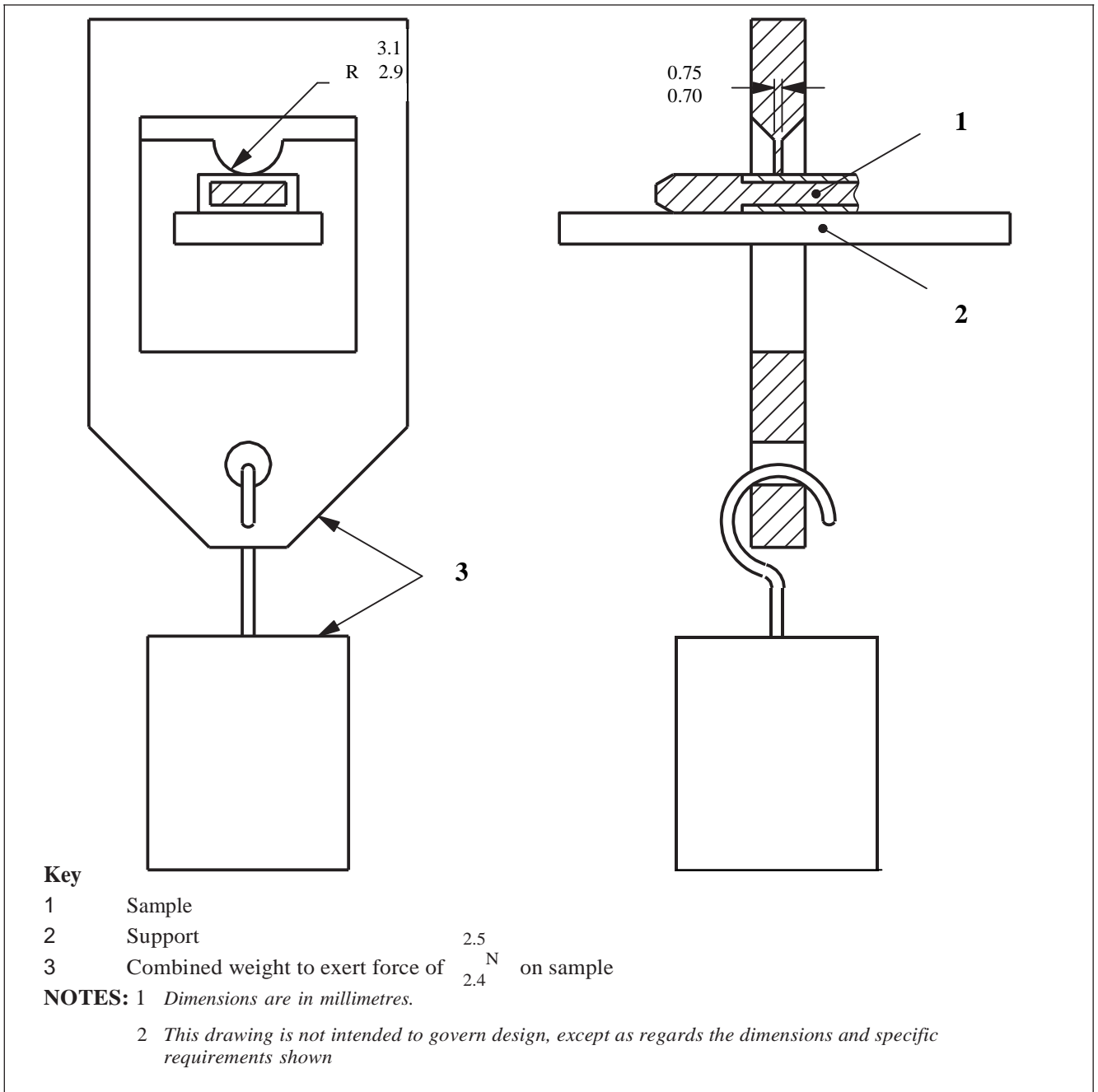

FIGURE 11 - Apparatus for Pressure test at high temperature (see 12)

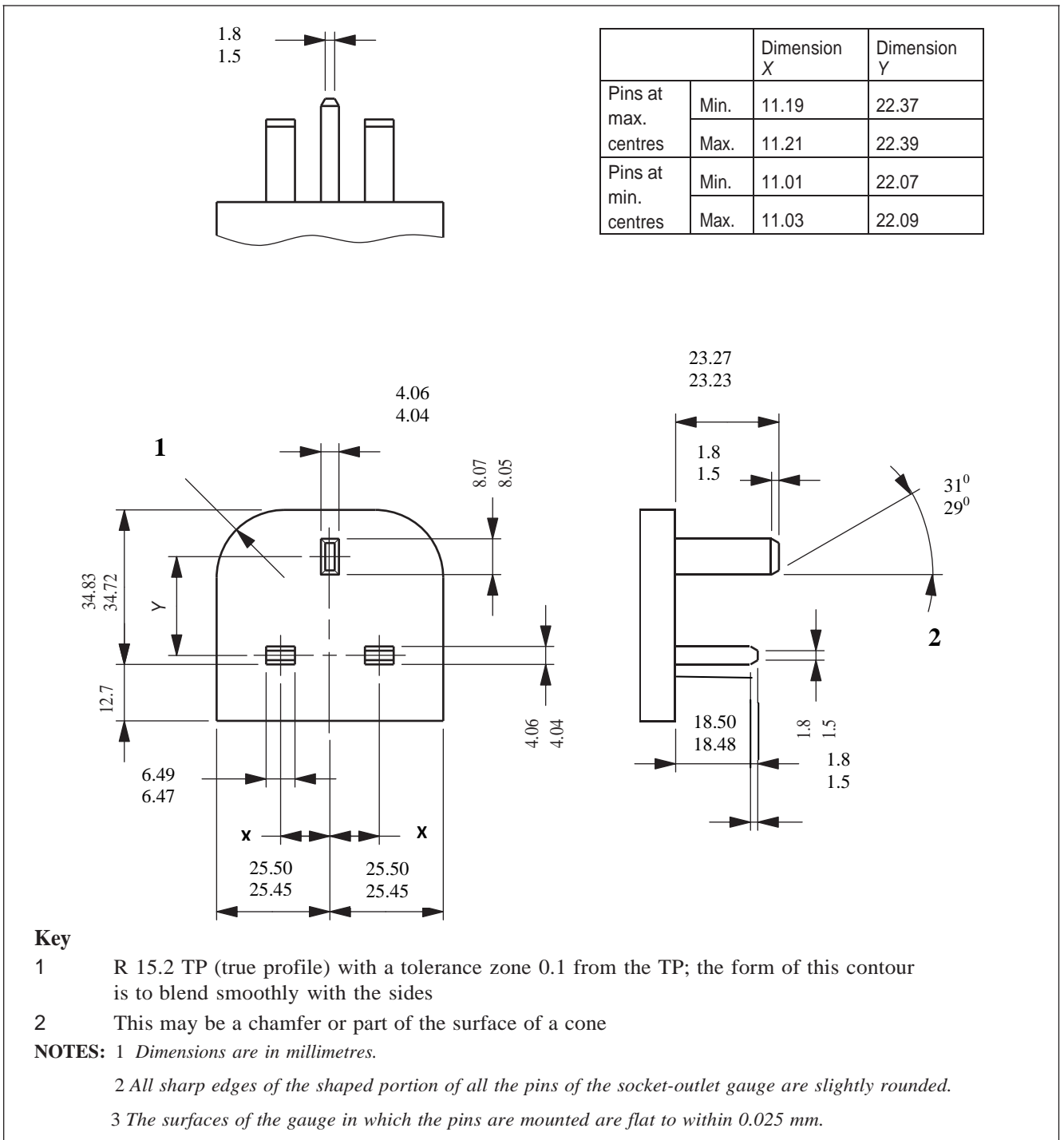
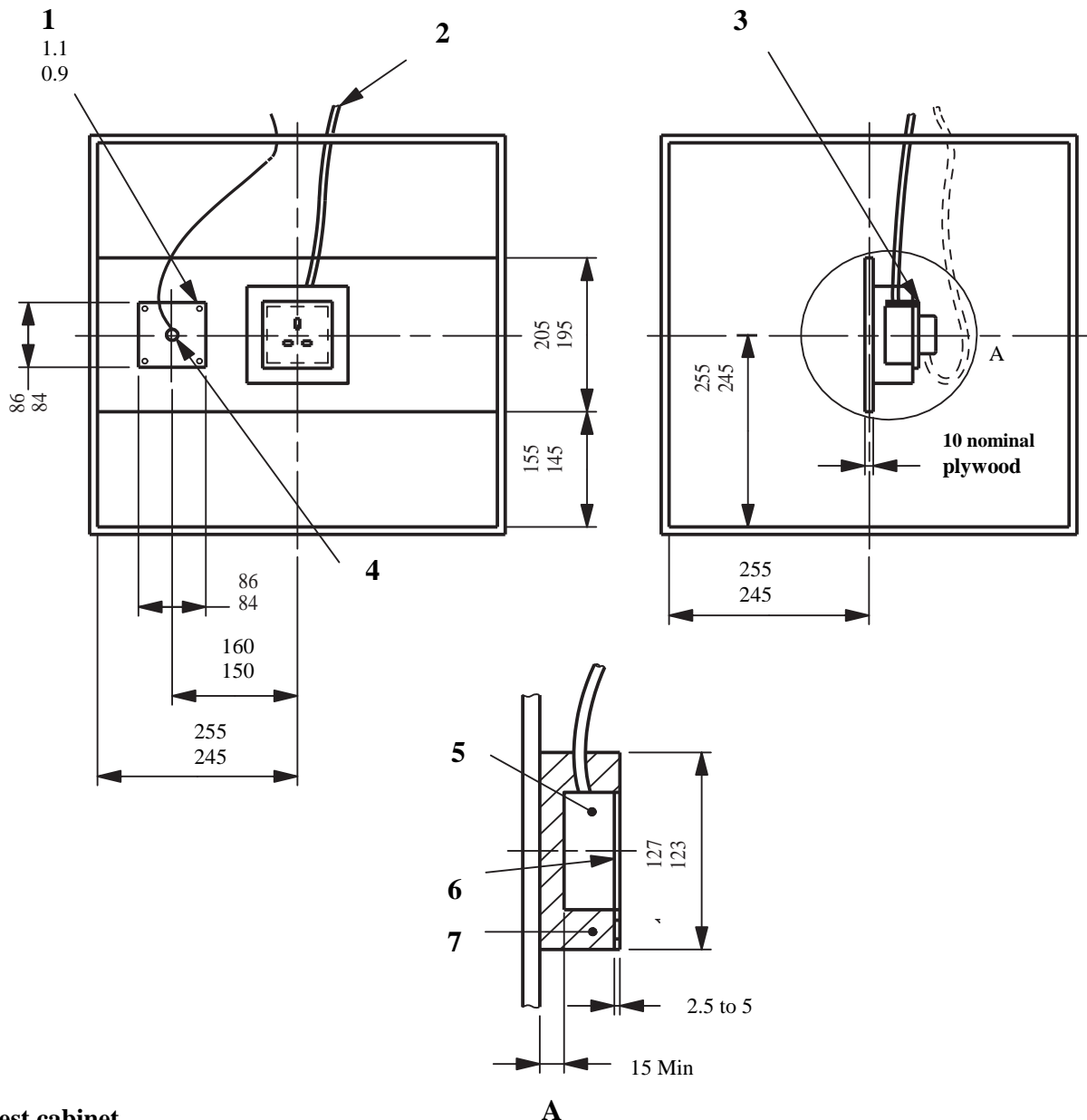

FIGURE 12 – Go gauge for socket- outlet (see 12)



Test cabinet

- Material: 10 mm nominal plywood.
- Finish: Internal. Two coats of matt paint. BS 4800:2011, colour no. 08 C 35.
- Dimensions: Internal. (500 × 500 × 500) mm with a tolerance of ±10 mm for each dimension. One wall to be removable to provide access.
- Location: Minimum clearance from adjacent surfaces, measured horizontally 150 mm on all sides, measured vertically 300 mm above, 500 mm below.

Key

- 1 Brass plate 0.9 mm thick screwed to plywood board
- 2 Cable and thermocouple wire outlet to be sealed
- 3 Plate as Figure 14)
- 4 Thermocouple for reference point temperature
- 5 Mounting box to SLS 1310, Figure 1, 35 mm deep (nominal)
- 6 Front edge recessed as shown
- 7 Wooden mounting block

NOTE: All dimensions are in millimeters.

FIGURE 13 - Test apparatus for temperature rise test (see 15)

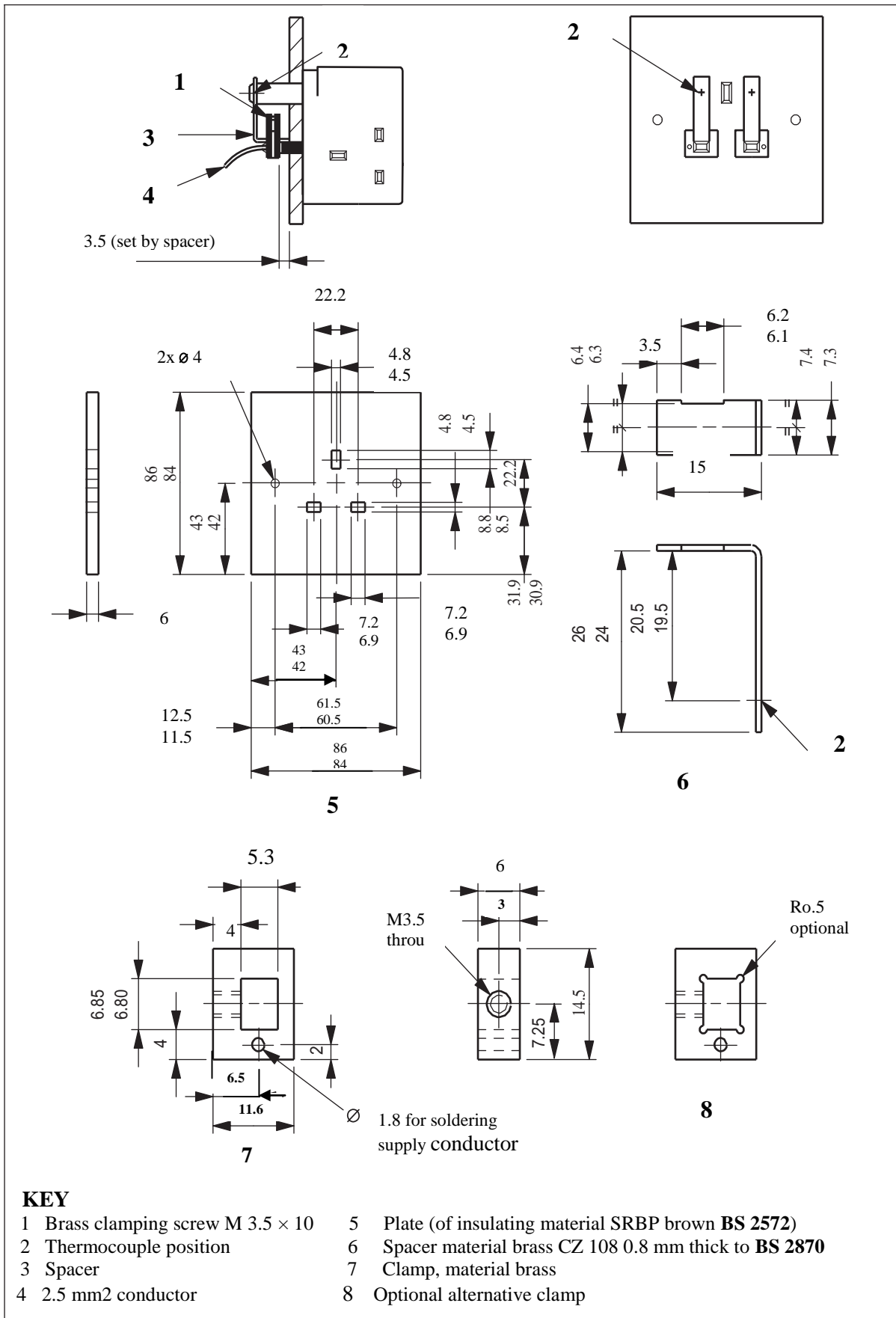

FIGURE 14 – Dummy front plate for temperature rise test (see 15) (Continued)

NOTES: 1 *Dimensions are in millimetres.*

2 *Tolerance ± 0.2 mm except where otherwise shown.*

* The positional tolerance of the three pin apertures shall be proved by the use of gauges in accordance with Figure 12.

FIGURE 14 – Dummy front plate for temperature rise test (see 15) (Concluded)

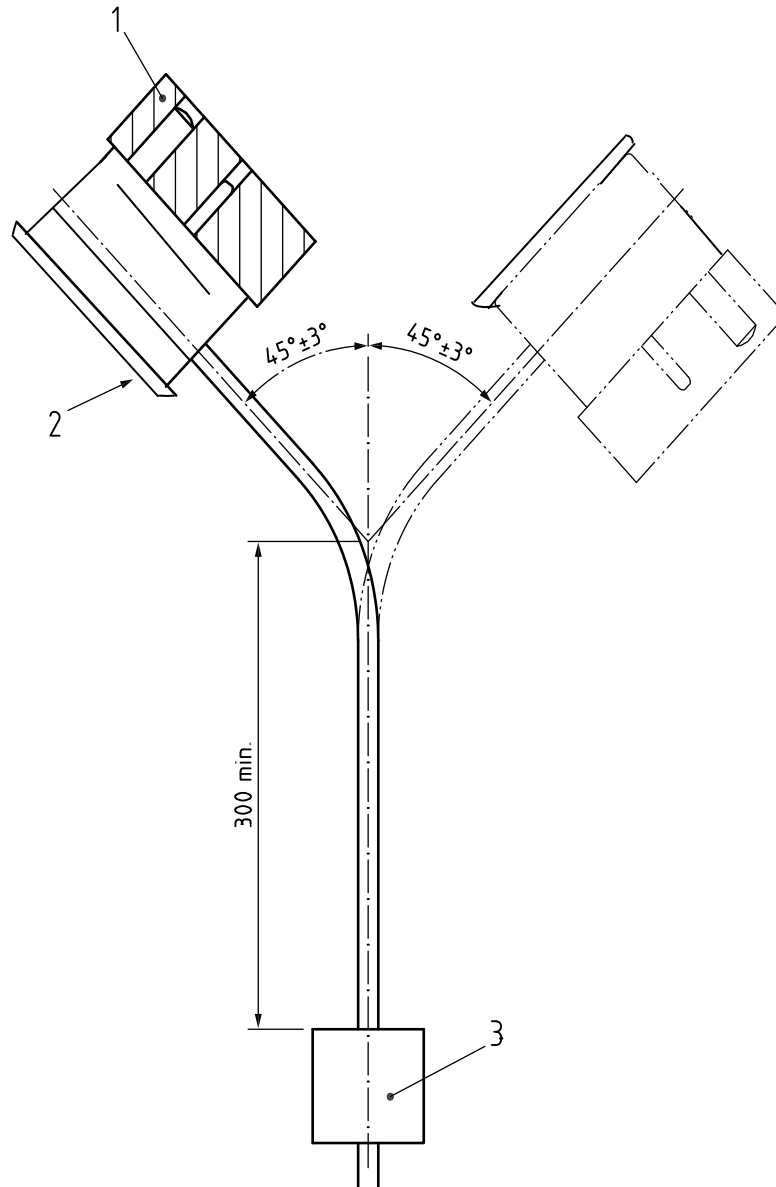

Key

1 Device for fixing sample

2 Samples

3 Mass

NOTES: 1 *Dimensions are in millimetres.*

2 *This drawing is not intended to govern design except as regards the dimensions and specific requirements shown*

FIGURE 15 –Apparatus for flexing test (see 18)

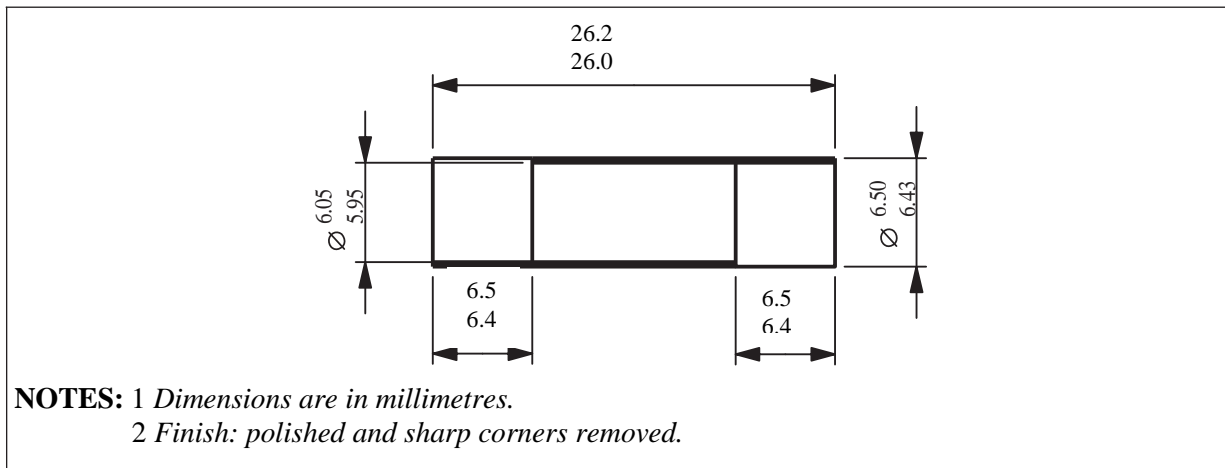

FIGURE 16 – Solid link for test on fuse clips (see 19)

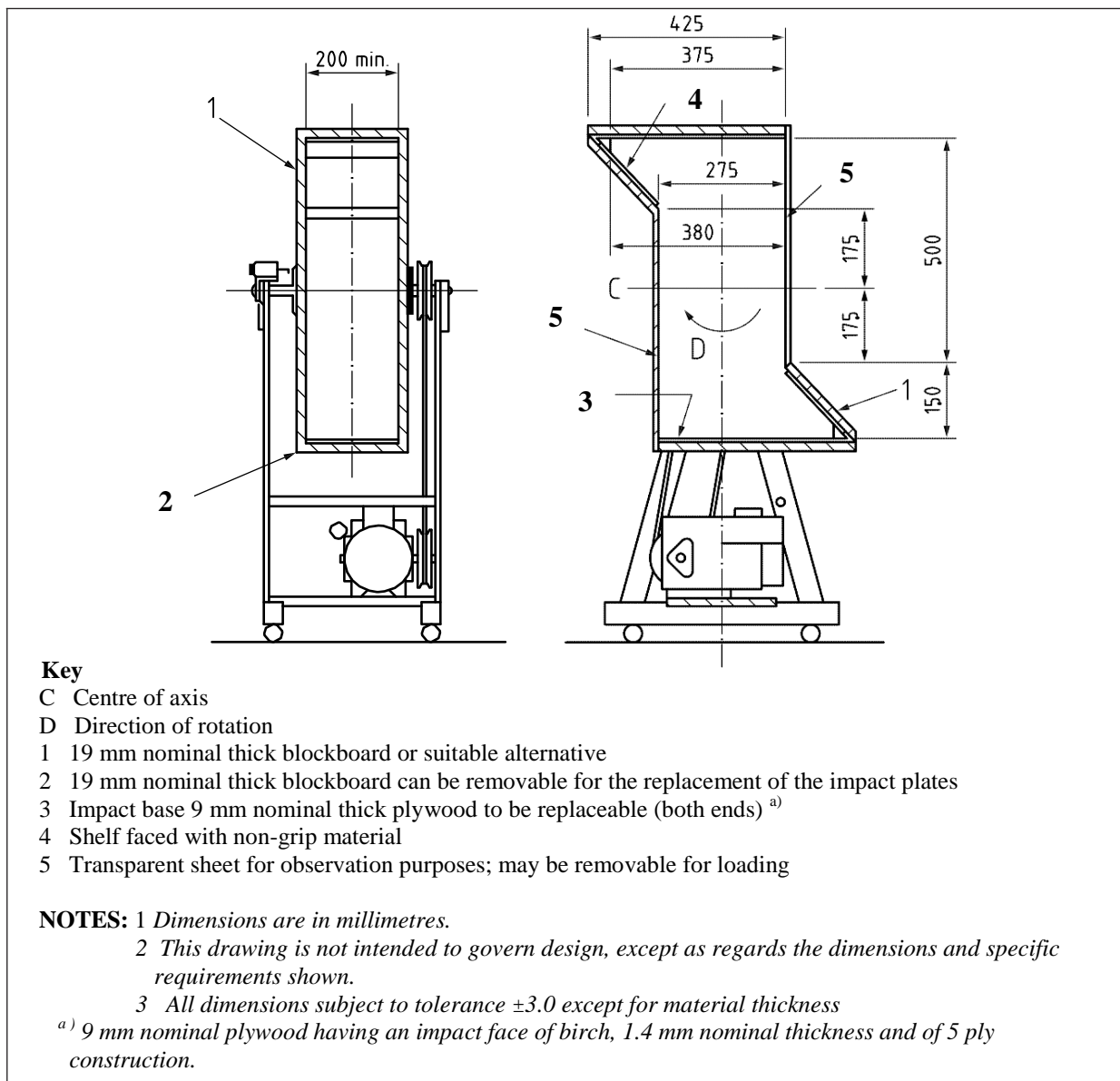

FIGURE 17 – Tumbling barrel (see 19)

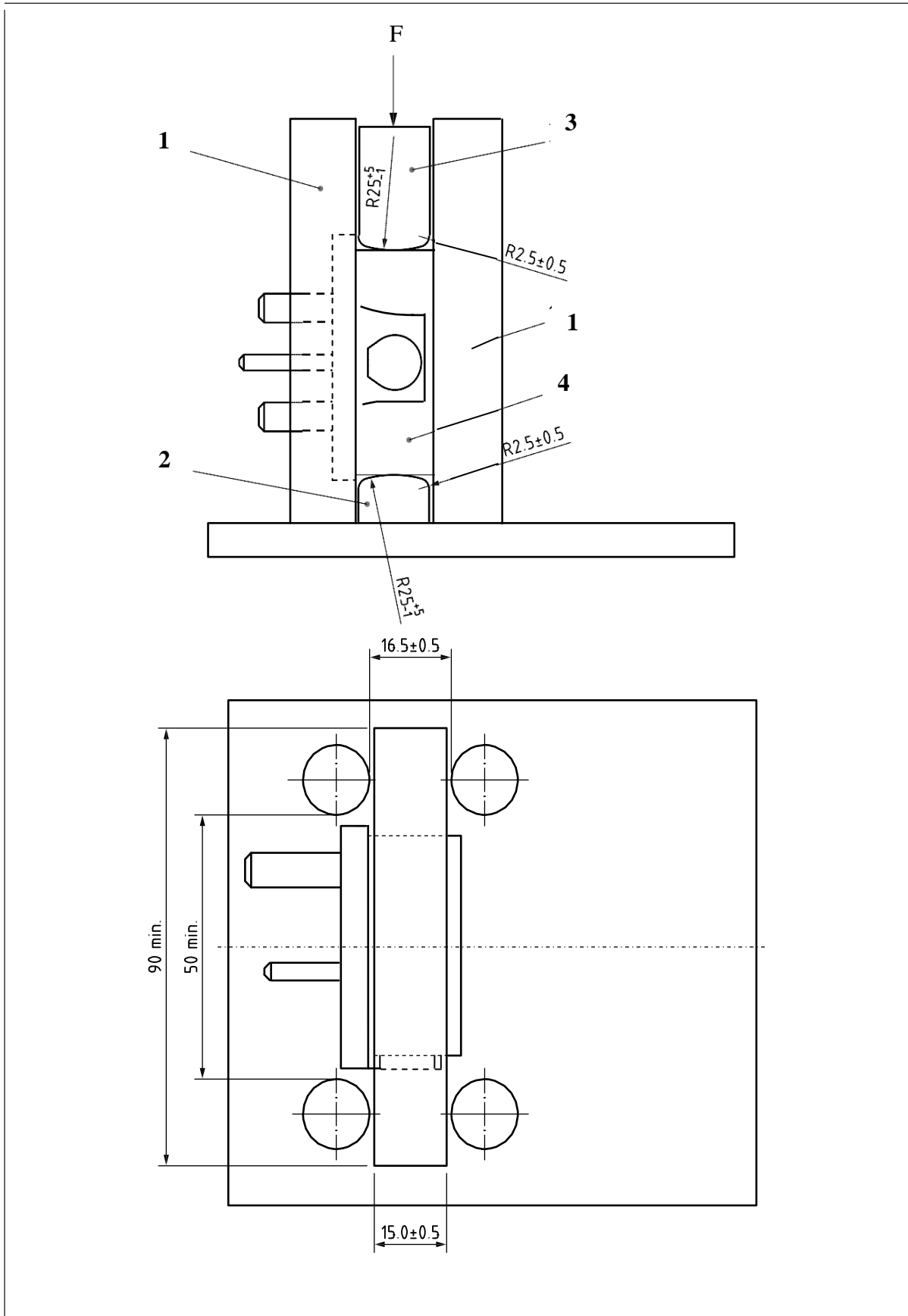

FIGURE 18 - Apparatus for pressure test (see 21) (Continued)

Key

- F Force
- 1 Guide
- 2 Fixed jaw
- 3 Moving jaw
- 4 Sample

NOTES: 1 *Dimensions are in millimetres.*

2 *This drawing is not intended to govern design except as regards the dimensions and specific requirements shown.*

FIGURE 18 - Apparatus for pressure test (see 21) (Concluded)

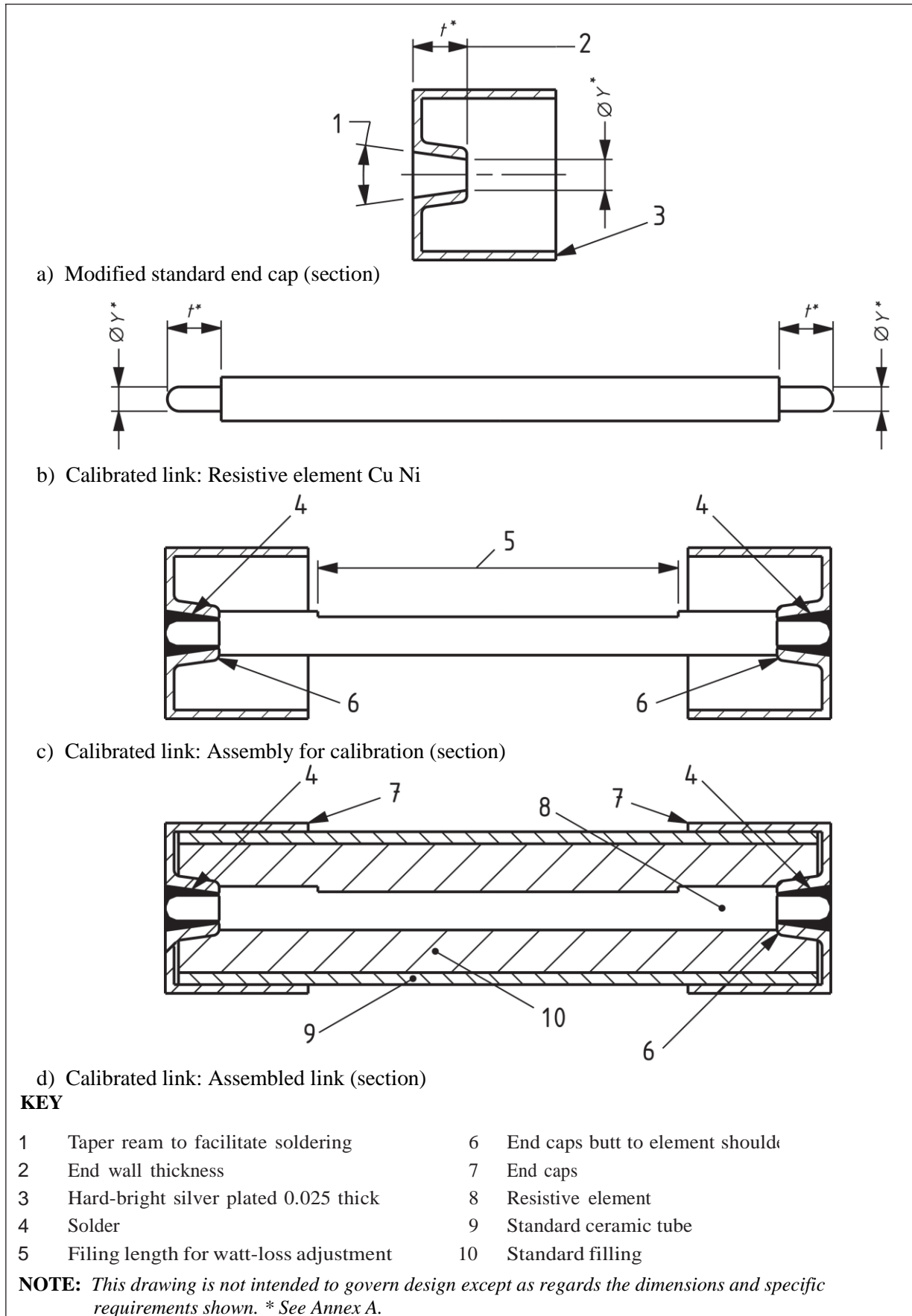

FIGURE 19 - Calibrated link (see A.1)

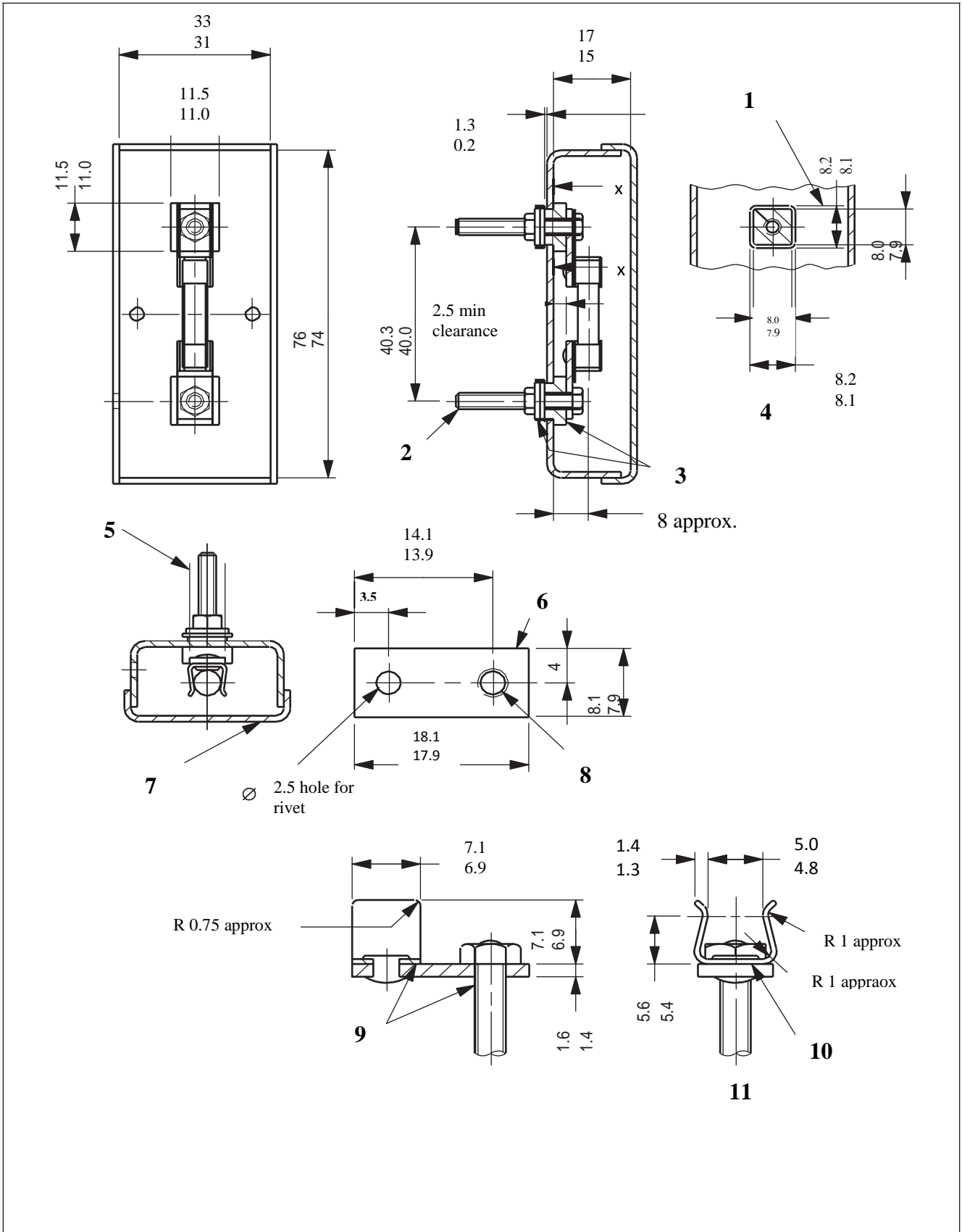

FIGURE 20- Calibration jig for calibrated link (see A.2) (Continued)

Key	
1 Float ^{a)}	7 Cover ^{b) c)}
2 Terminal stem M3 × 25	8 Hole tapped M3 for terminal stem
3 Insulating material	9 Joints between clip, contact plate and terminal stem to be soldered
4 Part section X-X ^{a)}	10 Fuse clip ^{d)}
5 Groove to fit contact plate	11 Contact assembly
6 Contact plate, brass	

^{a)} The end float and clearance between the insulation and the box is to allow the contacts to be self aligning.

^{b)} Box and cover made from 1.25 mm brass sheet, clean natural finish.

^{c)} Cover shall be a push fit on box and shall not be rigidly attached.

^{d)} Fuse clip made from beryllium copper 0.45 mm thick and heat treated (170 HV minimum). Base of clip to be flat; finish, silver plated. Notes/requirements/footnotes

NOTE: *Dimensions are in millimetres.*

FIGURE 20- Calibration jig for calibrated link (see A.2) (Concluded)

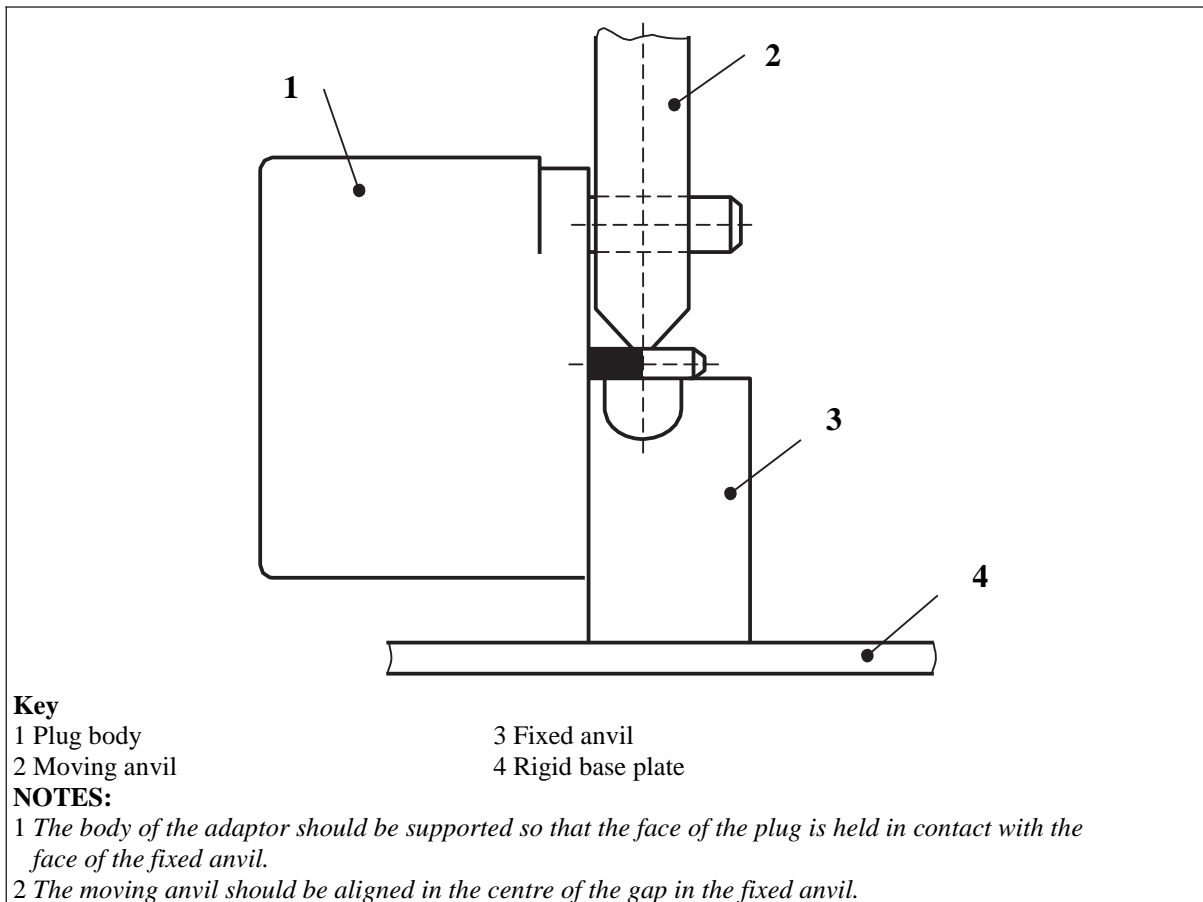

FIGURE 21 - Apparatus for tests on plug pins : A plug pin under test (see 12)

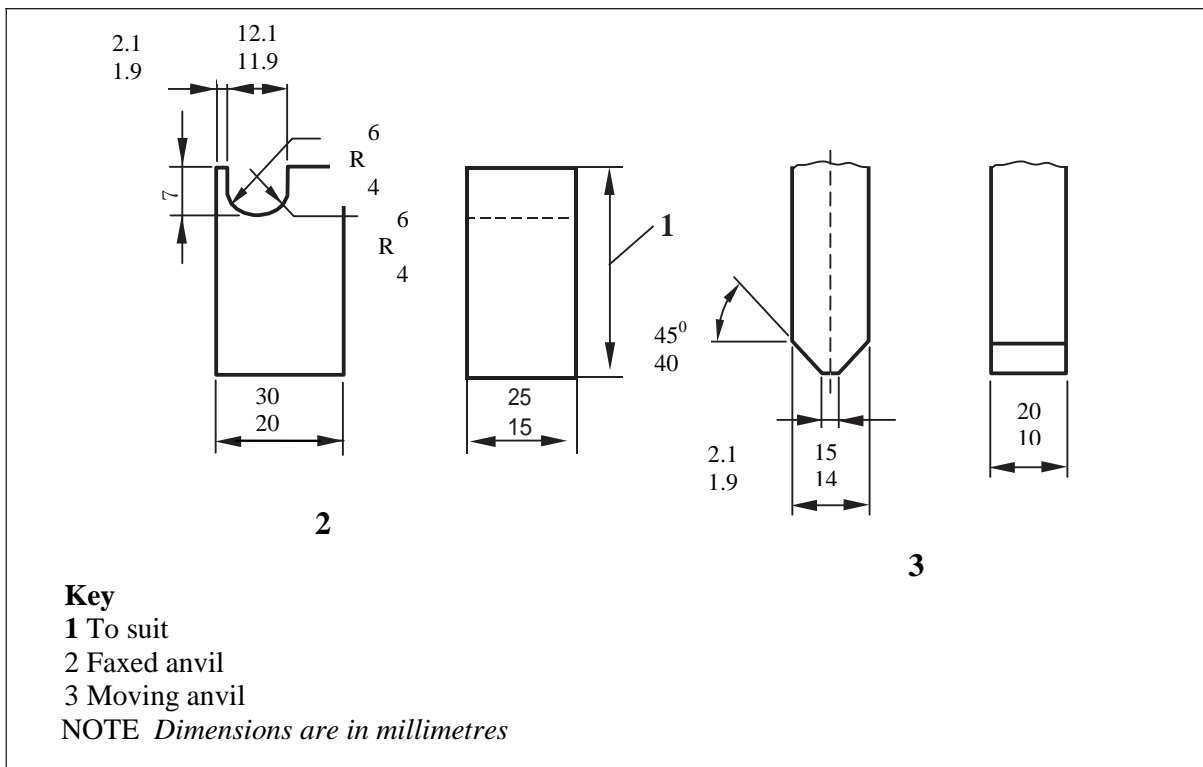

FIGURE 22 - Apparatus for tests on plug pins: Details of anvils (see 12)

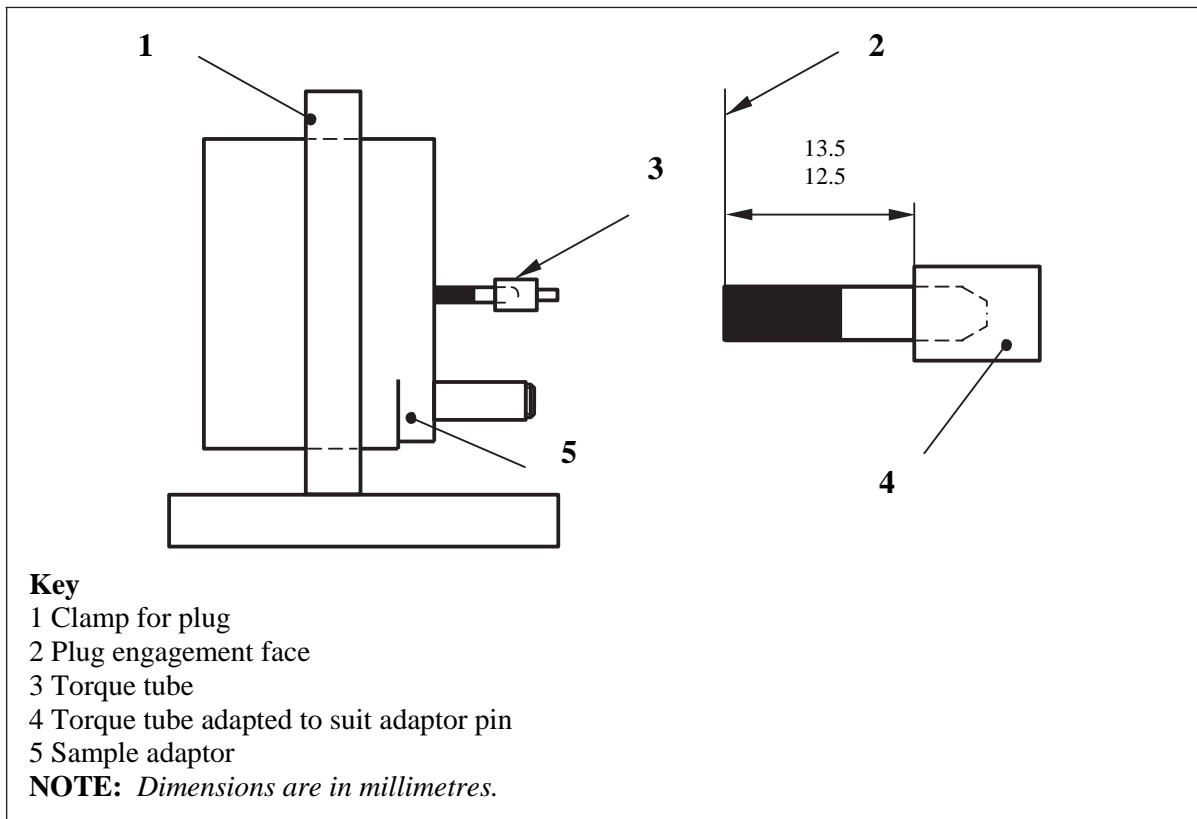

FIGURE 23 – Apparatus for torsion test on pins (see 12)

ANNEX A
(Normative)
THE CONSTRUCTION AND CALIBRATION OF A CALIBRATED LINK

A.1 CONSTRUCTION

The calibrated link (see Figure 19) shall employ the following components used to produce fuses conforming to **SLS 1533**.

- a) Ceramic body (as standard);
- b) filing (as standard);
- c) end caps [modified standard cap as shown in Figure 19a)].

The resistive element shall be of copper nickel wire having a resistivity value between $44 \mu\Omega \text{ cm}$ and $49 \mu\Omega \text{ cm}$. The overall length shall be $25.4^{+0.8}_{-0.4}$ mm and the diameter such as to allow a small reduction in the cross-sectional area to adjust the watts loss to be required value. The ends are turned down so that the distance between the shoulders so formed shall be $25.4^{+0.8}_{-0.4}$ mm less twice the end cap end wall thickness “*t*” (see Figure 19b).

The resistive element shoulders shall be firmly butted to the inside faces of the end caps and soldered using at in silver solder, grade 96S, as specified in **BS 219**. The assembly thus formed (see Figure 19c) shall be checked for watts loss in accordance with **A.2**. Metal shall then be filed carefully from the resistive element over as long a length as is possible and the assembly rechecked until the desired watts loss is achieved.

One end cap shall then be unsoldered, a standard ceramic body fitted, the cavity filled and the end cap resoldered in position making sure the shoulder of the element is butted to the inside of the end cap; the ceramic body shall not interfere with this condition [see Figure 19d)].

The watts loss shall be rechecked in accordance with **A.2** and adjusted if necessary.

The resulting calibrated link shall be marked “NOT A FUSE” on the ceramic body and shall dimensionally be in accordance with **SLS 1533**.

A.2 CALIBRATION

The calibration jig shown in Figure 20 is mounted horizontally approximately 25 mm above a wooden board by means of two ceramic pillars. A fine wire thermocouple is attached to the centre of each fuse contact clip, on the outside of the top edge, in such a way that it does not interfere with the contact area. The thermocouples are taken out of the box in slots cut in one end of the jig base, the width of the slots just being sufficient to accept the diameter of the thermocouples. The connection to the jig base shall be by means of PVC insulated single-core copper cables, $0.3 \text{ m} \pm 0.05 \text{ m}$ in length and 2.5 mm^2 cross-section.

The surroundings shall be free from draughts and the ambient air temperature, measured by a suitable thermometer or thermocouple at a horizontal distance of 1m to

2 m from the standard link shall be in the range of 15 °C to 25 °C. The standard link shall be inserted into the clips provided in the calibration jig and the cover replaced. A current of $13\text{A} \pm 0.1\text{ A}$ is then passed continuously through the calibrated link for $60\text{ min} \pm 5\text{min}$. At the end of this time the temperature measured by the thermocouples are noted, the cover of the jig is then removed and the millivolt drop between the end surfaces of the end caps of the calibrated link is measured whilst it is still carrying the test current.

Alternating current (a.c.) shall be used for the calibration.

The calibration is considered to be correct when the following apply:

- a) the product of the measured millivolt drop multiplied by the test current gives a result of $1_{-0.05}^0\text{ W}$;
- b) the temperature difference between the fuse contact clips does not exceed 2 °C.

ANNEX B
(Normative)

MEASUREMENT OF CLEARANCE AND CREEPAGE DISTANCES

The width X specified in Examples 1 to 11 apply to all examples as a function of the pollution degree as given in Table B.1.

Table B.1 - Minimum values of width

Pollution degree	Minimum values of width X mm
1	0.25
2	1.0
3	1.5

If the associated clearance is less than 3 mm, the minimum groove width may be reduced to one third of this clearance.

The methods of measuring creepage distances and clearances are indicated in the following Examples 1 to 11. These cases do not differentiate between gaps and grooves or between types of insulation.

The following assumptions are made:

- a) any recess is assumed to be bridged with an insulating link having a length equal to the specified width X and being placed in the most unfavourable position.
(see Example 3);
- b) where the distance across a groove is equal to or larger than the specified width X , the creepage distance is measured along the contours of the groove (see Example 2);
- c) creepage distances and clearances measured between parts which can assume different positions in relation to each other, are measured when these parts are in their most unfavourable position.

Explanation for examples 1 to 11

----- clearance

▬ creepage distance

All dimensions are in millimeters.

Example 1

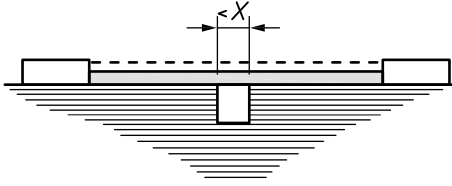

Condition: Path under consideration includes a parallel- or converging sided groove of any depth and with a width less than “X” mm.
Rule: Creepage distance and clearance are measured directly across the groove as shown.

Example 2

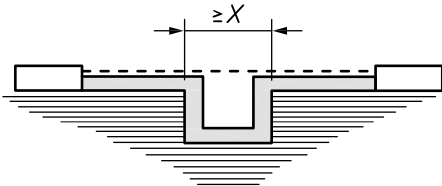

Condition: Path under consideration includes a parallel- sided groove of any depth and with a width equal to or greater than “X” mm.
Rule: Clearance is the “line of sight” distance. Creepage part follows the contour of the groove.

Example 3

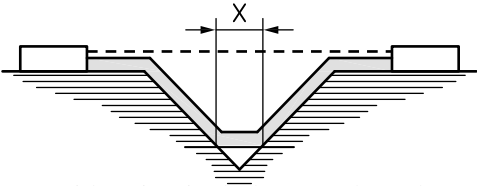

Condition: Path under consideration includes a V-shaped groove with a width greater than “X” mm.
Rule: Clearance is the “line of sight” distance. Creepage path follows the contour of the groove but “short-circuits” the bottom of the groove by an “X” mm link.

Example 4

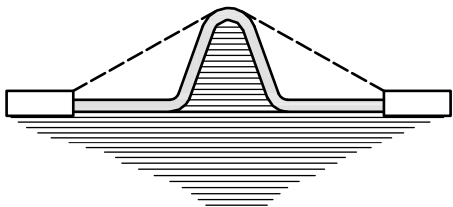

Condition: Path under consideration includes a rib.
Rule: Clearance is the shortest direct air path over the top of the rib. Creepage path follows the contour of the rib.

Example 5

Condition: Path under consideration includes an uncemented joint with grooves less than “X” mm wide on each side.
Rule: Creepage and clearance path is the “line of sight” distance shown.

Example 6

Condition: Path under consideration includes an uncemented joint with grooves equal to or more than “X” mm wide on each side.
Rule: Clearance path is the “line of sight” distance. Creepage follows the contour of the grooves

Example 7

Condition: Path under consideration includes an uncemented joint with groove on one side less than “X” mm wide and the groove on the other side equal to or more than “X” mm wide.
Rule: Clearance and creepage paths are as shown.

Example 8

Condition: Path under consideration includes a barrier with an uncemented joint. The creepage distance through the uncemented joint is less than the creepage distance over the barrier.
Rule: Clearance is the shortest direct air path over the top of the barrier. The creepage path follows the contour of the joint.

Example 9

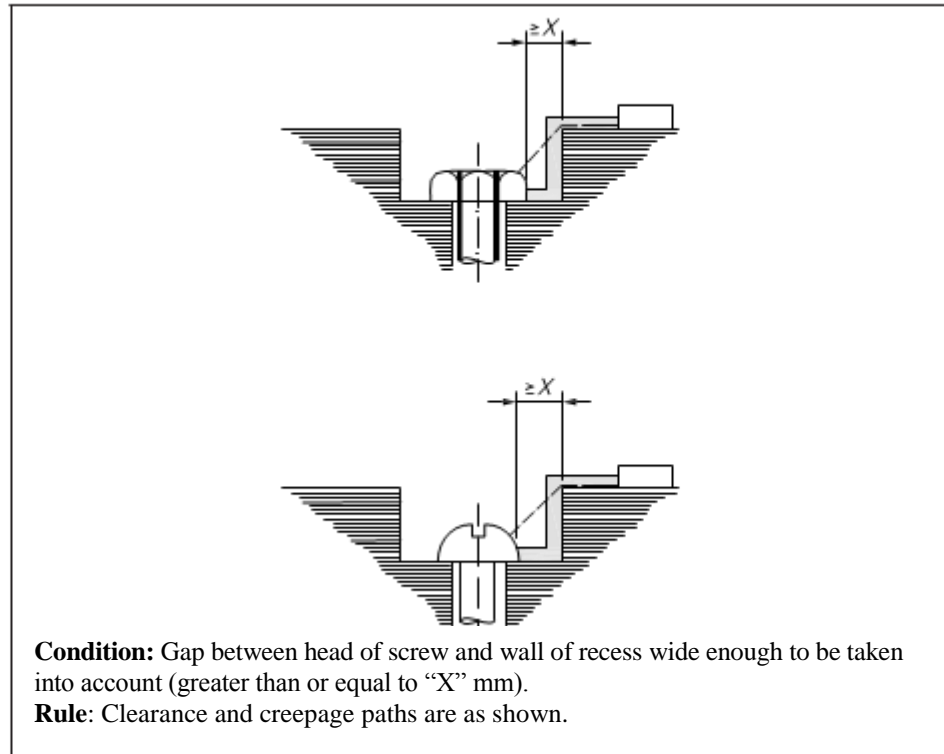

Example 10

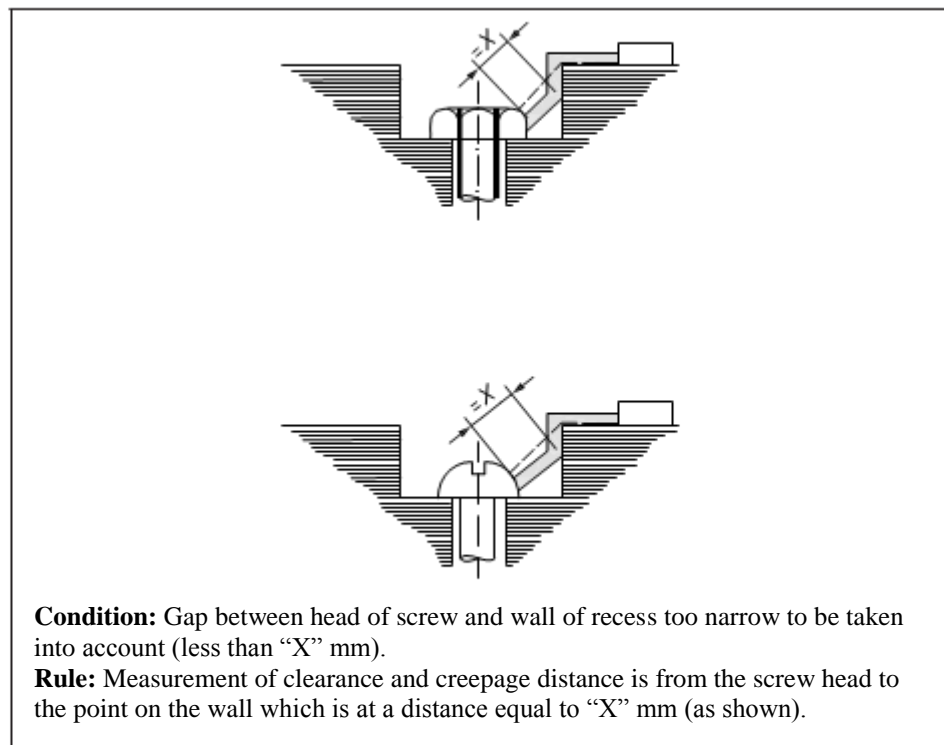

Example 11

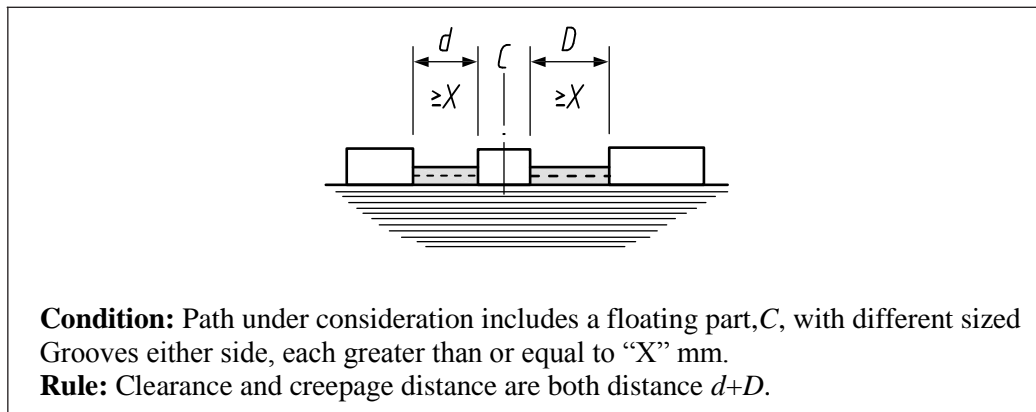

ANNEX C
(Normative)

**DETERMINATION OF THE COMPARATIVE TRACKING INDEX (CTI) AND
 PROOF TRACKING INDEX (PTI)**

The CTI or PTI is determined in accordance with **IEC 60112**. For the purpose of this standard the following applies.

- a) In Clause **5** of **IEC 60112**, Test sample:
 - i) Note **3** and the last paragraph also apply to PTI;
 - ii) If the surface 15 mm x15 mm cannot be obtained because of the small dimensions of the PT system then special samples made with the same manufacturing process may be used.
- b) The test solution “A” described in **7.3** of **IEC 60112** shall be used.
- c) In Clause **8** of **IEC 60112**, procedure, either CTI or PTI is determined.
 - i) CTI is determined in accordance with Clause **11** of **IEC 60112**.
 - ii) The PTI test of Clause **10** of **IEC 60112** is performed on five samples at the voltage referred to in **10.1** of **IEC 60112** based on the appropriate creepage distance, material group, pollution degree conditions and on the rated voltage of this standard declared by the manufacturer.

ANNEX D
(Normative)

**RELATION BETWEEN RATED IMPULSE WITHSTAND VOLTAGE, RATED
VOLTAGE AND OVERVOLTAGE CATEGORY**

Table D.1 – Rated impulse withstand voltage for plugs energized directly from the low-voltage mains

Nominal voltage of the supply system based on SLS 1259 ^{a)} V	Voltage line-to-neutral derived from nominal voltages a.c. or d.c. up to and including V	Rated impulse withstand voltage V		
		Overvoltage Category		
		I	II	III
(1)	(2)	(3)	(4)	(5)
230/400	300	1 500	2 500	4 000

NOTES:

- 1) For more information concerning supply systems see **IEC 60664-1**.
- 2) For more information concerning Overvoltage Category see **IEC 60664-1**.
- 3) Plugs fall into Overvoltage Category III. Parts of plugs where appropriate over voltage reduction is provided fall in to Overvoltage Category I.

^{a)} The/ mark indicates a four-wire three-phase distribution system. The lower value is the voltage line-to-neutral, while the higher value is the voltage line-to-line.

ANNEX E
(Normative)
POLLUTION DEGREE

The micro-environment determines the effect of pollution on the insulation. The macro-environment, however, shall be taken in to account when considering the micro-environment.

Means may be provided to reduce pollution at the insulation under consideration by effective use of enclosures, encapsulation or hermetic sealing. Such means to reduce pollution may not be effective when the PT-system is subject to condensation or if, in normal operation, it generates pollutants itself.

Small clearances can be bridged completely by solid particles, dust and water and therefore minimum clearances are specified where pollution may be present in the micro-environment.

NOTE: *Pollution will become conductive in the presence of humidity. Pollution caused by contaminated water, soot, metal or carbon dust is inherently conductive.*

Degrees of pollution in the micro-environment

For the purpose of evaluating creepage distances and clearances, the following three degrees of pollution in the micro-environment are established.

Pollution degree 1

No pollution or only dry, non-conductive pollution occurs. The pollution has no influence.

Pollution degree 2

Only non-conductive pollution occurs except that occasionally temporary conductivity caused by condensation is to be expected.

Pollution degree 3

Conductive pollution occurs or dry non-conductive pollution occurs which becomes conductive due to condensation which is to be expected.

ANNEX F
(Normative)
IMPULSE VOLTAGE TEST

The purpose of this test is to verify that clearances will withstand specified transient overvoltage. The impulse withstand voltage test shall be carried out with a voltage having a 1.2/50 μ s waveform as specified in **IEC 61180-1** Section **6** and is intended to simulate overvoltage of atmospheric origin. It also covers overvoltage due to switching of low voltage equipment.

The test shall be conducted for a minimum of three impulses of each polarity with an interval of at least 1 s between pulses. There shall be no discharges during the test. Glow discharges without a drop in voltage shall be ignored.

For solid insulation and for clearances not checked by measurement, the impulses withstand voltage shall be applied between:

- a) line and neutral terminals/terminations;
- b) line and neutral terminals/terminations connected together and:
 - i) a sheet of metal foil in contact with the entire accessible external surface;
 - ii) the earthing terminal/termination;
 - iii) any metal part of a cable anchorage;
- c) each switched pole terminal of a switched plug and corresponding plug pin, with the switch contacts open.

NOTES:

- 1) *The output impedance of the impulse generator should be not higher than 500 Ω .*
- 2) *The expression 'discharge' issued to cover the phenomena associated with the failure of insulation under electric stress, which include current flow and a drop in voltage.*

The impulse shall have the following characteristics:

- the waveform 1.2/50 μ s for the no-load voltage with amplitudes equal to the values given in Table F.1;

3) *If the sample is provided with surge suppression, the impulse voltage wave may be chopped but the sample should be in a condition to operate normally again after the test. If the sample is not provided with surge suppression and it withstands the impulse voltage, the wave form will not be noticeably distorted.*

TABLE F.1 - Test voltages for verifying clearances at sea level

Rated impulse withstand voltage kV	Impulse test voltage at sea level kV
0.33	0.35
0.5	0.55
0.8	0.91
1.5	1.75
2.5	2.95
4.0	4.8
6.0	7.3

NOTES:

1) *When testing clearances, associated solid insulation will be subjected to the test voltage. As the impulse test voltage of Table F.1 is increased with respect to the rated impulse withstand voltage, solid insulation will have to be designed accordingly. These results in an increased impulse withstand capability of the solid insulation.*

2) *The test may be made with the pressure adjusted to the value corresponding to the altitude of 2 000 m (80 kPa) and 20 °C with the test voltage corresponding to the rated impulse withstand voltage. In this case, solid insulation will not be subjected to the same withstand requirements as when testing at sea level.*

3) *Explanations concerning the influencing factors (air pressure, altitude, temperature humidity) with respect to electric strength of clearances are given in IEC 60664-1.*

ANNEX G
(Normative)
REQUIREMENTS FOR INCORPORATED ELECTRONIC COMPONENTS

G.1 General

Incorporated electronic components shall conform to their relevant standard(s)

NOTE: *Conformity with a standard for the relevant component does not necessarily ensure conformity with this standard.*

G.2 Electromagnetic compatibility (EMC) requirements

Plugs incorporating electronic circuits, apart from inherently benign components, shall conform to the immunity and emission requirements of the relevant product or generic **IEC 61000** standard series. In particular:

- **IEC 61000-6-1** and
- **IEC 61000-6-3.**

NOTE: *Inherently benign components do not normally generate electromagnetic disturbances. Examples of inherently benign components are LED indicators, diodes, resistors, varistors, capacitors, surge suppressors, inductors. This list is not exhaustive.*

No additional EMC immunity or emission tests are required if the following conditions are fulfilled.

- a) the incorporated devices and components conform to the requirements for EMC as required by the relevant product or generic EMC standard.
- b) the internal installation and wiring is carried out in accordance with the devices and component manufacturer's instructions (arrangement with regard to mutual influences, cable, screening, earthing, etc.).

In all other cases the EMC requirements are to be verified by tests, in particular as per **IEC 61000-6-1** and **IEC 61000-6-3.**

G.3 Surge protective devices

G.3.1 General

Surge protective devices incorporated in **SLS 734 Part 1** plugs shall conform to the requirements in **G.3.2.**

NOTES:

1) *The use of SPDs, variously known as voltage dependant resistors (VDRs), gas discharge tubes, avalanche breakdown diodes and similar devices, might have particular applications*

and restrictions in their use in many safety standards. Restrictions are applied where the disconnection of earth is possible as a single fault condition (applicable for example, to domestic pluggable equipment).

The slow deterioration of surge protection devices with time might result in an increase in leakage current. This can cause a permanent and continuously increasing temperature stress, which can cause the component to burn or burst, and thus SPDs/VDRs are regarded as potential safety hazards.

2) *This annex does not cover comprehensive type testing which is specified in the IEC 61643 series.*

G.3.2 Requirements

The following types of SPD of the appropriate category shall be considered acceptable:

- metal oxide varistors conforming to **IEC 61643-331**;
- gas discharge tubes conformity to **IEC 61643-321**;
- avalanche breakdown diodes conforming to **IEC 61643-311**.

VDRs conforming to **IEC 61051-2** and having the following characteristics shall be considered acceptable:

a) Preferred climatic categories:

Lower category temperature -10 °C

Upper category temperature +85 °C

Duration of damp heat, steady state test: 21 days

b) Maximum continuous voltage:

The maximum continuous a.c voltage shall be at least 315 V.

c) Pulse current (**IEC 61051-2**, Table 1, Group 1)

Combination pulse of 6 kV/3 kA of alternating polarity are used, having a pulse shape of 1.2/50 µs for voltage and 8/20 µs for current.

In addition to the performance requirements of **IEC 61051-2**, Table 1 Group 1, the clamping voltage after the test shall not have change by more than 10 per cent, when measured with the manufacturer's specified current.

G.3.3 Conformity

Conformity to G.3.2 shall be checked by inspection of components conformity evidence.

G.3.4 Incorporation of VDRs in plugs

A circuit interrupting devices having adequate breaking capacity shall be connected in series

with the VDR to provide protection against:

- a) temporary over voltages above the maximum continuous voltage;
- b) thermal overload due to leakage current within the VDR;
- c) burning and bursting of the VDR in the event of a short-circuit fault;

The following methods of VDR incorporation are permitted:

- i) Between L and N

A VDR is permitted between line and protective earth provided it is protected by the **SLS 1533** fuse in the plug.

- ii) Between L and E

A VDR is permitted between line and protective earth provided it is protected by the **SLS 1533** fuse in the plug and is connected in series with a spark gap/gas tube meeting the requirements for basic insulation.

G.3.5 *Conformity*

Conformity to **G.3.4** shall be checked by inspection.

G.4 **Electronic switches**

G.4.1 *General*

Electronic switches incorporated in plugs shall conform to **IEC 60669-2-1**.

G.4.2 *Conformity*

Conformity to **G.4.1** shall be checked by inspection of conformity evidence or by test.

ANNEX H
(Informative)
RECOMMENDATIONS FOR PRODUCTS THAT INCORPORATE
SLS 734 PLUG PINS

TABLE H.1 –List of Clauses

Test carried out to	SLS 734 Part 3
Turning moment test	13.10
Test carried out to:	SLS 734 Part 1
Clause 12 : Construction of plugs	12.1,12.2,12.3,12.9,12.11,12.12,12.13,12.16 & 12.17 only
Clause 12.9.5 (for ISODs and nickel plated pins) Construction of plugs (wear to socket-outlets)	12.9.5, 12.9.5.1 & 12.9.5.2
Clause 21 (for ISODs) Resistance to heat	21.2 only
Clause 22 (for ISODs) Resistance to abnormal heat and fire	22.2 only

ANNEX I
(Informative)

DIMENSIONS FOR PLUG PROFILES

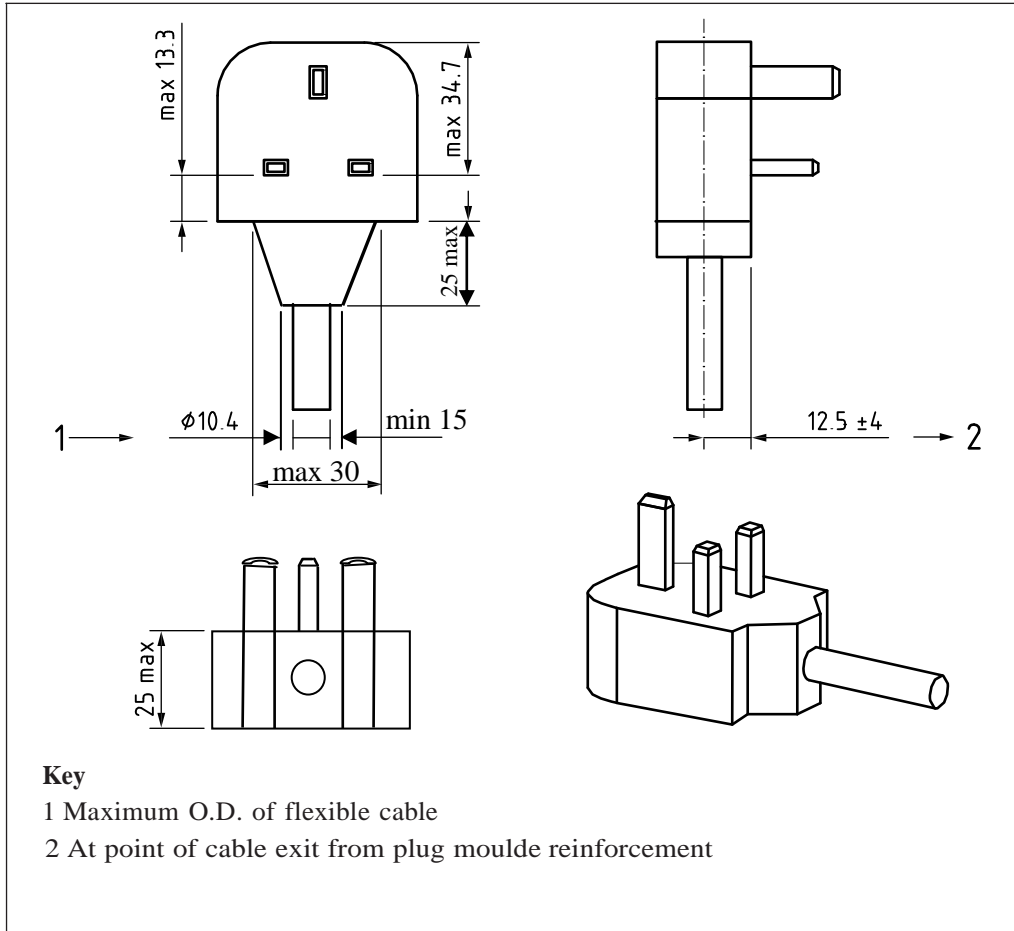

FIGURE I.1 - Normal plug profile

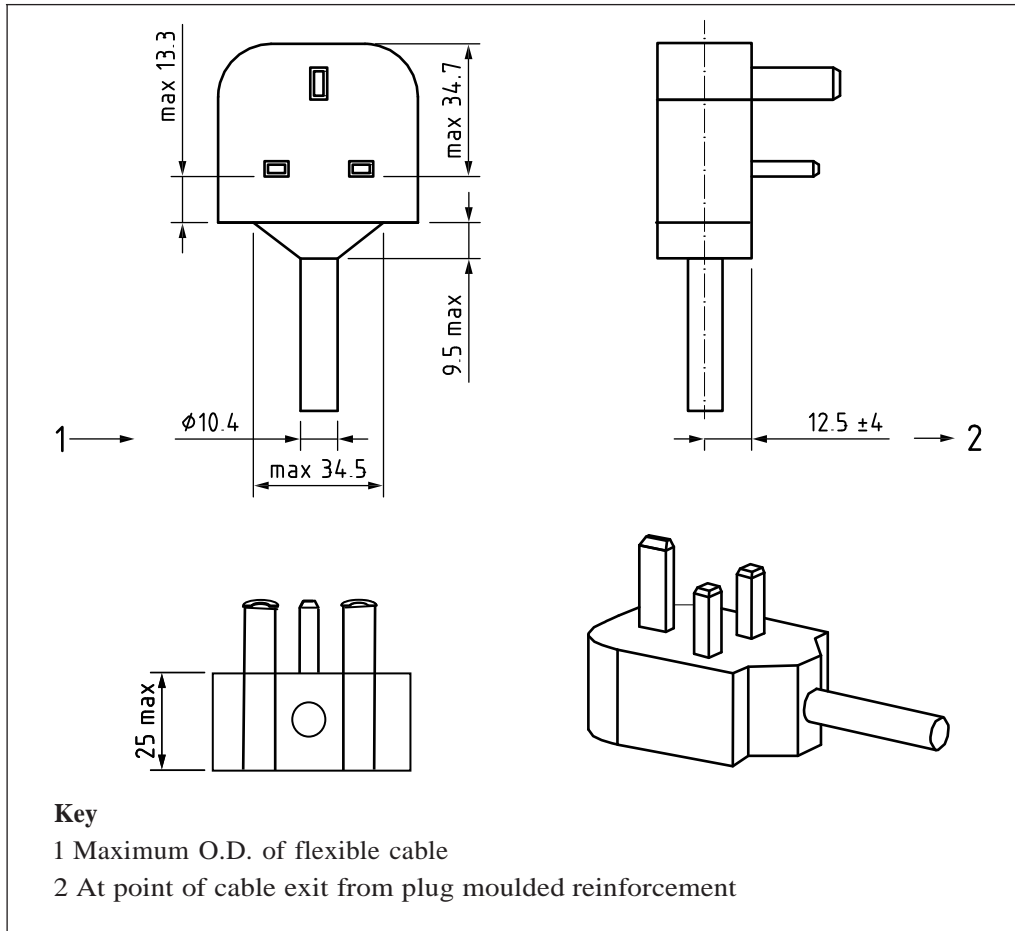

FIGURE I.2- Compact plug profile

Amendment No. 1 Approved on 2019-05-08 to SLS 734: Part 1: 2017**SRI LANKA STANDARD SPECIFICATION FOR 13 A PLUGS, SOCKET-OUTLETS, ADAPTORS AND CONNECTION UNITS PART 1: SPECIFICATION FOR REWIRABLE AND NON-REWIRABLE 13A FUSED PLUGS (Second Revision)**

1) Replace the existing Table 1 with the following Table including new Note 3)

TABLE 1 - Schedule of tests

Sequence	Sample	Test	Clause number
(1)	(2)	(3)	(4)
1	3	Inspection, measurement, gauging and manipulation	5, 6, 7, 11.1, 9.1, 9.2, 9.4, 12.1, 12.2, 12.3, 12.4, 12.5, 12.9, (12.9.1, 12.9.2, 12.9.3 and 12.9.6 only), 12.13, 12.14, 12.15, 12.16, 12.19** 18.2, 18.3, 18.4, 18.6,8 (except Annex C) 20
2	3	General	5, 9.3, 18.1, 12.12, 12.17.2, 12.17.3, 12.17.2
3	3		5, 13.2, 12.8, 18.5, 12.17.4
4	3		5, 13.1, 14.1, 15, 16, 12.18.1, 17, 19, 12.7, 10.1, 11.12, 12.10, 12.6, 12.11
5	3*		5, 12.9.4.1 or 12.9.4.2
6	3		5, 13.1, 20.1
7	3	Additional tests for rewirable plugs with clamp type (screwless) terminals	5, 11.10, 11.11
8a	9	Additional tests for plugs with nickel plated brass pins, non-solid pins and/or ISODs	5, 12.9.5
8b	3	Additional tests for plugs fitted with ISOD	5, 12.9.4.3
9	3	Materials	5, 21
10	3		5, 22.2, 8.2 (Annex C only)
11	3		5, 23
12 ^{A)}	3	Positive break (switched plugs)	5,12.18.2
13	3	Overloads	5, 13.1, 25
14	3	Cyclic loading (plugs for EV)	5, 26

^{A)} An additional new set of three samples prepared with the contacts closed is supplied by the manufacturer for this test.

AMD 518

NOTES

- 1) *The order of tests given in sequence 1 is preferred but not mandatory except where required within the text of the appropriate clause.*
- 2) **denotes that an additional three samples will be required for plugs with non-solid pins.*
- 3) ***denotes that additional samples may be required for plugs incorporating electronic components*

2) **Clause 12.19**

Add new clause as 12.19, immediately after clause 12.18.3 as follows :

12.19 Electronic components incorporated in socket outlets shall conform to Annex G

12.19.1 Conformity shall be checked by inspection of component conformity evidence and the tests of Annex G.

3) **Clause G.3.2 of Annex G**

The first paragraph of clause **G.3.2** of Annex G shall be corrected as follows:

G.3.2 Requirements

The following types of SPD of the appropriate category shall be considered acceptable:

- metal oxide varistors conforming to **IEC 61643-331**;
- gas discharge tubes conforming to **IEC 61643-311**;
- avalanche breakdown diodes conforming to **IEC 61643-321**.

SLS CERTIFICATION MARK

The Sri Lanka Standards Institution is the owner of the registered certification mark shown below. Beneath the mark, the number of the Sri Lanka Standard relevant to the product is indicated. This mark may be used only by those who have obtained permits under the SLS certification marks scheme. The presence of this mark on or in relation to a product conveys the assurance that they have been produced to comply with the requirements of the relevant Sri Lanka Standard under a well designed system of quality control inspection and testing operated by the manufacturer and supervised by the SLSI which includes surveillance inspection of the factory, testing of both factory and market samples.

Further particulars of the terms and conditions of the permit may be obtained from the Sri Lanka Standards Institution, 17, Victoria Place, Elvitigala Mawatha, Colombo 08.



SRI LANKA STANDARDS INSTITUTION

The Sri Lanka Standards Institution (SLSI) is the National Standards Organization of Sri Lanka established under the Sri Lanka Standards Institution Act No. 6 of 1984 which repealed and replaced the Bureau of Ceylon Standards Act No. 38 of 1964. The Institution functions under the Ministry of Science, Technology and Research.

The Principal objects of the Institution as set out in the Act are to prepare standards and promote their adoption, to provide facilities for examination and testing of products, to operate a Certification Marks Scheme, to certify the quality of products meant for local consumption or exports and to promote Standardization and quality control by educational, consultancy and research and research activity.

The Institution is financed by Government grants, and by the income from the sale of its publications and other services offered for Industry and Business Sector. Financial and Administrative control is vested in a Council appointed in accordance with the provisions of the Act.

The development and formulation of National Standards is carried out by Technical Experts and representatives of other interest groups, assisted by the permanent officers of the Institution. These Technical Committees are appointed under the purview of the Sectoral Committees which in return are appointed by the Council. The Sectoral Committees give the final Technical approval for the Draft National Standards prior to the approval by the Council of the SLSI.

All members of the Technical and Sectoral Committees render their services in an honorary capacity. In this process the Institution Endeavours to ensure adequate representation of all view points.

In the International field the Institution represents Sri Lanka in the International Organization for Standardization (ISO), and participates in such fields of Standardization as are of special interest to Sri Lanka.